

Operator's Manual

Transfer Switch Model GTEC 63 to 1250 Amps

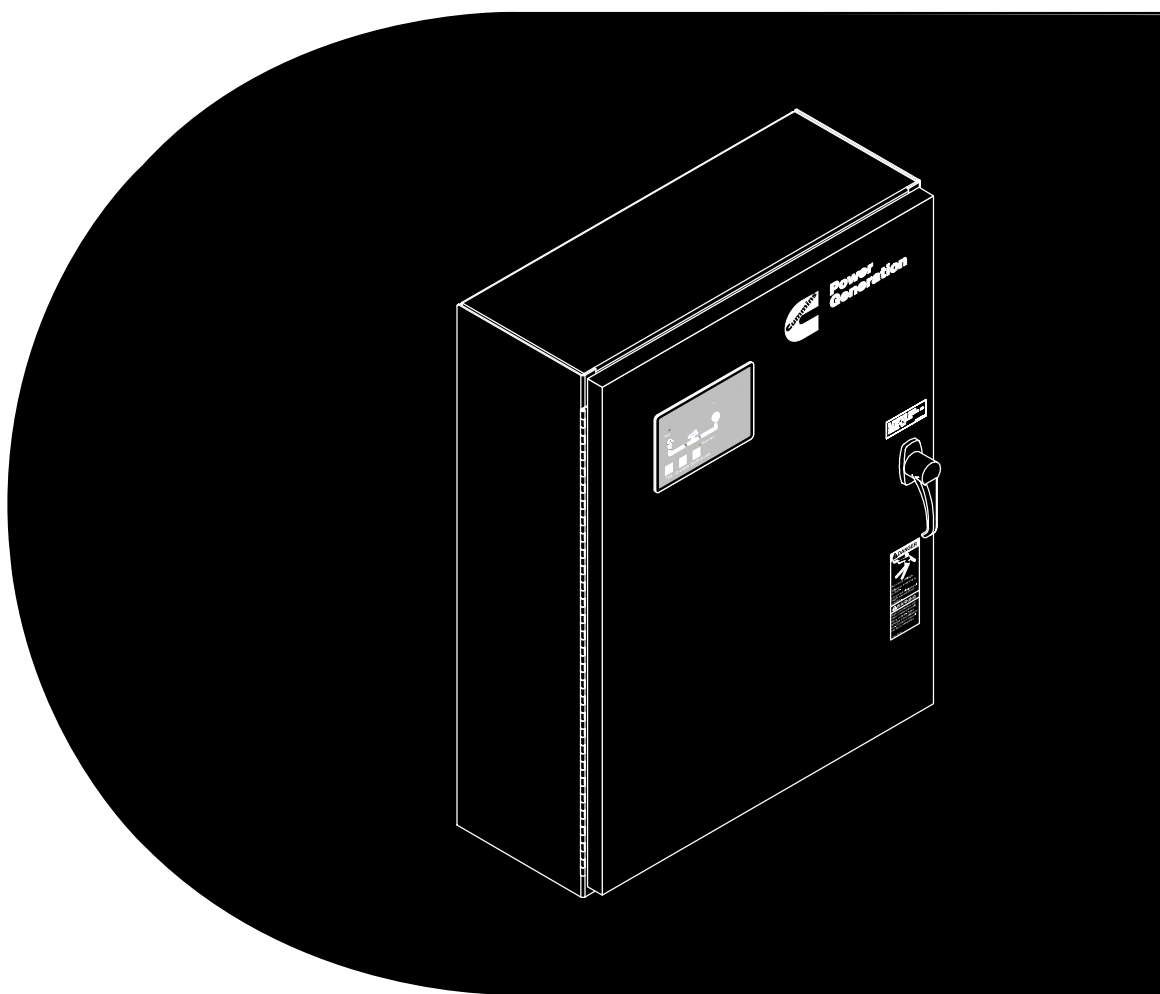

Table of Contents

SECTION	TITLE	PAGE
	SAFETY PRECUATIONS	iv
1.	INTRODUCTION	1-1
	Operator's Manual	1-1
	Transfer Switch Application	1-2
	Transfer Switch Function	1-2
	Model Identification	1-3
	How to Obtain Service	1-4
	Installation Overview	1-5
	Application and Installation	1-5
	Safety Considerations	1-6
	GTEC Features	1-6
2.	TRANSFER SWITCH START-UP	2-1
3.	DESCRIPTION	3-1
	Cabinet	3-1
	Control Panel	3-4
	Control Function LEDs	3-4
	ATS Status LEDs	3-4
	Membrane Pushbuttons	3-4
	Electronic Control System	3-6
	Transfer Inhibit Input	3-6
	Retransfer Inhibit Input	3-6
	Remote Test Input	3-7
	Two-Wire Starting	3-7
	Transfer Switch	3-7
	Contact Assemblies	3-7
	Electro Mechanical Actuator	3-7
	Auxiliary Contacts	3-8
	Voltage Sensing	3-8
	Line-to-Neutral Voltage Sensing	3-8
	Line-to-Line Voltage Sensing	3-8
	Options	3-9
	Float Battery Charger Option	3-9
	2-Amp Battery Charger	3-9
	Premium 2-Amp Battery Charger	3-9
	External Exercise Clock Option	3-10
	Elevator Relay Option	3-10
	Manual Restore Option	3-11
4.	OPERATION	4-1
	Time Delays	4-1
	Time Delay Engine Start (TDES)	4-1
	Time Delay Engine Cooldown (TDEC)	4-1
	Time Delay Normal to Emergency (TDNE)	4-1
	Time Delay Emergency to Normal (TDEN)	4-1
	Time Delay Programmed Transition (TDPT)	4-2
	Time Delay Elevator (TDEL) Pre-Transfer	4-2
	Elevator Post Transfer Delay	4-2

Table of Contents (continued)

SECTION	TITLE	PAGE
	Manual Operation	4-3
	Pushbutton Operation	4-4
	Test Pushbutton	4-4
	Override Pushbutton	4-4
	Set Exercise Pushbutton	4-4
	Test With or Without Load	4-5
	Test With Load Sequence of Events	4-5
	Test Without Load Sequence of Events	4-6
	Sensors	4-7
	Utility Sensor	4-7
	Generator Sensor	4-7
	Phase Check Sensor	4-7
	Return to Programmed Transition	4-7
	Generator Set Exerciser	4-8
	Exercise With or Without Load	4-8
	Integrated Exerciser	4-8
	Optional External Exerciser	4-10
	Exercise With or Without Load	4-10
	Using the Menu Button	4-11
	Using the +/- Buttons	4-11
	Using the ok Button	4-11
	Setting the Clock with Summer/Winter Time (Daylight Savings Time)	4-11
	Setting Exercise Start and Stop Times	4-14
	Checking the Programs	4-17
	Erasing (Clearing) A Programmed Exercise Period	4-20
	Erasing (Clearing) All Programmed Exercise Periods	4-21
	Initiating or Overriding an Exercise Program	4-22
	Selecting Permanent On/Off Mode	4-23
	Adding A Security Code	4-24
	After Programming the Exerciser Clock	4-25
	Resetting the Timer	4-25
	Planned Maintenance	4-27
5.	CONTROL PANEL CONFIGURATION	5-1
	Accessing the Front Panel Configuration Editor	5-1
	Modifying the Configuration	5-4
6.	INSTALLATION – MOUNTING	6-1
	Location	6-1
	Mounting Methods	6-1
	Wall Mounting	6-1
	Free-Standing	6-3
	Open Construction	6-3

Table of Contents (continued)

SECTION	TITLE	PAGE
7.	INSTALLATION – WIRING	7-1
	AC Connections	7-4
	Control Connections	7-6
	Connecting Transfer Switch to Genset	7-6
	Auxiliary Contacts	7-7
	Remote Start-Stop Connections	7-7
	Remote Test Input	7-8
	Transfer Inhibit Input	7-8
	Retransfer Inhibit Inhibit	7-8
	Remote Override Input	7-9
	Inspection and Cleanup	7-10
8.	TROUBLESHOOTING	8-1
	Control Panel LED Indicators	8-1
	Troubleshooting Procedures for Operators and Service Personnel	8-3
	Power Outage Occurs, But Generator Set Does Not Start	8-3
	Generator Set Starts During Normal Power Service	8-4
	Generator Set Does Not Exercise	8-4
	After a Power Failure, the Generator Set Starts But Does Not Assume the Load	8-5
	After Power Returns, the Transfer Switch Does Not Return To Normal Position	8-5
	Generator Set Continues to Run After Retransfer of Load to Normal Power ...	8-6
	System Does Not Test With Load	8-6
	System Does Not Exercise With Load	8-6
	External Exercise Clock Does Not Start An Exercise	8-7
	External Exerciser Does Not Repeat an Exercise	8-7
	Battery Charger Fails To Charge (If Equipped)	8-7
	Battery Loses Water	8-7
	Battery Loses Charge	8-7
	Troubleshooting Procedures for Experienced Service Personnel	8-8
	About Customer Inputs	8-8
	Control Panel LED Indicators	8-8
	Sequence of Events	8-10
	Normal to Emergency Sequence of Events	8-10
	Emergency to Normal Sequence of Events	8-13
	Troubleshooting With Symptoms	8-17
	Transfer Switch Operation	8-17
	Utility Power Failure	8-18
	Utility Power Is Restored	8-21
	Miscellaneous Troubleshooting Issues	8-24
9.	TRANSFER SWITCH SERVICE	9-1
	Switch Assembly Removal/Replacement Procedure	9-1
	Switch Removal and Replacement Procedure	9-1
	Disconnect AC Power	9-1
	Transfer Switch Assembly Removal	9-1
	Transfer Switch Replacement	9-1
	Reconnecting AC Power (When Finished)	9-2
10.	PARTS INFORMATION	10-1
11.	OUTLINE DRAWINGS AND WIRING DIAGRAMS	11-1

Safety Precautions

This manual includes the following symbols to indicate potentially dangerous conditions. Read the manual carefully and know when these conditions exist. Then take the necessary steps to protect personnel and the equipment.

⚠ DANGER *This symbol warns of immediate hazards that will result in severe personal injury or death.*

⚠ WARNING *This symbol refers to a hazard or unsafe practice that can result in severe personal injury or death.*

⚠ CAUTION *This symbol refers to a hazard or unsafe practice that can result in personal injury or product or property damage.*

ELECTRICAL SHOCK CAN CAUSE SEVERE PERSONAL INJURY OR DEATH

High voltage in transfer switch components presents serious shock hazards that can result in severe personal injury or death. Read and follow these suggestions.

Keep the transfer switch cabinet closed and locked. Make sure only authorized personnel have the cabinet keys.

Due to the serious shock hazard from high voltages within the cabinet, all service and adjustments to the transfer switch must be performed only by an electrician or authorized service representative.

UTILITY-TO-GENSET APPLICATIONS

If the cabinet must be opened for any reason:

1. Move the operation selector switch on the generator set to Stop.
2. Disconnect the battery charger.
3. Disconnect the starting batteries of the generator set or sets (remove the ground [-] lead first).
4. Remove AC power to the automatic transfer switch. If the instructions require otherwise, use extreme caution due to the danger of shock hazard.

GENERAL PRECAUTIONS

Place rubber insulative mats on dry wood platforms over metal or concrete floors when working on any electrical equipment. Do not wear damp clothing (particularly wet shoes) or allow skin surfaces to be damp when handling any electrical equipment.

Jewelry is a good conductor of electricity and should be removed when working on the electrical equipment.

Wear safety glasses whenever servicing the transfer switch and do not smoke near the batteries.

Do not work on this equipment when mentally or physically fatigued, or after consuming alcohol or any drug that makes the operation of equipment unsafe.

⚠ WARNING

INCORRECT SERVICE OR REPLACEMENT OF PARTS CAN RESULT IN DEATH, SEVERE PERSONAL INJURY, AND/OR EQUIPMENT DAMAGE. SERVICE PERSONNEL MUST BE QUALIFIED TO PERFORM ELECTRICAL AND/OR MECHANICAL SERVICE.

1. Introduction

OPERATOR'S MANUAL

This manual covers models produced under the Cummins® Power Generation brand names.

This manual provides information necessary for operation, installation, and service of an GTEC transfer switch. This manual also includes parts information.

This is an open transition transfer switch that includes an automatic transfer switch (ATS) control. With an open transition switch, there is never a time when both sources are supplying power to the load.

Programmed transition switches briefly pause in the neutral position of the transfer switch, between switched positions, so that transient voltages from the load can diminish before the load is switched to the other source.

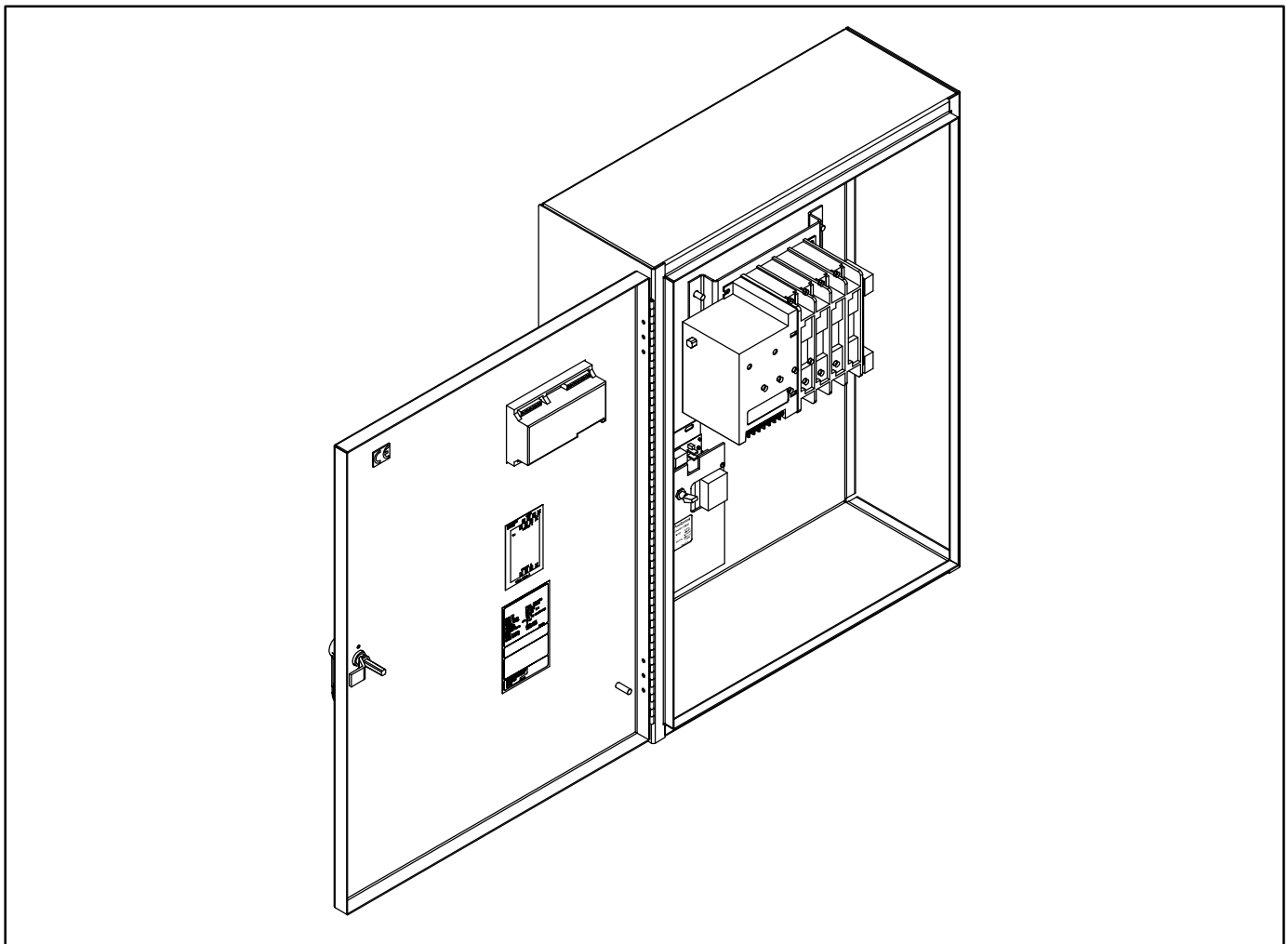

FIGURE 1-1. GTEC TRANSFER SWITCH WITH DOOR OPEN (125 AMP, 4 POLE SWITCH SHOWN WITH OPTIONAL 2 AMP BATTERY CHARGER)

Copyright© 2006 Cummins Power Generation. All rights reserved.
Cummins, Onan, and PowerCommand are registered trademarks of Cummins Inc.

TRANSFER SWITCH APPLICATION

Transfer switches are an essential part of a building's standby or emergency power system. The utility line (normal power), is backed up by a generator set (emergency power). The transfer switch automatically switches the electrical load from one source to the other.

The load is connected to the common of the ATS (Figure 1-1). Under normal conditions, the load is supplied with power from the utility (as illustrated). If utility power is interrupted, the load is transferred to the generator set (genset). When utility power returns, the load is retransferred to the utility. The transfer and retransfer of the load are the two most basic functions of a transfer switch.

TRANSFER SWITCH FUNCTION

Automatic transfer switches, capable of automatic operation without operator intervention, perform the basic function of transferring the load to the available power source. The controller monitors each source for allowable voltage and frequency range.

This automatic transfer switch, capable of automatic operation without operator intervention, is designed for utility-to-genset applications. In utility-to-genset applications, the transfer switch performs the following functions:

1. Senses the interruption of utility power.
2. Sends a start signal to the genset.
3. Transfers the load to the genset.
4. Senses the return of utility power.
5. Retransfers the load to the utility.
6. Sends a stop signal to the genset.

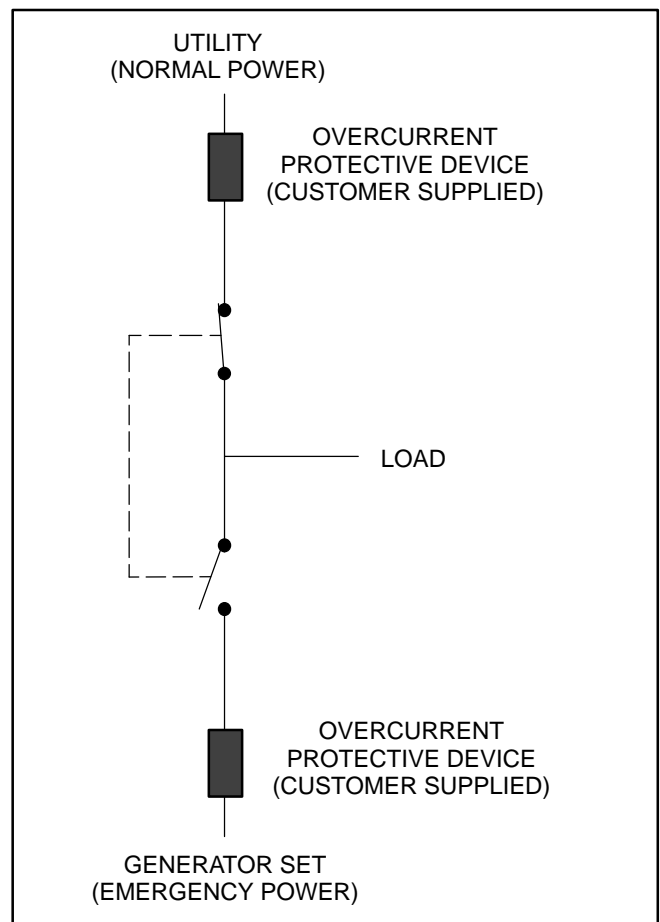

FIGURE 1-2. LOAD TRANSFER SWITCH (TYPICAL FUNCTION)

MODEL IDENTIFICATION

Identify your model by referring to the Model and Specification number as shown on the nameplate. Electrical characteristics are shown on the lower portion of the nameplate (see Figure 1-3), which is located on the cabinet door.

If it is necessary to contact a distributor regarding the transfer switch, always give the complete Model and Serial number. This information is necessary to properly identify your unit among the many types manufactured.

Cummins Power Generation	
Model No.	GT30160EQ5KA000
Serial No.	F05W000072
Current Rating:	160A
Voltage Rating:	110/190V
Frequency:	50 Hertz
Class:	PC
Utilization Category:	AC-31B
Feature: S903;R971;A028;A045;A035;B004;A042; L989;M034	
Enclosure Rating:	None
Application:	Utility to Genset
Wiring Diagram:	0630–2993
Outline Drawing:	0300–6012
Conditional Short Circuit Current:	38,000A @480 VAC
Fuse type:	RT16NT-2
Max. Fuse Rating:	250A
THIS PRODUCT CONFORMS TO EN 60947-6-1 AND EN 60439-1	

FIGURE 1-3. STANDARD NAMEPLATE

Model No:

The model number is made up of code segments that designate various features or options:

GT	3	0500	M	N	5	2	A	000
1	2	3	4	5	6	7	8	9

1. GT = GTEC - Global transfer switch with open transition and delay transition

2. Number of Poles: 2, 3, or 4
3. Current Rating: 63, 100, 125, 160, 200, 225, 250, 350, 400, 500, 630, 800, 1000, or 1250 amps

4. Voltage Code:

A = 110 VAC*
 B = 115 VAC*
 C = 120 VAC*
 D = 127 VAC*
 E = 110/190 VAC**
 F = 115/200 VAC**
 G = 120/208 VAC**
 H = 127/220 VAC**
 I = 220 VAC*
 J = 230 VAC*
 K = 240 VAC*
 L = 139/240 VAC**
 N = 220/380 VAC**
 O = 230/400 VAC**
 P = 240/416 VAC**
 Q = 255/440 VAC**
 S = 277/480 VAC**
 X = 110/190V, 115/200V, 120/208V,
 127/220V, 139/240V
 Y = 220/380V, 230/400V, 240/416V
 Z = 255/440V, 277/480V

* = Single Phase, 2 Wire
 ** = Three Phase, 3 or 4 Wire OR
 Single Phase, 3 Wire

5. Control Type:

L = 12VDC, Powered Line-to-Line Sensing Control
 N = 12VDC, Powered Line-to-Neutral Sensing Control
 P = 24VDC, Powered Line-to-Line Sensing Control
 Q = 24VDC, Powered Line-to-Neutral Sensing Control

6. Frequency:

5 = 50 Hertz
 6 = 60 Hertz
 7 = 50/60 Hertz

7. Construction Type:

2 = IP32 Enclosure
 3 = IP54 Enclosure
 K = Kit (open construction)

8. Revision Letter:

Factory Assigned (A thru Z)

9. Spec Number:

Factory Assigned (000–999)

Serial No:

The serial number is made up of nine characters.

K	05	W	000001
1	2	3	4

1. Character 1 = Month manufactured
 - A = 1
 - B = 2
 - C = 3
 - D = 4
 - E = 5
 - F = 6
 - G = 7
 - H = 8
 - I = 9
 - J = 10
 - K = 11
 - L = 12
2. Characters 2 and 3 = Year built
 - 05 = 2005
3. Character 4 = Plant location:
 - 0 = Fridley, Minnesota
 - 1 = SML (Portables)
 - 2 = Cummins (USA)
 - 3 = Huntsville, Alabama
 - 4 = Onan Power Electronics
 - 5 = Singapore
 - 6 = Westinghouse (Transfer Switches and Breakers)
 - 7 = Canada (Linamar)
 - 8 = Lister-Petter
 - 9 = Kubota (K-Series Portables)
 - A = Australia (Dunlite and Adelaide)
 - B = South America (Columbia)
 - C = Italy (DIEM)
 - L = Libby
 - M = Libby (Military)
 - R = Robin (Fuji Engines) USA
 - U = PGI
 - K = UK (Kent)
 - S = Mexico (Cumsa)
 - T = Brazil
 - X = Canada (Linamar – early production)
 - W = Nexage Wuxi, China
4. Characters 5 thru 10 = Manufacturing Order Number (Sequentially assigned number)

HOW TO OBTAIN SERVICE

When the transfer switch requires servicing, contact your nearest Cummins Power Generation distributor. Factory-trained Parts and Service representatives are ready to handle all your service needs.

To contact your local Cummins Power Generation distributor in the United States or Canada, call 1-800-888-6626 (this automated service utilizes touch-tone phones only). By selecting Option 1 (press 1), you will be automatically connected to the distributor nearest you.

If you are unable to contact a distributor using the automated service, consult the Yellow Pages. Typically, our distributors are listed under:

Generators-Electric,
Engines-Gasoline or Engines-Diesel, or
Recreational Vehicles-Equipment,
Parts and Service.

In Asia, contact:

Cummins Diesel Sales Corporation
8 Tanjong Penjuru
Singapore 609019
(+65) 6265-0155

In Great Britain, contact the CPGK Aftermarket Group:

Aftermarket Group
Cummins Power Generation Pty Ltd
Manston Park
Columbus Avenue, Manston
Ramsgate, Kent CT12 5BF
England, UK
Phone: +44 (0) 1843 255000
Parts Support:
Email: cpgk.parts@cummins.com
Service Support;
Email: cpgk.aftermarket.helpline@cummins.com

For other locations outside North America, call Cummins Power Generation, 1-763-574-5000, 7:30 AM to 4:00 PM, Central Standard Time, Monday through Friday. Or, send a fax to Cummins Power Generation using the fax number 1-763-528-7229.

When contacting your distributor, always supply the complete Model, Specification, and Serial Number as shown on the equipment nameplate.

INSTALLATION OVERVIEW

These installation recommendations apply to typical installations. Whenever possible, these recommendations also cover factory designed options or modifications. However, because of the many variables in any installation, it is not possible to provide specific recommendations for every situation. If there are any questions not answered by this manual, contact your nearest Cummins/Onan distributor for assistance.

Application and Installation

Installations must be carefully planned and correctly installed for proper operation. This involves two essential elements: application and installation.

Application refers to the design of the complete standby power system that usually includes power distribution equipment, transfer switches, ventila-

tion equipment, mounting pads, cooling systems, exhaust systems, and fuel systems. Each component must be correctly designed so the complete system functions as intended. Application and design is an engineering function generally done by specifying engineers or other trained specialists. Specifying engineers are responsible for the design of the complete standby system and for selecting the materials and products required.

Installation refers to the actual set-up and assembly of the standby power system. The installers set up and connect the various components of the system as specified in the system design plan. The complexity of the standby system normally requires the special skills of qualified electricians, plumbers, sheet metal workers, etc. to complete the various segments of the installation. This is necessary so all components are assembled using standard methods and practices.

Safety Considerations

The transfer switch has been carefully designed to provide safe and efficient service when properly installed, maintained, and operated. However, the overall safety and reliability of the complete system depends on many factors outside the control of the manufacturer. To avoid possible safety hazards, make all mechanical and electrical connections to

the transfer switch exactly as specified in this manual. All systems external to the transfer switch must comply with all applicable codes. Make certain all required inspections and tests have been completed and all code requirements have been satisfied before certifying the installation is complete and ready for service.

Verify that both power source voltages match the nameplate rating prior to installation.

GTEC FEATURES

FEATURE DESCRIPTION	FEATURE OPTION
Poles: 2 Poles 3 Poles 4 Poles	A027 A028 A029
Application: Utility to Genset	A035
Frequency: 60 Hertz 50 Hertz	A044 A045
Phase: Single Phase, 2 or 3 Wire Three Phase, 3 or 4 Wire	A041 A042
Cabinet: IP32 IP54 Open Construction	B901 B014 B004
Battery Chargers: 2 Amp, 12/24VDC	K001-7
Voltage Ratings: 110/190 VAC 115/200 VAC 120/208 VAC 127/220 VAC 139/240 VAC 220/380 VAC 230/400 VAC 240/416 VAC 255/440 VAC 277/480 VAC 110VAC 115VAC 120VAC 127VAC 220VAC 230VAC 240VAC	R971 R972 R973 R974 R975 R976 R977 R978 R979 R980 R981 R982 R983 R984 R985 R986 R987

FEATURE DESCRIPTION	FEATURE OPTION
Current Ratings: 63 Amp 100 Amp 125 Amp 160 Amp 200 Amp 225 Amp 250 Amp 350 Amp 400 Amp 500 Amp 630 Amp 800 Amp 1000 Amp 1250 Amp	S901 S902 S048 S903 S904 S905 S906 S907 S053 S908 S909 S055 S056 S910
Control Options: External Exercise Clock Elevator Signal Relay Manual Restore Switch	J030-7 M032-7 S006-7
Auxiliary Relays: 24 VDC Coil Emergency Position Normal Position 12 VDC Coil Emergency Position Normal Position	L101-7 L102-7 L103-7 L201-7 L202-7 L203-7
Miscellaneous: Terminal Block – 10 Position	M002-7
Controller Type: Line to Neutral Line to Line	L989 L990
Starting Battery: 12V, Genset Starting Voltage 24V, Genset Starting Voltage	M033 M034
Neutral Connection: Neutral Bar Assembly	N016-7

2. Transfer Switch Start-Up

The GTEC transfer switch is preset at the factory to operate using default settings. The control will operate the transfer switch when power is applied. However, you may wish to adjust some of the settings for better performance.

The transfer switch must be installed correctly, with DC power present, before any adjustments to the configuration can be made. If the transfer switch is connected to utility power, the Utility Power Connected LED will be lit if battery power is available. Utility or genset voltage need not be present to adjust the configuration.

The following tables show which control functions should not be changed (Table 2-1) and which functions can be changed for your application (Table 2-2). Refer to *Section 5* for more details.

TABLE 2-1. FUNCTIONS THAT SHOULD NOT BE CHANGED

Function	Factory Setting
System Nominal Voltage Table	Set for your system voltage
System Nominal Voltage	Set for your system voltage
System Nominal Frequency	Set for your system frequency
System Phase	Set for your system
External Exercise	Set to "On" if the external exerciser option was ordered; otherwise, set to "Off"

TABLE 2-2. FUNCTIONS THAT CAN BE CHANGED

Function	Factory Setting
TDES (Time Delay Engine Start)	3 Seconds
TDNE (Time Delay Normal to Emergency)	5 Seconds
TDEN (Time Delay Emergency to Normal)	10 Minutes
TDEC (Time Delay Engine Cooldown)	10 Minutes
TDPT (Time Delay Programmed Transition)	0 Seconds
TDEL (Time Delay Elevator Signal)	0 Seconds
Test With or Without Load	Without Load
Exercise With or Without Load	Without Load
Utility Undervoltage Pickup	90%
Utility Undervoltage Dropout	85%
Phase Check	Off
Return to Programmed Transition	Off
Elevator Post Transfer Delay	Off
Exercise Repeat Interval	Every 7 Days

THIS PAGE LEFT INTENTIONALLY BLANK

3. Description

This section describes the control cabinet, the switch mechanism, and the standard and optional control features available with the GTEC transfer switch.

CABINET

The GTEC transfer switch uses an IP32 type cabinet. These Ingress Protection (IP) cabinets are de-

signed to prevent entrance of foreign objects that are 2.5 mm and larger and can keep out falling drops of water up to a 15-degree incidence angle.

Examples of cabinets are shown in Figures 3-1 thru 3-3.

The GTEC is also available for open construction installations.

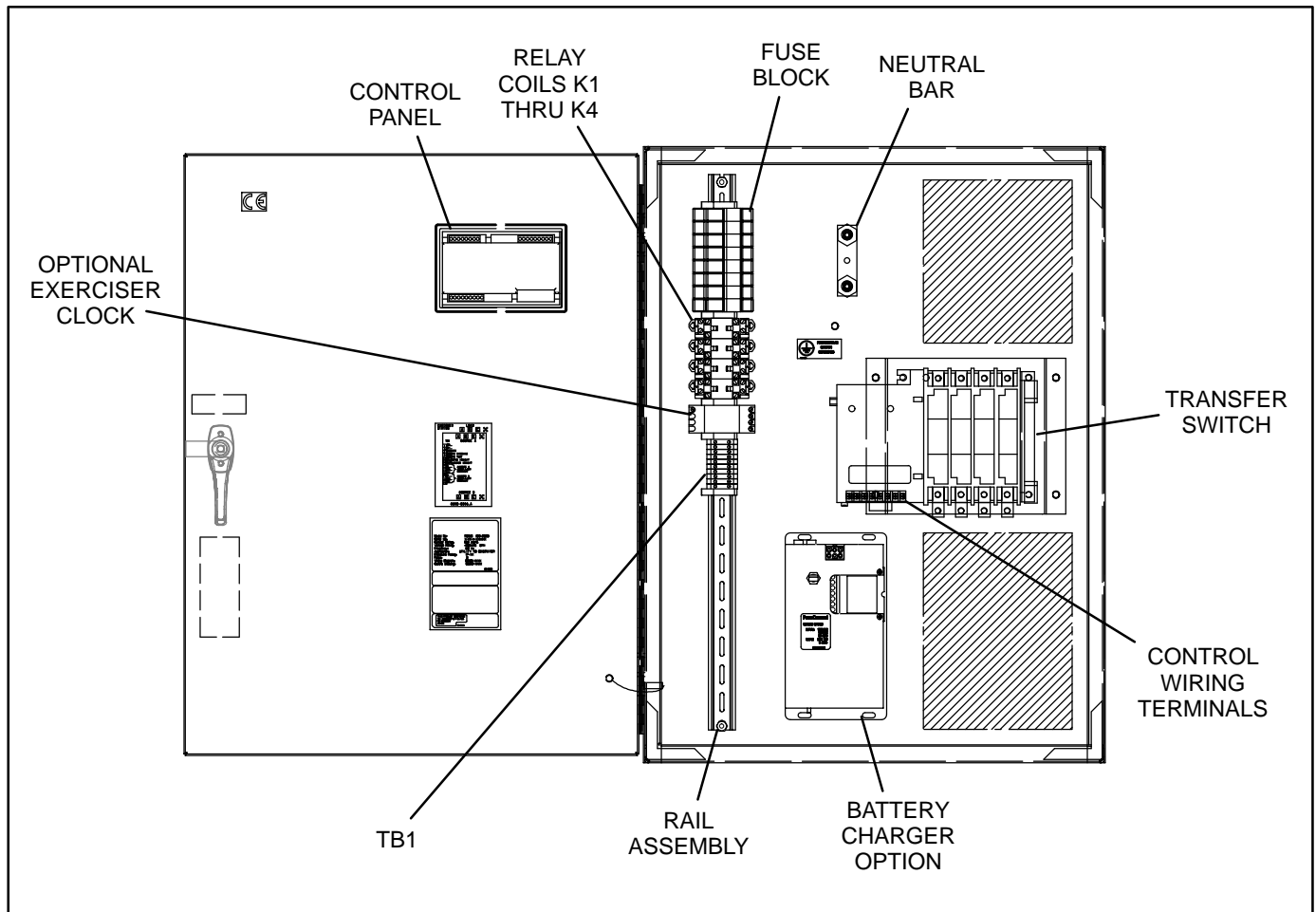

FIGURE 3-1. INTERIOR COMPONENTS: 63-125 AMP, 4 POLE SWITCH

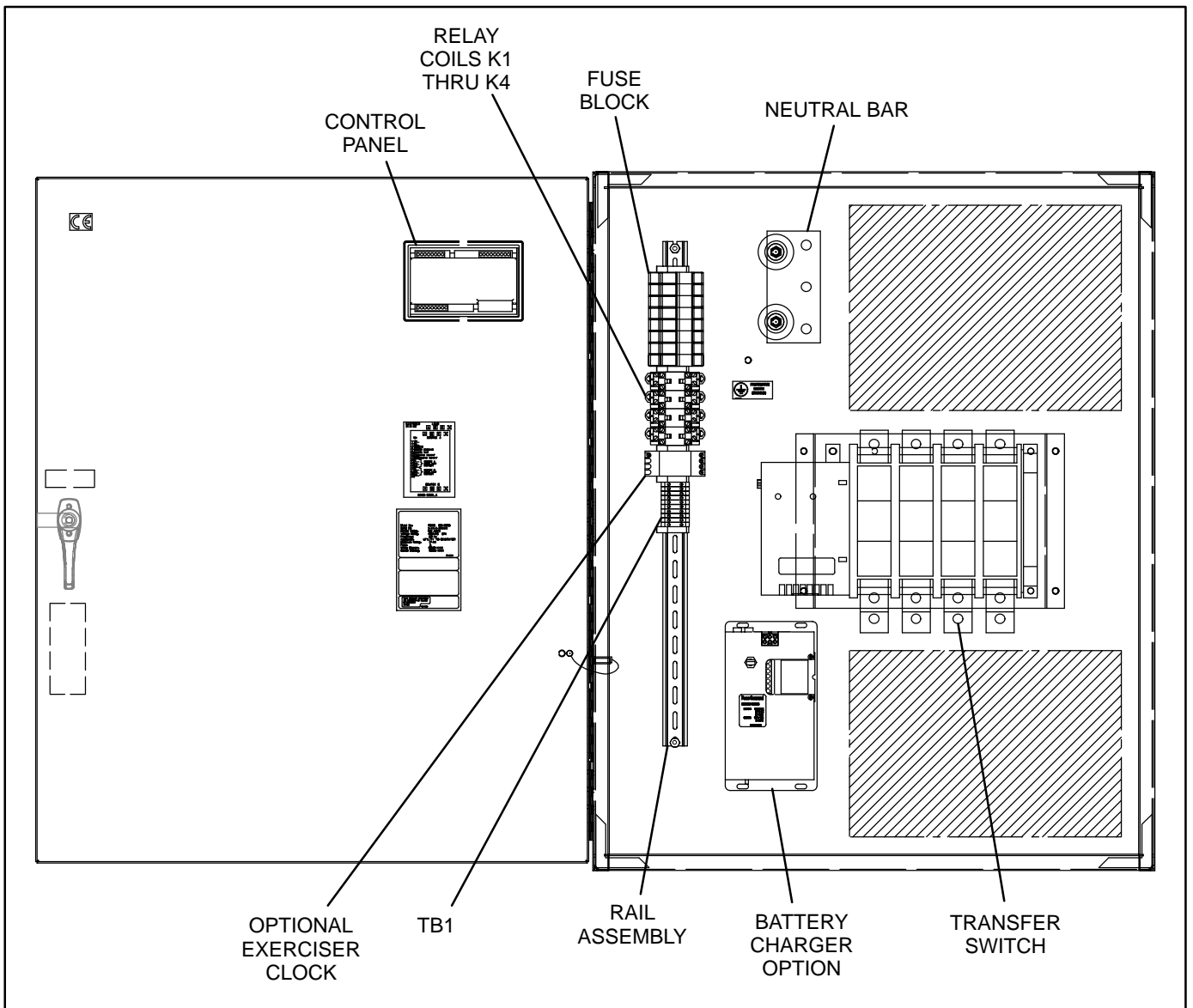

FIGURE 3-2. INTERIOR COMPONENTS: 160-500 AMP, 4 POLE SWITCH

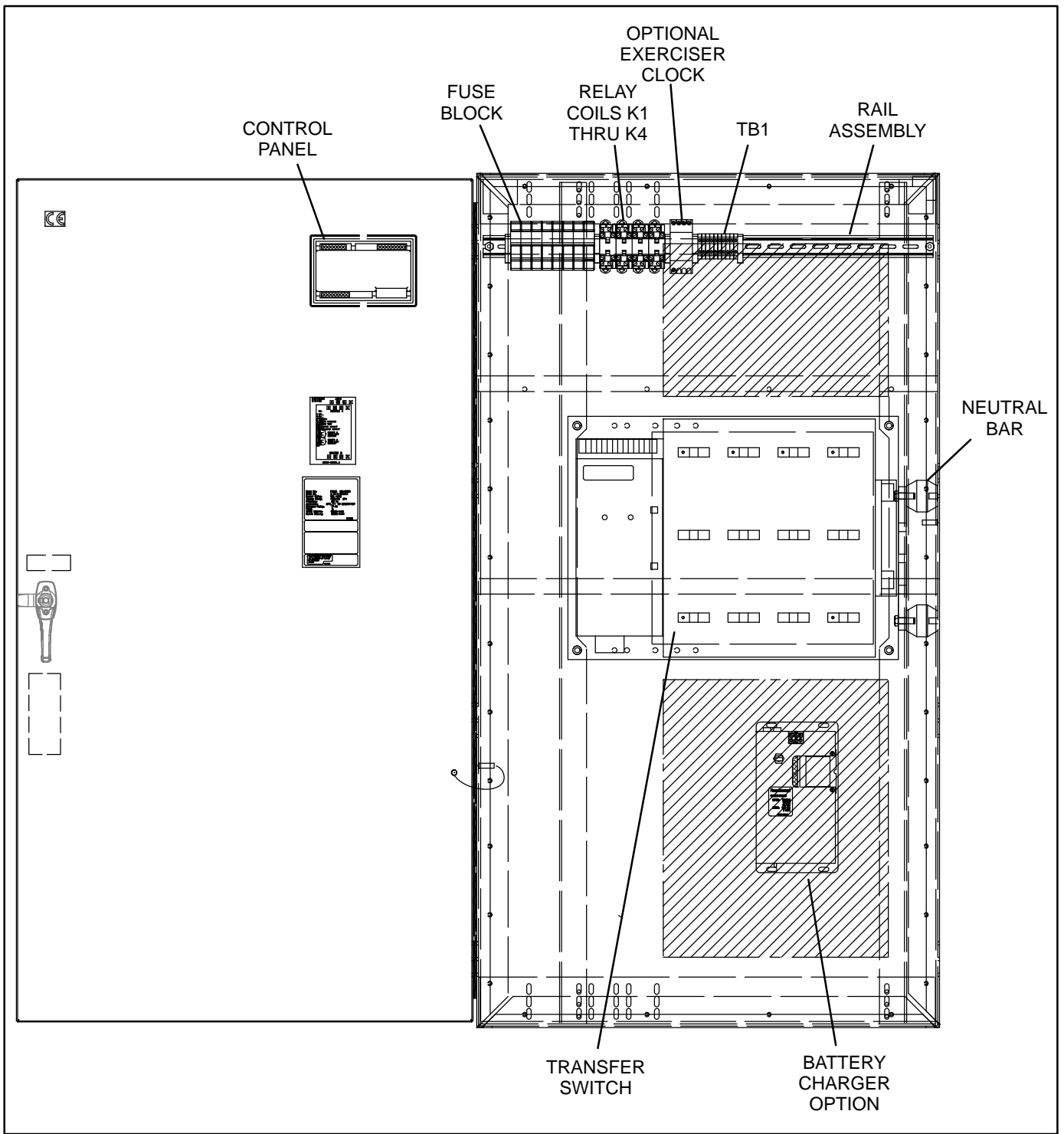

FIGURE 3-3. INTERIOR COMPONENTS: 630-1250 AMP, 4 POLE SWITCH

CONTROL PANEL

Figure 3-4 shows the control panel on the cabinet door. Two types of controls are available with GTEC transfer switches.

- TS1311 controls are used on transfer switches with line-to-neutral voltage sensing.
- TS1310 controls are used on transfer switches with line-to-line voltage sensing.

The front of the control panel is the same for both types of controls.

The control features are divided into three groups:

- Control Function LEDs
- ATS Status LEDs
- Membrane Pushbuttons

Control Function LEDs

The control panel (see Figure 3-4) includes eight LEDs that display codes that indicate various control functions that can be configured. The first five LEDs display the function code and the last three LEDs display the value code for the displayed function. For information on configuring these functions, see *Section 5*.

With the exception of the first LED (Test), normally these LEDs are off and are only lit when in Configuration Mode. The Test LED is also used to notify the user of test periods.

ATS Status LEDs

The control panel includes six LEDs that provide Automatic Transfer Switch (ATS) status information.

Utility Power Available – This green LED is lit when the utility power source has acceptable output voltage.

Genset Power Available – This amber LED is lit when the genset power source has acceptable output voltage and frequency.

Both power source LEDs can be lit simultaneously.

Utility Power Connected – This green LED is lit when utility power is supplying power to the load.

This LED flashes once per second if there is a failure to connect to or disconnect from utility power, when commanded. The control makes five attempts (there is ten seconds between each attempt) to connect to or disconnect from utility power before it flashes the failure.

Genset Power Connected – This amber LED is lit when the genset is supplying power to the load.

This LED flashes once per second if there is a failure to connect to or disconnect from the genset, when commanded. The control makes five attempts (there is ten seconds between each attempt) to connect to or disconnect from the genset before it flashes the failure.

Test – This amber LED is lit when there is an active test period. This LED flashes twice per second when the Test pushbutton is pressed to set or cancel a test period.

Exercise – This amber LED lights when repeat exercise periods have been set. This LED flashes twice per second when the Set Exercise pushbutton is pressed to set or cancel an exercise. This LED flashes once per second during an active exercise period.

Membrane Pushbuttons

The control panel includes three membrane pushbuttons.

Test – The Test pushbutton is used to set or cancel a test period. The control can be configured to test the genset with or without load. For more information, see *Section 4*.

The Test pushbutton is also used in the Configuration Mode to step through the function codes (see *Section 5*).

Override – The Override pushbutton is used to terminate or bypass some time delays, to stop the Power Connected LEDs from flashing as a result of a failure to connect to or disconnect from a power source, and to cancel an active exercise period. For more information, see *Section 4*.

The Override pushbutton is also used in the Configuration Mode to step through the value codes (see *Section 5*).

Set Exercise – The Set Exercise pushbutton is used to set or cancel repeat exercise periods using the integrated exerciser. For more information, see “Integrated Exercises” on page 4-8.

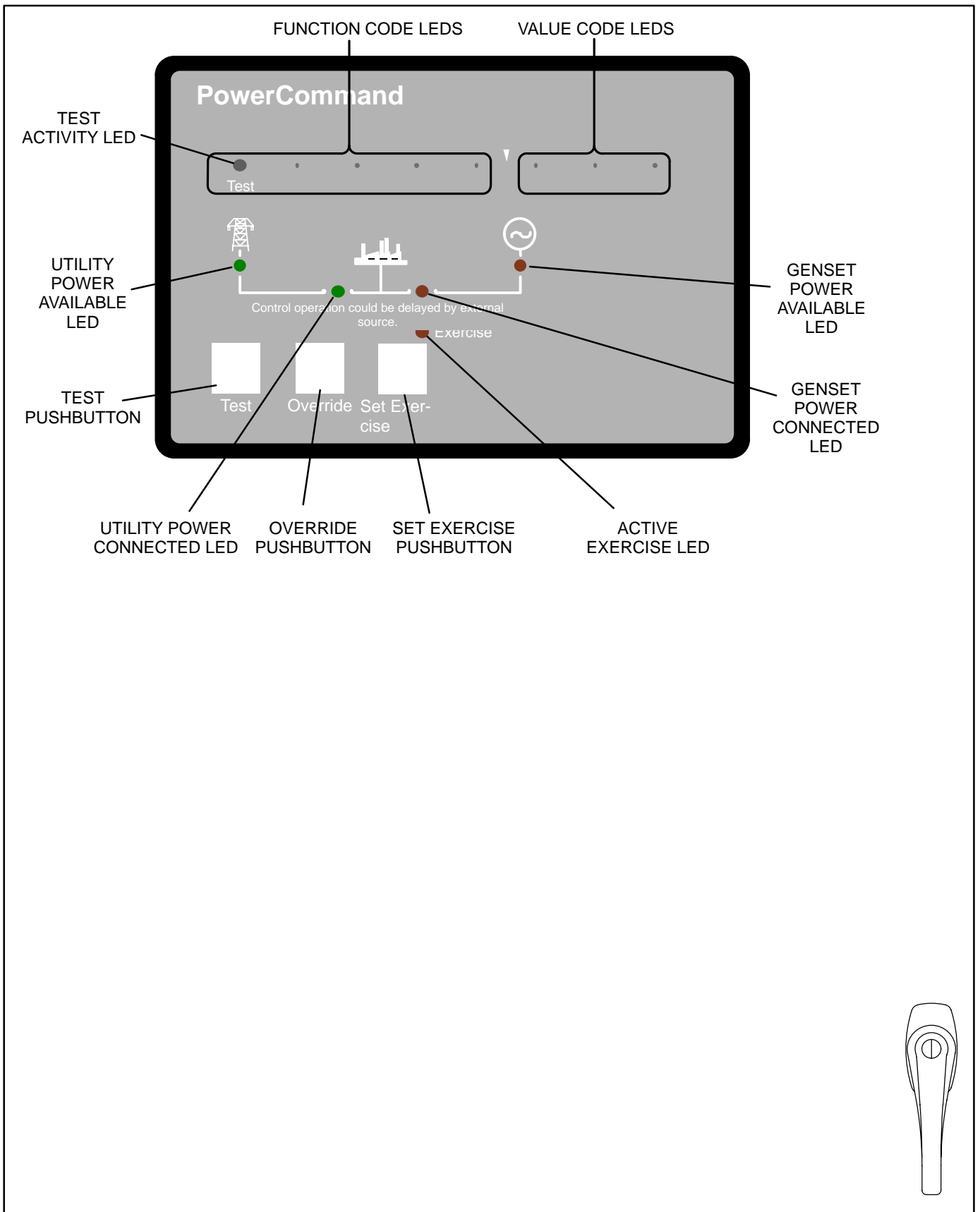

FIGURE 3-4. CABINET DOOR

ELECTRONIC CONTROL SYSTEM

This section describes the standard and optional components of the electronic control system.

⚠WARNING *Improper calibration or adjustment of electronic control modules can cause death, severe personal injury, and equipment or property damage. Calibration and adjustment of these components must be performed by technically qualified personnel only.*

Installation of these components and calibration and adjustment procedures are described in Section 7.

⚠WARNING *AC power within the cabinet and the rear side of the cabinet door presents a shock hazard that can cause severe personal injury or death. When the cabinet door is open, use extreme caution to avoid touching electrical contacts with body, tools, jewelry, clothes, hair, etc.*

Transfer Inhibit Input

A transfer inhibit input is set up by connecting a dry (voltage free) contact between TB1-6 and TB1-8. Closing the contact enables the feature and opening the contact disables it.

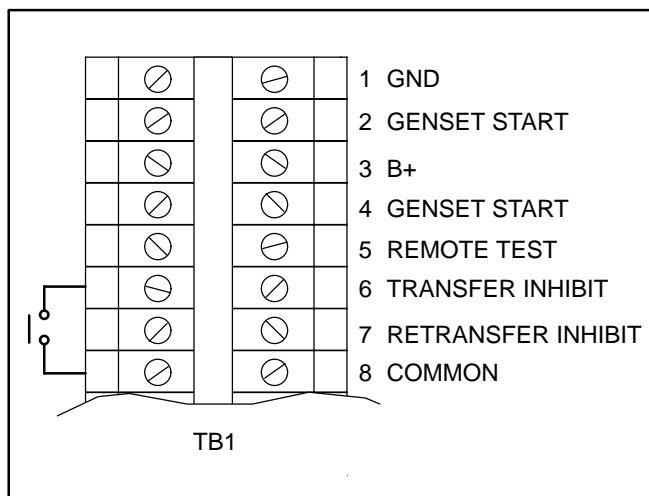

FIGURE 3-5. TB1 CONNECTIONS FOR TRANSFER INHIBIT

This feature is used to control load transfer to gensets. When enabled, load transfer will not take place unless the Override pushbutton on the control panel is pressed or the transfer inhibit input is disabled.

Pressing the Override pushbutton on the control panel bypasses the transfer inhibit input and bypasses TDNE. The TDNE runs if the transfer inhibit input is disabled.

Retransfer Inhibit Input

A retransfer inhibit input is set up by connecting a dry (voltage free) contact between TB1-7 and TB1-8. Closing the contact enables the feature and opening the contact disables it.

This feature is used to prevent the ATS from automatically transferring the load back to the utility. When enabled, load transfer will not take place unless the Override pushbutton on the control panel is pressed, the retransfer inhibit input is disabled, or the genset fails. If the genset fails, retransfer inhibit is ignored.

Pressing the Override pushbutton on the control panel bypasses the retransfer inhibit input and bypasses the TDEN. The TDNE runs if the retransfer inhibit input is disabled.

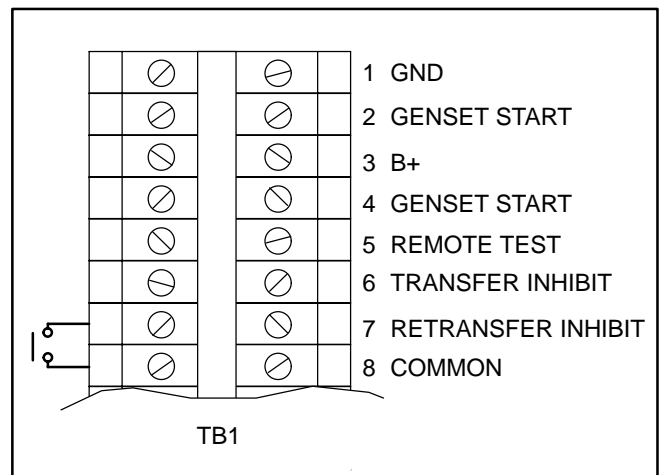

FIGURE 3-6. TB1 CONNECTIONS FOR RETRANSFER INHIBIT

Remote Test Input

The transfer switch may be wired for a remote test input. The switch is used to start and stop manually initiated system tests. As with the control panel Test pushbutton, the remote test input can be configured to test with or without load. More information on testing is included in *Section 4*.

A remote test input is set up by connecting a dry (voltage free) contact between TB1-5 and TB1-8. Closing the contact starts a test and opening the contact cancels the test. The Test LED flashes to signify the start of a test and stays on during the test.

Closing the contact causes the transfer switch to sense a (simulated) utility power failure and sends a start/run signal to the genset. If the control is set up to test with load, the load is transferred to the genset when the genset becomes available. The Utility Power Available LED remains on to show that the utility did not fail.

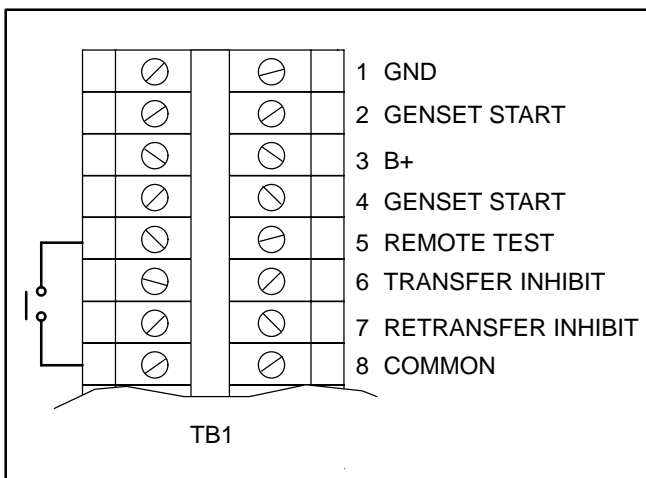

FIGURE 3-7. TB1 CONNECTIONS FOR REMOTE TEST TRANSFER

Two-Wire Starting

The starting circuit is a basic supervisory function of the electronic control. Water-cooled generator sets use a two-wire start control.

Although the logic is more involved, the two-wire starting circuit can be thought of as a single pole, single throw switch. A closed switch starts the generator set. An open switch stops the generator.

NOTE: Three-wire starting is not available on GTEC transfer switches.

TRANSFER SWITCH

The transfer switch (see Figures 3-1 thru 3-3) opens and closes the contacts that transfer the load between the power sources. The switch is mechanically interlocked to prevent simultaneous closing to both power sources. The main parts of the switch discussed here are the contact assemblies, linear actuator, and auxiliary contacts.

Contact Assemblies

The automatic transfer switch has either two, three, or four poles. Three pole transfer switches are provided with a neutral bar. The contact assemblies make and break the current flow. When closed to either power source the contacts are mechanically held. A mechanical interlock prevents them from closing to both power sources at the same time.

Electro Mechanical Actuator

Actuator operation is initiated automatically by the transfer switch control. Manual operation of the switch is also possible. Refer to Manual Operation in *Section 4*.

Auxiliary Contacts

Auxiliary contacts are provided on the utility and genset sides of the transfer switch (see Figure 3-8). They are actuated by operation of the transfer switch during transfer and retransfer. The utility auxiliary contact switch is actuated when the transfer switch connected to the utility. The genset auxiliary contact switch is actuated when the transfer switch is connected to the genset. The auxiliary contacts have current ratings of 5 amperes at 250 VAC. The contacts are wired to terminal block TB1.

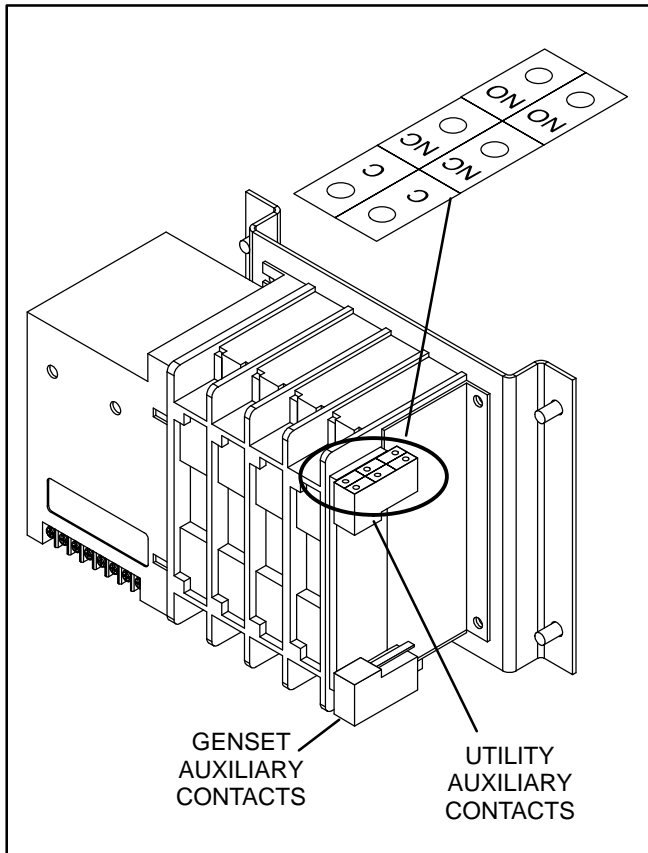

FIGURE 3-8. AUXILIARY CONTACTS

VOLTAGE SENSING

GTEC transfer switches are available with either line-to-neutral or line-to-line voltage sensing.

Line-to-Neutral Voltage Sensing

The following is true if your transfer switch is configured for line-to-neutral voltage sensing.

- There is a letter “N” or “Q” in the model number just after the voltage code.
- The controller is identified as TS1311 on the white label on its case.
- The P3 connector on the back of the controller has 11 pins.

Line-to-Line Voltage Sensing

The following is true if your transfer switch is configured for line-to-line voltage sensing.

- There is a letter “L” or “P” in the model number just after the voltage code.
- The controller is identified as TS1310 on the white label on its case.
- The P3 connector on the back of the controller has 9 pins.

OPTIONS

Float Battery Charger Option

A float-charge battery charger (Figure 3-9) regulates its charge voltage to continuously charge without damage to the battery. As the battery approaches full charge, the charging current automatically tapers to zero amperes or to steady-state load on the battery.

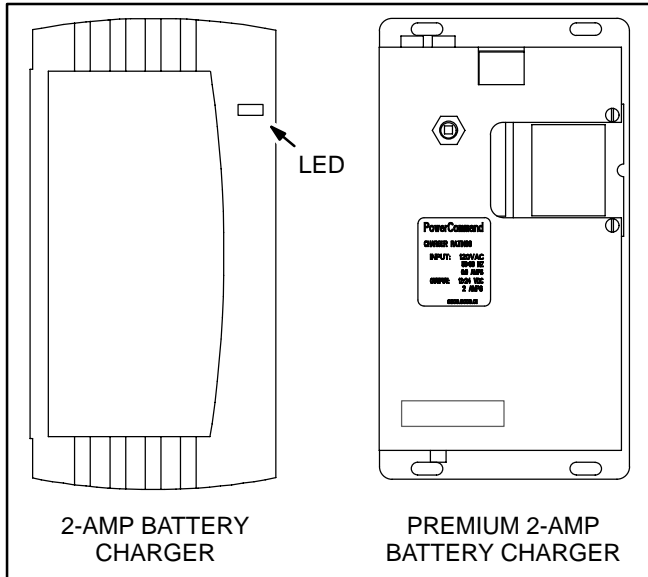

FIGURE 3-9. BATTERY CHARGERS

Two 2-amp battery chargers are available. One battery charger is compact and does not have a digital display. The other battery charger is a premium charger which includes a digital display. The premium battery charger is only available for field installation.

2-Amp Battery Charger

The input voltage range for the 2-amp battery charger is between 100 and 240 VAC. The maximum in-rush current at cold start is 15 amps for 115 VAC and 30 amps for 230 VAC.

The 2-amp battery charger includes one LED that displays the appropriate color for the following conditions.

- **Red** – On solid indicates the unit is charging
- **Green** – On solid indicates the unit is fully charged.

Premium 2-Amp Battery Charger

The 2-ampere battery charger has a 5 amp DC output circuit breaker switch on the front of the battery charger. The charger also includes a 5 amp AC fuse to protect the battery charger circuit.

Under normal operating conditions, the Low Bat and AC Fail relays are energized and the High Bat relay is de-energized. In response to a Low Bat or AC Fail condition, the appropriate normally energized relay (Low Bat or AC Fail) drops out. In response to a High Bat condition, the normally de-energized High Bat relay is energized.

Control Panel – The 2-amp charger control panel includes a digital display, a RESET button, and an LED status indicator (see Figure 3-10).

- The 2-line x 16-character digital display displays menus and faults.
- The RESET button is used to select menu options and to clear fault messages.
- The status LED is displays the appropriate color for the following conditions.
 - **Green** – On solid indicates unit is charging
 - **Red** – On solid indicates a fault condition. The fault number is shown on the digital display.

Battery Charger Configuration – The **RESET** button on the control panel (see Figure 3-10) is used to configure the battery charger for the correct battery voltage. (More information on Setup menus is included in the Battery Charger Operator's Manual.)

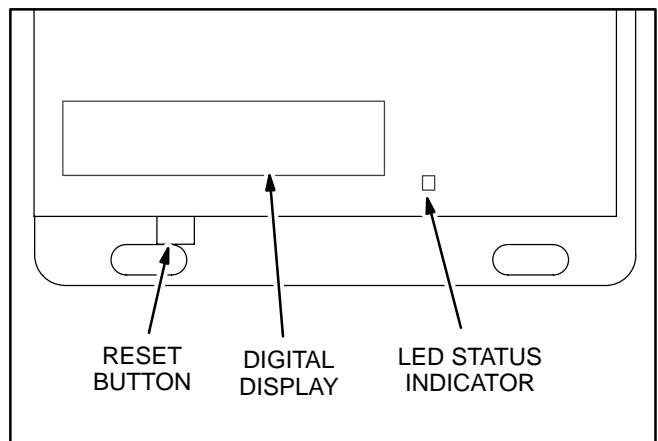

FIGURE 3-10. PREMIUM 2-AMP CHARGER CONTROL PANEL

External Exercise Clock Option

The optional external exercise clock includes a 7-day, real-time clock that keeps track of the time and date. The clock can be set for automatic changeover for summer/winter (Daylight Savings/Standard) time. The exercise clock can be used with 12 or 24 VDC operation.

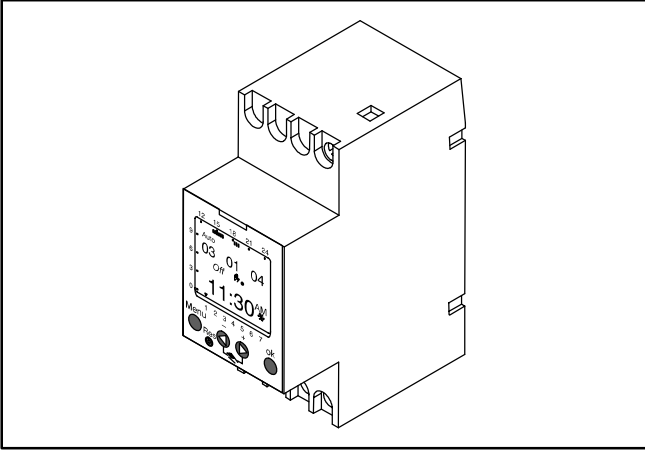

FIGURE 3-11. EXTERNAL EXERCISE CLOCK

Programs are available to set exercise start and stop times. One program is required to start an exercise period and a second one is required to stop an exercise period.

The exercise clock has a built-in test feature that can be used to initiate an exercise that hasn't been programmed or cancel a programmed exercise in process.

Information on setting the clock is included in *Section 4*.

NOTE:The clock includes a non-replaceable lithium battery with a life expectancy of at least ten years. If the clock battery is weak during a power failure, the clock will need to be replaced.

Elevator Relay Option

Connections to the elevator relay are made directly to the relay terminals. The elevator relay is mounted on the DIN rail. The terminals accept wire sizes from one number 18 AWG (1.0 mm²) wire to two number 12 AWG (4.0 mm²) wires. For connection to the screw terminal, strip the insulation back 3/8 inch (10 mm).

There are two types of relay coils (12 VDC and 24 VDC).

The relay has two sets of Form-C contacts that are rated for 5 amperes at 250 VAC (see Figure 3-12).

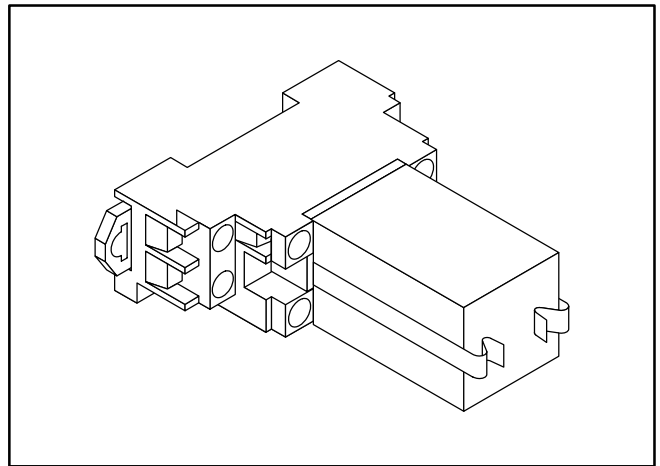

FIGURE 3-12. ELEVATOR RELAY

Manual Restore Option

The optional Manual Restore key switch (see Figure 3-13) is located on the front panel below the Control Panel.

When the switch is set to “Retransfer Inhibit,” the load remains connected to Source 2 after a transfer. When the switch is set to “Force Retransfer to Utility,” the load is transferred back to Utility power.

A manual restore input is set up by connecting a dry (voltage free) contact between P4-2 on the back of the control panel and TB1-7 and TB1-8 (see Figure 3-14). Closing the contact enables the feature and opening the contact disables it.

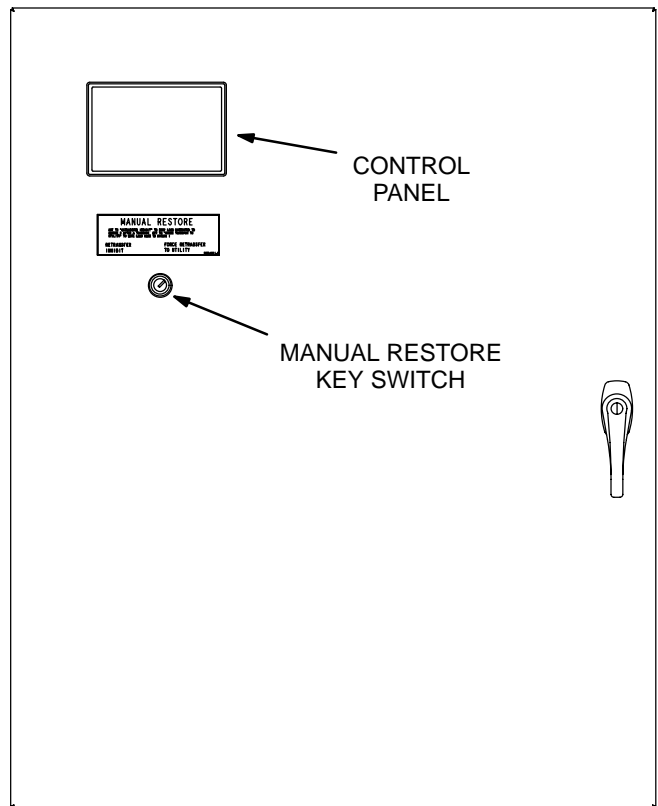

FIGURE 3-13. MANUAL RESTORE KEY SWITCH

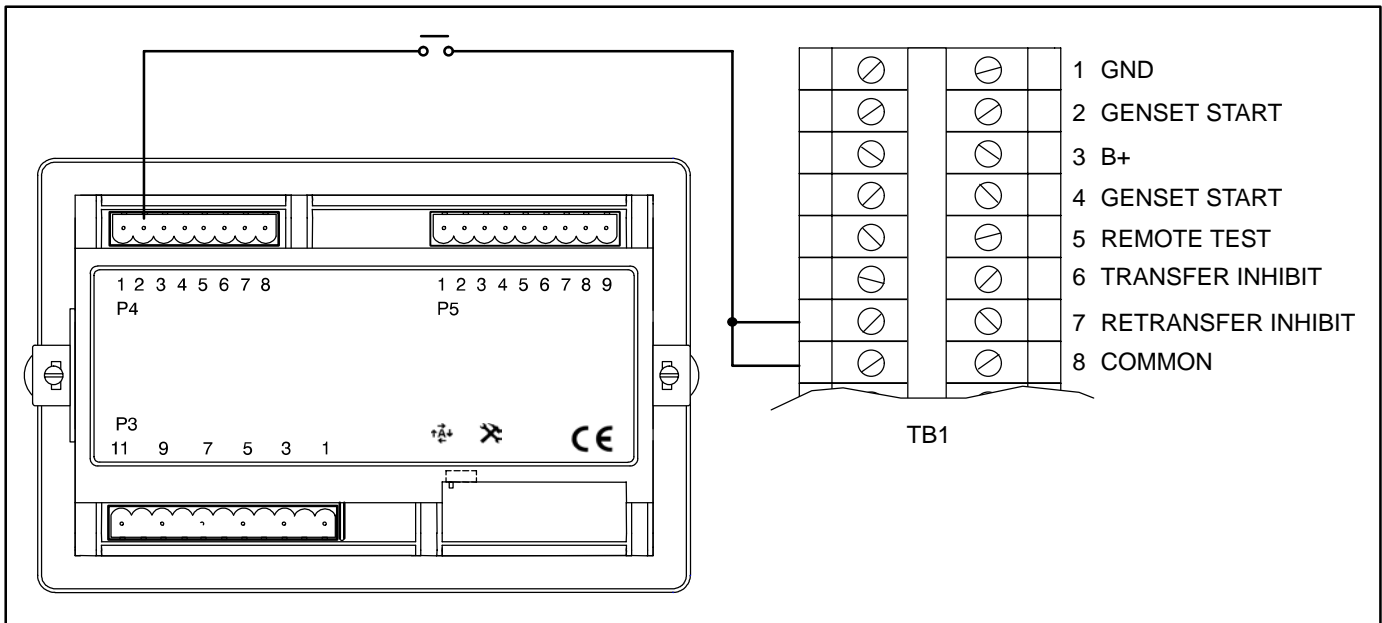

FIGURE 3-14. CONNECTIONS FOR MANUAL RESTORE INPUT

THIS PAGE LEFT INTENTIONALLY BLANK

4. Operation

TIME DELAYS

The transfer switch control uses various time delays to break from one power source and reconnect to the other source. The control panel can be used to adjust these time delays (see *Section 5*).

In the following descriptions of time delays, it is important to remember that:

- When the transfer switch is connected to Normal, it is connected to the utility power source.
- When the transfer switch is connected to Emergency, it is connected to the Genset power source.
- When the transfer switch is in the Neutral position, it is not connected to either power source.

Time Delay Engine Start (TDES)

This time delay prevents the generator from starting during brief utility power interruptions. This timer starts the instant the utility fails, as detected by the Undervoltage Sensor.

When the control senses a utility failure, the control starts the Time Delay Engine Start (TDES) timer. This time delay is configurable for 0 (disabled), 0.5, 1, 2, 3, 4, 6, or 10 seconds (default = 3 seconds).

If utility power returns while the TDES timer is active, the timer is reset. When the timer expires, the control de-energizes the start relay, closing the start contact signalling the generator to start. The timer is not reset until utility power returns. If the Override pushbutton is pressed or the Override input is grounded while the TDES timer is active, the TDES timer immediately expires.

Time Delay Engine Cooldown (TDEC)

This time delay allows the generator to cool down (under no load conditions) before the control turns it off.

The Time Delay Engine Cooldown (TDEC) starts timing when the load is retransferred to utility power. This time delay is configurable for 0 (disabled), 0.1,

5, 10, 15, 20, 25 or 30 minutes (default = 10 minutes).

When the TDES expires, the stop signal is sent to the generator and the timer is reset. Pressing the Override pushbutton or grounding the Override input has no effect on this time delay.

Time Delay Normal to Emergency (TDNE)

This time delay allows the generator to stabilize before the load is applied.

While connected to Normal, this time delay starts after utility power fails and the generator becomes available (the amber Genset Power Available LED is lit). This time delay also starts after the generator becomes available when a with load Test or Exercise period is activated.

The time delay is configurable for 0 (disabled), 1, 2, 3, 5, 30, 120, or 300 seconds (default = 5 seconds). If the generator fails any time during a TDNE, the control resets the timer and restarts it once the generator is again available.

If the Override pushbutton is pressed or the Override input is grounded while the TDNE timer is active, the TDNE timer immediately expires. The TDNE timer will not begin if a Transfer Inhibit input is active.

Time Delay Emergency to Normal (TDEN)

While connected to Emergency, this time delay allows utility power to stabilize before the retransfer command is issued. This delay also allows the generator to operate under load for a minimum amount of time before transferring back to utility power.

This time delay starts with the transfer switch connected to the generator and after the utility becomes available following an outage (The green Utility Power Available LED is lit). This time delay also starts when an active Test or Exercise period is ended. After the delay, the transfer switch can retransfer the load to the utility power source.

The time delay is configurable for 0 (disabled), 0.1, 5, 10, 15, 20, 25 or 30 minutes (default = 10 minutes). If the utility fails any time during this time delay, the control resets the timer and restarts it once utility power becomes available. If the genera-

tor fails at any time during this time delay, the timer expires and the normal retransfer sequence takes place.

If the Override pushbutton is pressed or the Override input is grounded while the TDEN timer is active, the TDEN timer immediately expires. The TDEN timer will not begin if a Retransfer Inhibit input is active.

Time Delay Programmed Transition (TDPT)

This feature causes the transfer switch to pause in the Neutral position for an adjustable period of time whenever there is a transfer from one source to another. The intentional delay allows the residual voltage of an inductive load to sufficiently decay before connecting it to another power source. This delay prevents potentially damaging voltage and current transients in the customer's power system. If TDPT is set to zero, then the transfer switch transfers from one source to the other with no neutral position delay.

The control activates a Program Transition Time Delay (TDPT) whenever the transfer switch has disconnected from one source and is in the Neutral position. The time delay is configurable for 0 (disabled), 0.5, 1, 2, 3, 4, 6 or 10 seconds (default = 0 seconds). The control also detects if the transfer switch has disconnected from the first source before connecting it to the second source.

If there is a power source failure while the TDPT is active, the control only transfers to the remaining active power source. The control does not terminate the TDPT timer if either source fails while the transfer switch is in the Neutral position.

Time Delay Elevator (TDEL) Pre-Transfer

Primarily used in elevator applications, this delay sets a time to wait for an elevator pre-transfer signal. This signal allows the elevator to come to a complete stop before the switch transfers.

The elevator pre-transfer signal and associated time delay, is used to signal an elevator control system that there is an impending transfer or retransfer

(i.e., the elevator is going to see a brief power failure).

This delay is disabled during an actual source failure. If the timer is set for more than 0 seconds, then the control activates the elevator pre-transfer output and time delay prior to transferring the transfer switch between two live sources. If the control is in a Test or Exercise sequence, the control adds an additional delay prior to activating the transfer and retransfer commands. After the TDNE (and/or TDEN) time delay expires, the control activates the Elevator output and starts the TDEL timer.

The output relay has two normally open and two normally closed contacts, rated 5 amps at 380 volts.

When the timer expires, the control issues the transfer (or retransfer) command. When the timer is inactive or expires, the control deactivates the relay output.

The Elevator Pre-transfer Time Delay is configurable for 0 (disabled), 1, 2, 3, 5, 30, 120, or 300 seconds (default = 0 seconds).

Transfer Inhibit and Retransfer Inhibit do NOT affect or delay the elevator pre-transfer delay while it is active.

The Override pushbutton or Override input has no effect on this time delay.

The GTEC control also includes a feature called Elevator Post Transfer Delay that keeps the elevator output active for the same TDEL time period after the transfer switch transfers. For more information, see "Elevator Post Transfer Delay" below.

Elevator Post Transfer Delay

The Elevator Post Transfer Delay feature keeps the elevator output active for the same TDEL time period after the transfer switch transfers. Instead of deactivating the elevator output when the pre-transfer time delay expires, the control keeps the output active and starts the TDEL timer again after it senses that the transfer switch has transferred. When the TDEL timer expires the second time, the control deactivates the elevator output. The Elevator Post Transfer Delay is configurable to be enabled (On) or disabled (Off) (default = Off).

MANUAL OPERATION

The transfer switch has an operator handle for manually transferring the load (see Figure 4-1). Manual operation must be performed by qualified personnel under **NO-LOAD CONDITIONS ONLY**. Use the following procedure:

⚠WARNING *Manual operation of the transfer switch under load presents a shock hazard that can cause severe personal injury or death. Do not attempt to operate the switch manually when it is under load. Disconnect both sources of power before operating manually.*

1. Verify that the transfer switch is not under load.
2. Open the cabinet door of the automatic transfer switch.
3. Remove power to the control by removing the FB fuse (see Figure 4-1).

4. To close Side A:

- a. Place the handle on the transmission shaft.
- b. Rotate it upwards until the switch locks.

To open either side (Side A or Side B):

- a. Remove the manual operation handle.

- b. Press the trip with a screwdriver.

To close Side B:

- a. Place the handle on the transmission shaft.
- b. Press and hold "Select" with a screwdriver while rotating the handle upwards until the switch locks.

NOTE: Remember that the transfer switch transfers the load to the active power source. (If both power sources are available, it transfers the load to the utility.)

⚠WARNING *If not removed, automatic transfer switch operation results in rapid movement of the manual operator handle and presents a hazard of severe personal injury. Remove the handle before switching back to automatic operation. Store the manual operation handle in a safe location (for example, the bottom of the cabinet).*

5. Make sure the manual operation handle is removed from the transmission shaft and stored in a safe location.
6. To return to automatic operation, restore power to the control by reinserting the FB fuse.
7. Close the cabinet door.

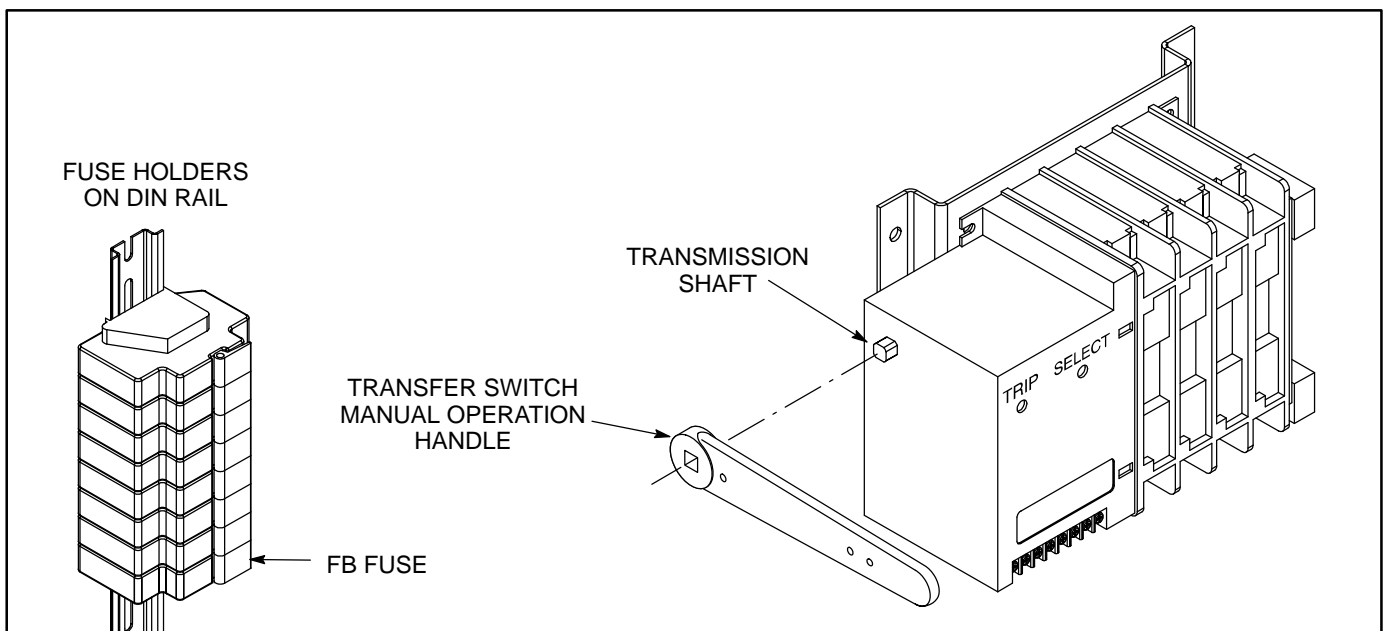

FIGURE 4-1. MANUAL OPERATION HANDLE

PUSHBUTTON OPERATION

The following describes operation of the three pushbuttons located on the control panel.

Test Pushbutton

The Test pushbutton is used to:

- Start a genset test. The Test LED flashes and stays on if the Test pushbutton is pressed and held for two seconds.
- Terminate a genset test. The Test LED flashes for two seconds and goes out if the Test pushbutton is momentarily pressed.

More information on testing is included on the following pages.

Override Pushbutton

The Override pushbutton is used to:

- Terminate the following system time delays:
 - Time Delay Engine Start (TDES)
 - Time Delay Normal to Emergency (TDNE)
 - Time Delay Emergency to Normal (TDEN)
- Bypass the TDNE timer and transfer the load immediately during an active Transfer Inhibit input.
- Bypass the TDEN timer and retransfer the load immediately during an active Retransfer Inhibit input.
- Stop the Utility Power Connected LED from flashing as a result of a failure to connect to

or disconnect from the utility when commanded.

- Stop the Genset Power Connected LED from flashing as a result of a failure to connect to or disconnect from the genset when commanded.
- Cancel an active exercise period.

The Program Transition (TDPT), Elevator signal (TDEL), and Engine Cool Down (TDEC) time delays are not affected by pressing this pushbutton.

Set Exercise Pushbutton

This pushbutton is only used with the integrated exerciser and only functions if the External Exercise function is disabled (set to Off). Information on configuring the control panel is included in *Section 5*.

The Set Exercise pushbutton is used to:

- Set a delayed repeat exercise period when the pushbutton is pressed and held for five seconds.
- Start an immediate exercise period (that also repeats) if the pushbutton is pressed momentarily within ten seconds of starting the delayed exercise period.
- Cancel a repeatable exercise period if the pushbutton is pressed and held for five seconds.

More information on using the integrated exerciser is included on page 4-8.

TEST WITH OR WITHOUT LOAD

This feature allows a transfer switch operator to test the transfer switch and generator power system. The test is configurable to be with load or without load. A test with load initiates a load transfer. A test without load just starts the generator and runs it without load.

1. Verify that the transfer switch is set to test with or without load, as desired (see *Section 5*).
2. To start a test, press and hold the Test Pushbutton for two seconds or ground the Remote Test input.
3. To end the test, momentarily press the Test pushbutton or remove the ground from the Remote Test input.

NOTE: When ending a test with load, you can bypass the retransfer time delay (TDEN) and cause the immediate load retransfer by pressing the Override button. The generator stops after the engine cooldown time delay (TDEC).

Test With Load Sequence of Events

The following describes the sequence of events of an GTEC transfer switch during a test with load. In this example, TDPT is set to zero, the phase check sensor is disabled, the Transfer Inhibit and Retransfer Inhibit inputs are inactive, and TDEL is set to zero.

The utility must be acceptable during the entire test event. Acceptability is determined by the active source sensor (undervoltage sensor). If, at any time, the undervoltage sensor determines that the utility is not acceptable, the Test is terminated.

Before a test can begin, the transfer switch must be connected to the utility power source and utility power must be available.

1. Verify that the transfer switch is set to test with load.
2. Verify that the green Utility Power Connected LED on the control panel is lit.

3. Verify that the green Utility Power Available LED on the control panel is lit.
4. Press and hold the control panel Test pushbutton for two seconds or ground the Remote Test input to initiate the Test. The Test LED flashes two times per second for two seconds, acknowledging that the test was activated. Once the test period starts, the Test LED stays on continuously.
5. The control simulates a utility power failure but the Utility Power Available LED remains lit as long as the utility is still available.
6. The control starts the TDES timer. After the timer expires, the control de-energizes the start relay, closing the start contact to signal the generator to start.
7. When the generator output is acceptable (the Genset Power Available LED is lit) the control starts the TDNE timer.
8. After the TDNE timer expires, the transfer switch transfers to the genset (the Genset Power Connected LED is lit).
9. The control continues to run the generator with the transfer switch connected to the genset until the control panel Test pushbutton is momentarily pressed or the ground is removed from the Remote Test input.
10. After this action, the control starts the TDEN timer. The Test LED flashes twice per second for two seconds to acknowledge the operation and then the Test LED goes out.
11. After the TDEN timer expires, the transfer switch retransfers back to the utility (the Utility Power Connected LED is lit).
12. Once the transfer switch is connected to utility power, the control starts the TDEC timer.
13. After the timer expires, the control energizes the start relay, opening the start contact to signal the generator to stop.

Test Without Load Sequence of Events

The following describes the sequence of events of a GTEC transfer switch during a test without load. In this sequence of events, the generator is started and runs without load for the duration of the test.

The utility must be acceptable during the entire test event. Acceptability is determined by the active source sensor (undervoltage sensor). If, at any time, the undervoltage sensor determines that the utility is not acceptable, the Test is terminated.

Before a test can begin, the transfer switch must be connected to the utility and utility power must be available.

1. Verify that the transfer switch is set to test without load.
2. Verify that the green Utility Power Connected LED on the control panel is lit.
3. Verify that the green Utility Power Available LED on the control panel is lit.
4. Press and hold the control panel Test pushbutton for two seconds or ground the Remote Test input. The Test LED flashes twice per second for two seconds acknowledging that the test was activated. Once the test period starts, the Test LED stays on continuously.
5. The control de-energizes the start relay, closing the start contact to signal the generator to start. When the genset starts and produces power, the amber Genset Power Available LED lights.
6. The control continues to run the generator without load until the control panel Test pushbutton is momentarily pressed or the ground is removed from the Remote Test input.
7. After the control panel Test pushbutton is momentarily pressed or the ground is removed from the Remote Test input, the control flashes the Test LED twice per second for two seconds to acknowledge the operation and then goes out.
8. The control energizes the start relay, opening the start contact to signal the generator to stop.

SENSORS

Utility Sensor

The utility sensor monitors all phases of the utility for undervoltage conditions. Both the pickup and dropout set points are adjustable. The set points are listed in Table 4-1. Refer to *Section 5* for information on how to make adjustments.

TABLE 4-1. UTILITY UNDERVOLTAGE SET POINTS

Description	Available Set Points
Undervoltage Pickup (% of Nominal)	95%
	90%
Undervoltage Dropout (% of Nominal)	90%
	85%
	80%
	70%

NOTE: If the utility undervoltage pickup is set at 90%, then the dropout has to be set lower than 90%.

Figure 4-2 illustrates how the pickup and dropout settings work.

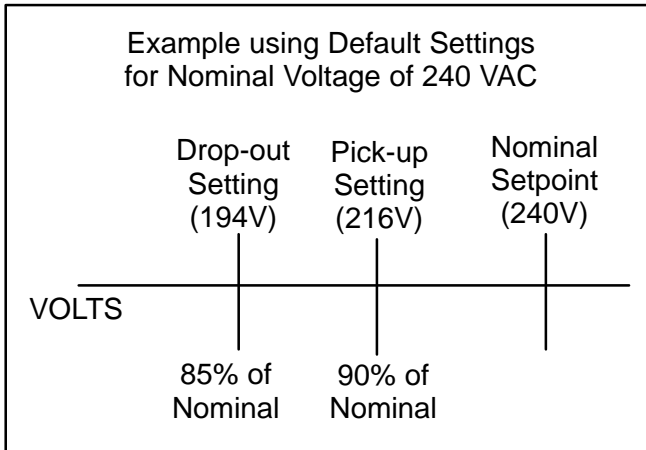

FIGURE 4-2. UNDERVOLTAGE SENSING

Generator Sensor

The generator sensor is a single phase sensor that monitors undervoltage and underfrequency condi-

tions. All the pickup and dropout settings are fixed and are not adjustable. The genset undervoltage and underfrequency set points are listed in Table 4-2.

TABLE 4-2. GENSET UNDERVOLTAGE AND UNDERFREQUENCY SET POINTS

Description	Set Point
Undervoltage Pickup (% of Nominal)	90%
Undervoltage Dropout (% of Nominal)	75%
Underfrequency Pickup (% of Nominal)	90%
Underfrequency Dropout (% of Nominal)	85%

Phase Check Sensor

The phase check sensor can be enabled (set to On) for applications that require a fast transfer of a load between two live sources (both power source available LEDs are lit). The phase check sensor determines when the relative phase difference (less than 25 degrees and approaching 0) and the frequency difference (less than 1 Hz) of the two sources are within specified limits. When all conditions are met, a transfer is initiated. If enabled, the phase check sensor is activated after all time delays have expired, just before the transfer switch transfers the load, and only when both sources are available. Information on configuring the Phase Check On/Off function is included in *Section 5*.

Return to Programmed Transition

This feature can be used in conjunction with the phase check sensor. If, for some reason the two sources do not fall within the specified limits of the phase check sensor for a period of two minutes, then the control bypasses the phase check sensor, returns to the Programmed Transition sequence of operation, and transfers the load. If this feature is enabled, the programmed transition time delay (TDPT) should be set greater than zero. The actual setting depends on your load.

GENERATOR SET EXERCISER

Run the generator at least once each week with at least 50 percent load (if possible). If you do not want to use the exerciser, use the Test pushbutton, as described earlier in this section, to test the generator set each week.

The control panel includes an integrated exerciser that is set by pressing the Set Exercise pushbutton. In addition, there may also be an optional fully programmable external exerciser clock installed and wired to a control input (see page 4-10).

If both types of exercisers are available, only one exerciser can operate at a time. The control panel must be configured for the type of exerciser being used. This is done by setting the External Exerciser function On or Off. If the integrated exerciser is used, the External Exercise On/Off function must be set to Off. If the external exerciser is used, the External Exercise On/Off function must be set to On. If the external exerciser is factory supplied, the External Exercise On/Off function is set to On at the factory. If the external exerciser is not factory installed, the External Exercise On/Off function is set to Off. Information on configuring the control is included in *Section 5*. Information on the optional external exerciser is included later in this section.

Exercise With or Without Load

The exercise with/without load configuration works with both types of exercisers (default = without load) – see *Section 5*. When “With Load” is selected, the load is transferred to the genset. When “Without Load” is selected, the genset runs with no load for the duration of the exercise period.

Integrated Exerciser

This function is standard and is built into the control. With this exerciser, the exercise period is 20 minutes and it repeats every 7, 14, 21, or 28 days (default = 7 days) – see *Section 5*.

The integrated exercise function cannot be used unless the External Exercise function is disabled (set to Off).

Before an exercise can begin, the transfer switch must be connected to utility power and utility power must be available (the green Utility Power Available LED must be lit).

Power Loss Backup

If DC power is removed from the control panel, the exercise clock uses a replaceable lithium battery (part number 416–1250) to back up the time setting. The battery is good for ten years and doesn’t need to be serviced. The battery is attached to the time chip on the control board.

If no exercise period is set, the Exercise LED is off (see Figure 3-4).

Setting the Integrated Exercise Period

1. Verify that the Exercise LED is off and the External Exercise function is disabled (set to Off – see *Section 5*). If the External Exercise function is enabled, the integral exerciser is disabled.
2. To set the exercise start time for a **repeat exercise period**, press and hold the Set Exercise pushbutton for 5 seconds. The Exercise LED flashes at a rate of twice per second for 5 seconds and then stays on when the exercise period is set. A delayed 20 minute exercise period will start in 12 hours. At that time, the Exercise LED flashes at a rate of once per second during the entire exercise period. When the exercise period is over, the Exercise LED quits flashing and remains on to signify that repeat exercise periods are enabled.
3. To start an **immediate exercise period** and have it repeat, momentarily press the Set Exercise pushbutton a second time within ten seconds of starting the delayed exercise period. Momentarily pressing and releasing the Set Exercise pushbutton a second time starts an immediate 20 minute exercise period instead of waiting for 12 hours. The Exercise LED flashes at a rate of once per second during the entire exercise period. When the exercise period is over, the Exercise LED stops flashing and remains on to signify that repeat exercise periods are enabled.

Canceling Repeat Exercise Periods

With the control panel Exercise LED on steady, press and hold the Set Exercise pushbutton for 5 seconds. The Exercise LED flashes at a rate of twice per second for 5 seconds and then goes out to signify that repeat exercise periods are cancelled.

Canceling An Active Exercise Period

Active exercise periods can be canceled by pressing the Override pushbutton on the control panel or by grounding the remote override input (P4-2) on the back of the control panel.

Power Source Failure During An Active Exercise Period

If either power source fails during an active exercise period, the control immediately terminates the exercise and proceeds with the automatic mode of operation.

Exercise Without Load Sequence of Events

1. When an exercise period becomes active, the Exerciser LED flashes at a rate of once per second.
2. The control signals the generator to start and run for 20 minutes.
3. After the exercise period has ended, the control signals the generator to stop.

4. The Exercise LED stops flashing and remains on to signify that repeat exercise periods are set (unless there are no repeat exercise periods). If there are no repeat exercise periods, the Exercise LED goes out.

Exercise With Load Sequence of Events

1. When an exercise period becomes active, the Exerciser LED flashes at a rate of once per second.
2. The control signals the generator to start.
3. When the generator output is acceptable, the control transfers the load to the generator, following the configuration set points.
4. After the exercise period has ended, the control retransfers the load back to the utility, following the configured set points.
5. Once the load is connected to utility power, the control runs the genset unload for the duration of the cooldown timer (TDEC).
6. After the TDEC timer expires, the control signals the genset to stop.
7. Unless the repeat exercise periods have been canceled, the Exercise LED quits flashing and remains on to signify that repeat exercise periods are set. If the exerciser is not set up to repeat exercises, the Exercise LED goes out.

OPTIONAL EXTERNAL EXERCISER

The optional external exercise clock is a 7-day, 24-hour clock that, when installed, can store and execute several start/stop programs per day and repeat exercise periods every week. It can be programmed to run exercise periods at different times on different days. Unlike the integrated exerciser, the external exercise can schedule an exercise period for something other than 20 minutes.

If the External Exercise function is enabled (set to On), then the integrated exerciser is disabled.

NOTE: After a period of inactivity, the clock enters sleep mode and turns off the display. To reactivate the display, briefly press the Menu button.

Up to 28 programs are available to set exercise start and stop times. One program is required to start an exercise period and a second one is required to stop an exercise period.

The exerciser clock also has a built-in test feature that can be used to initiate a genset start and run cycle.

The exerciser clock contains a lithium battery that is used as a backup power source. The battery is not

replaceable. When the clock is running off the internal battery, three flashing dots are displayed between the hour and minute values (see Figure 4-3). Unless the clock battery fails, exercise programs are stored and are not lost during a power outage.

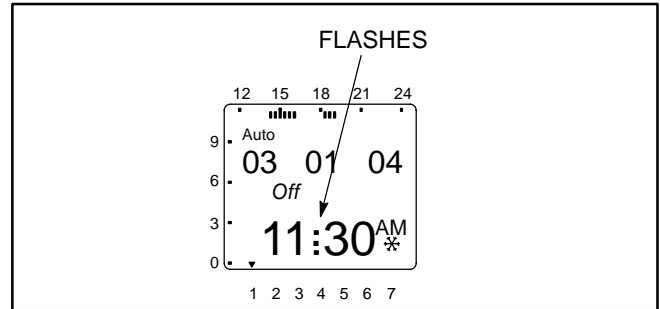

FIGURE 4-3. INDICATOR OF CLOCK RUNNING OFF THE INTERNAL BATTERY

Figure 4-4 illustrates the face of the exercise clock and provides information on the display and the function of the buttons.

Exercise With or Without Load

The external exercise clock does not include an exercise with or without load function. This function must be configured using the transfer switch control panel. For more information, see *Section 5*.

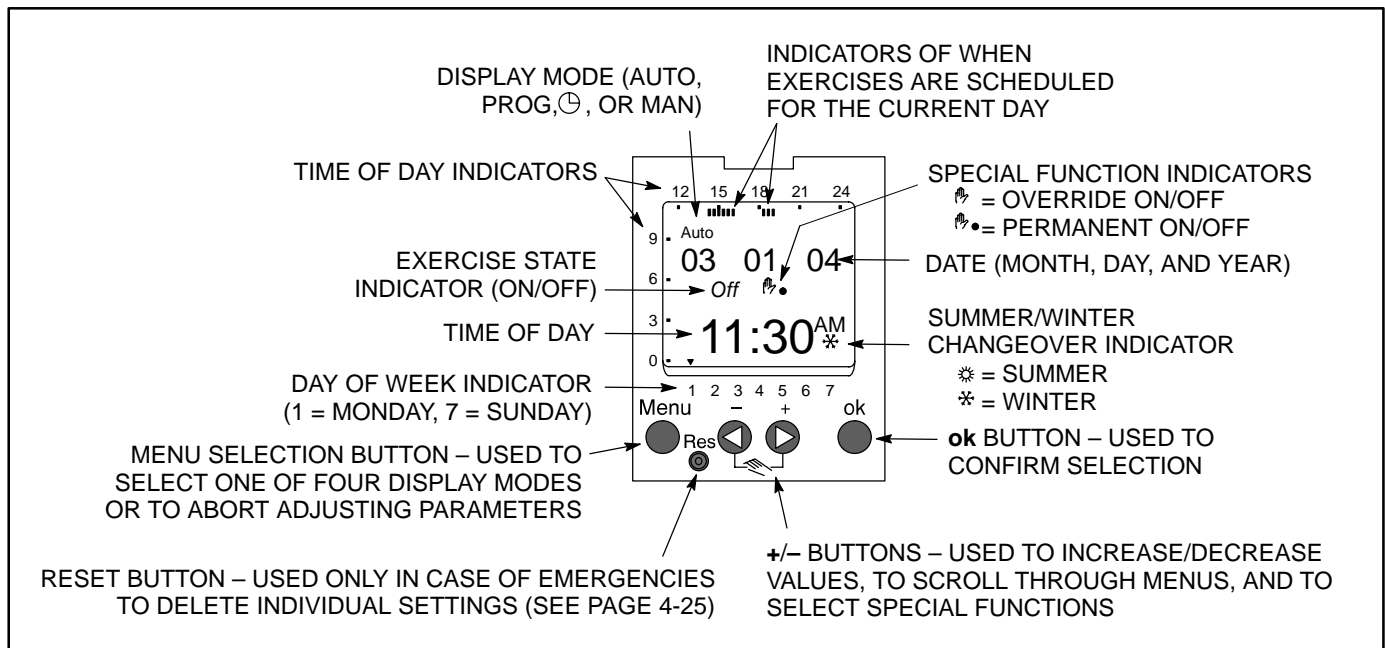

FIGURE 4-4. EXERCISE CLOCK FEATURES

Using the Menu Button

The Menu selection button is used to select three display modes that have adjustable menus.

- The Clock mode (☉) is used to set the correct date and time. This mode can also be used to automatically switch to the correct summer/winter time. See page 4-11.
- The Program mode (Prog) is used to set (see page 4-14), review (see page 4-17), and clear exercise start/stop times (see pages 4-20 and 4-21).
- The Manual mode (Man) is used to enter a 4-digit code to prevent changing settings by unauthorized personnel. See page 4-24.

When adjustments are completed, the Home menu (Auto mode) is redisplayed (see Figure 4-4). The Menu button can also be used to abort adjusting parameters and return to the Home menu.

Using the +/- Buttons

Pressing the + or – button is used to:

- Increase or decrease a parameter in an adjustable menu
- Select the next or previous menu.

Simultaneously pressing the + and – buttons is used to select special functions.

- Initiate an exercise (see page 4-22)
- Override an active exercise (see page 4-22)
- Select permanent on/off mode (see page 4-23)

Using the ok Button

The **ok** button is used to confirm the menu selection or program adjustments you have made. Upon pressing the **ok** button, the next available menu is displayed and, if any program adjustments were made, the changes are saved.

Setting the Clock with Summer/Winter Time (Daylight Savings Time)

The clock is programmed with the correct date and central USA standard time and with the correct daylight savings time settings. If it is necessary to change these settings, the following describes how to adjust the time and date and how to set the clock to automatically switch to summer/winter time (daylight savings time).

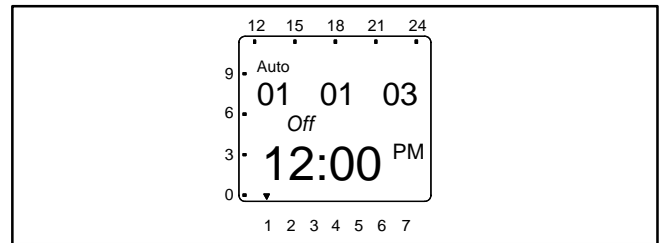

1. Press the Menu button on the exercise clock. The Program menu is displayed.

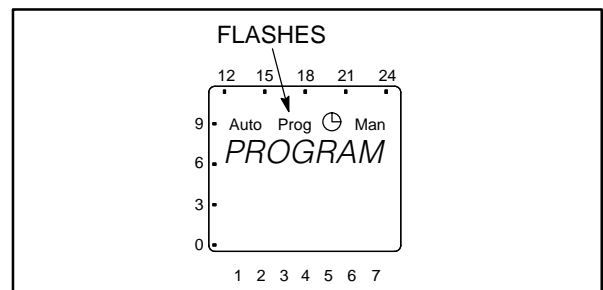

2. Press the + button. The Date/Time menu is displayed.

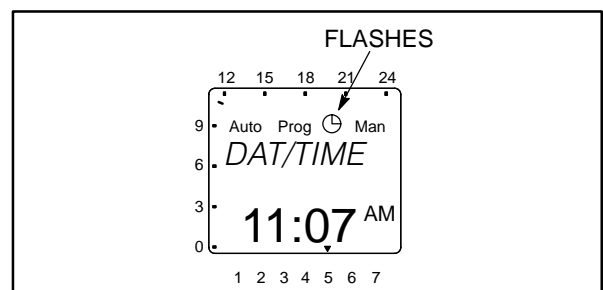

3. Press the **ok** button to display the Year menu.

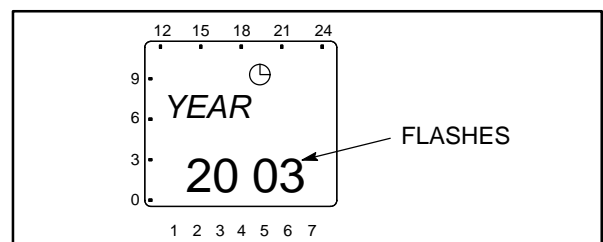

4. Press the **+** or **-** button to set the correct year.
Press the **ok** button to display the Month menu.

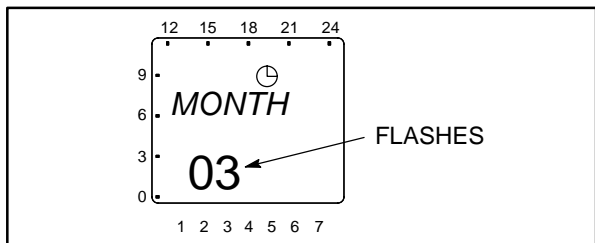

5. Press the **+** or **-** button to set the correct month.
Press the **ok** button to display the Day menu.

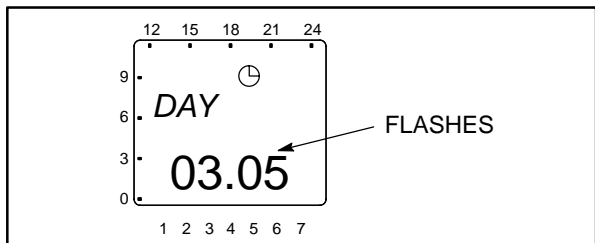

6. Press the **+** or **-** button to set the correct day.
Press the **ok** button to display the Hour menu.
A small triangle is displayed above the assigned number in the display for the day of the week (1 = Monday, 7 = Sunday).

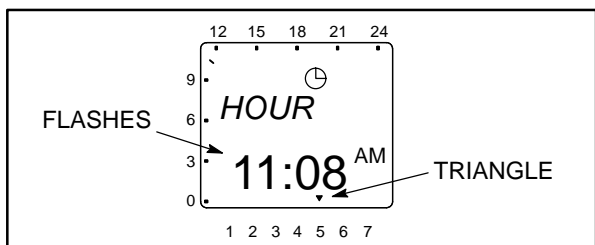

7. Press the **+** or **-** button to set the correct hour.
A line is displayed on the screen indicating the hour of the day selected (the left side of the screen is for the first half of the day [AM] and the top of the screen is for the second half of the day [PM]). Press the **ok** button to display the Minute menu.

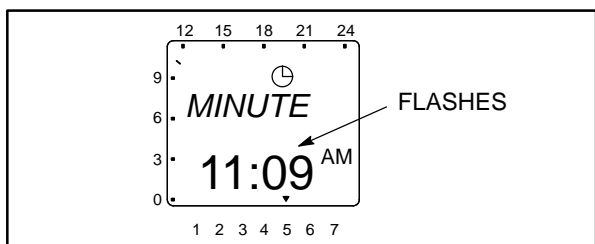

8. Press the **+** or **-** button to set the correct minute.
Press the **ok** button to display the Summer/Winter menu.

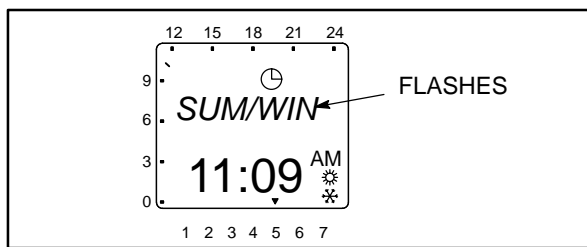

- NOTE:** If you do not wish to set the clock for automatic summer/winter changeover at this time, press the **+** or **-** button. "End" is displayed on the screen. Press the **ok** button to return to the Home menu.

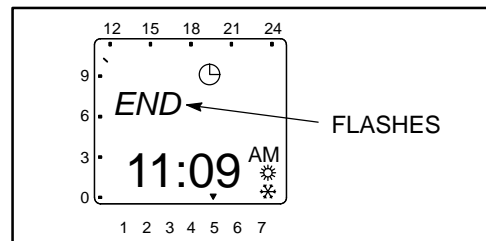

9. Press the **ok** button to display the No Summer/Winter menu.

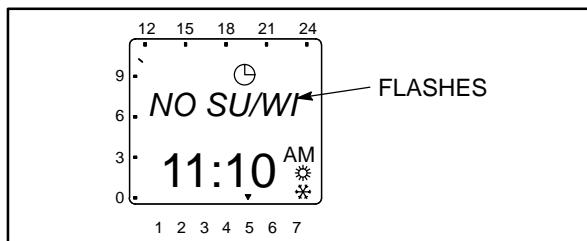

10. Press the **+** or **-** button to display the With Summer/Winter menu.

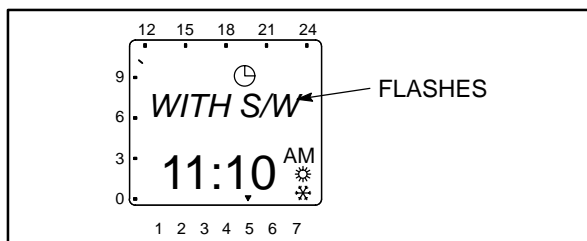

11. Press the **ok** button to display the World Area menu.

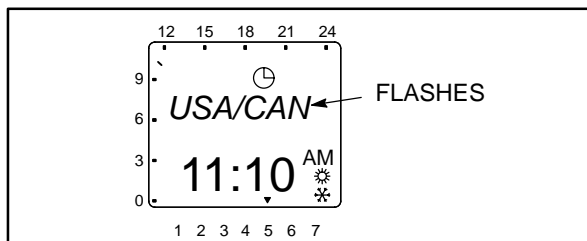

12. Either select one of the world areas that has been programmed for automatic time correction or else set up your own changeover times.

NOTE: With the Daylight Savings Time program set for North America,

- The first Sunday in April moves the time forward one hour.
- The last Sunday in October moves the time back one hour.

– If you wish to select one of the world areas (Europe, GP/P, SF/GR/TR, USA/CAN) that has been programmed for automatic time correction, press the + or – buttons until the correct world area is selected. Go to step 19.

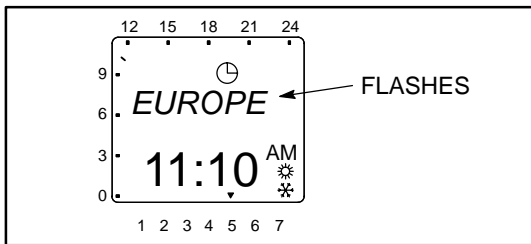

– If you wish to set up your own changeover times, continue with step 13.

13. To set up your own changeover times, press the + or – buttons from the World Area menu until the word “Free” is displayed.

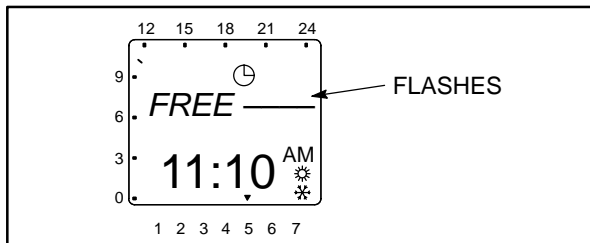

14. Press the **ok** button to display the menu for setting the month when the Summer changeover will take place. Press the + or – buttons until the desired month is displayed.

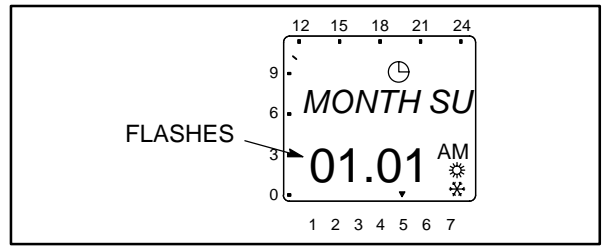

15. Press the **ok** button to display the menu for setting the week when the Summer changeover will take place. Press the + or – buttons until the desired week (1 thru 5 [1 = first week, 4 = fourth week, 5 = last week]) is displayed.

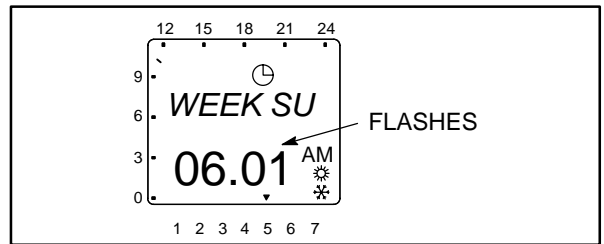

16. Press the **ok** button to display the menu for setting the hour of the day when the Summer changeover will take place. Press the + or – buttons until the desired hour (1 thru 3) is displayed.

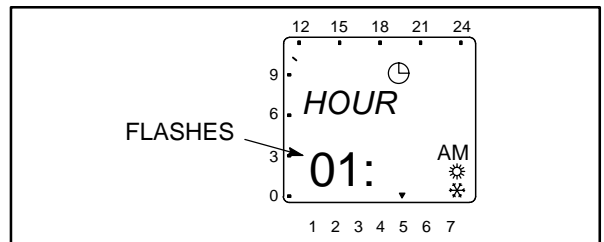

NOTE: The starting time can only be set for 1:00, 2:00, or 3:00 AM.

17. Press the **ok** button to display the menu for setting the month when the Winter changeover will take place. Press the + or – buttons until the desired month is displayed.

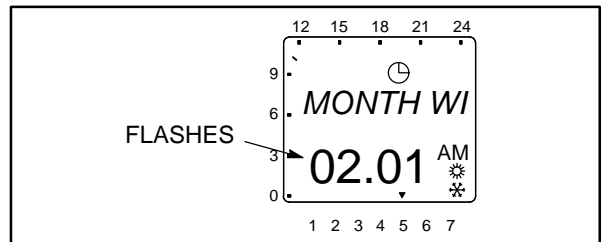

- Press the **ok** button to display the menu for setting the week when the Winter changeover will take place. Press the **+** or **-** buttons until the desired week (1 thru 5 [1 = first week, 4 = fourth week, 5 = last week]) is displayed.

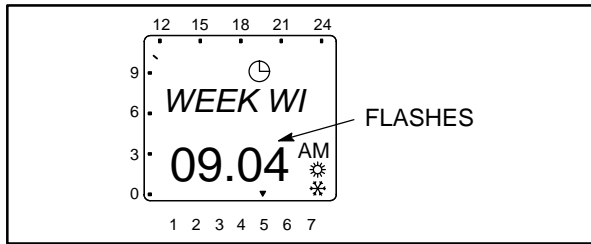

NOTE: The starting time for the winter changeover is the same time that was set in step 16.

- Press the **ok** button. The Home menu is redisplayed and the appropriate summer/winter symbol is displayed.

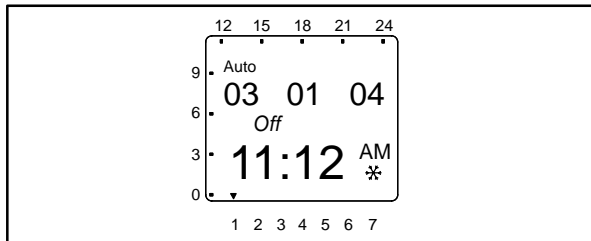

Setting Exercise Start and Stop Times

Up to 28 programs can be used to set exercise start and stop times. One program is required to start an exercise period and a second one is required to stop an exercise period.

NOTE: If the Menu button is pressed before a Start/Stop program is saved, the word "Escape" is displayed on the screen. The program settings are lost and the Home menu is displayed after two seconds or by pressing the **ok** button.

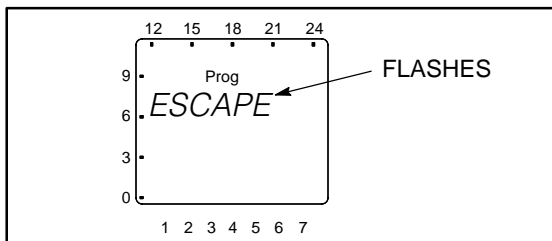

- From the Home menu, press the **Menu** button. The Program menu is displayed.

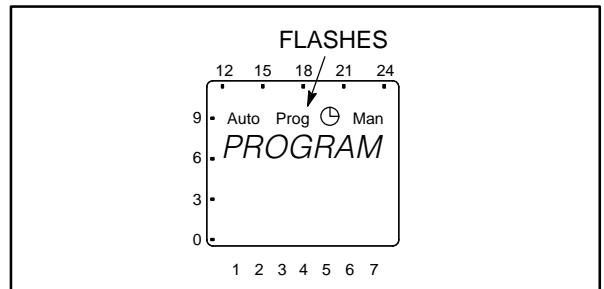

- Press the **ok** button. The New Program menu is displayed.

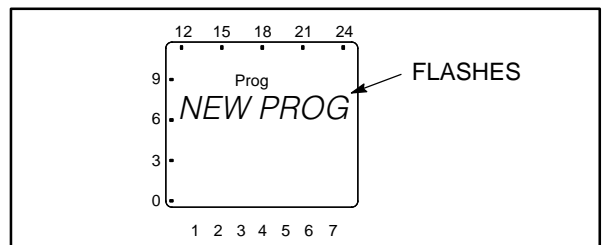

- Press the **ok** button. The number of available programmable time periods (maximum of 28) is temporarily displayed.

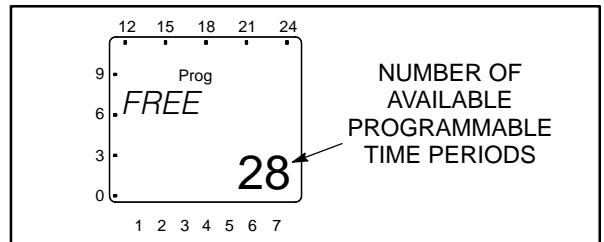

- The Starting Time (Time On) menu is displayed. Press the **ok** button.

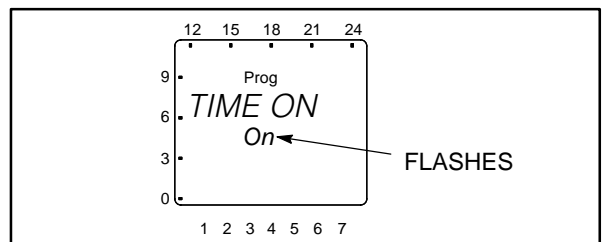

5. The Hour menu is displayed. Press the **+** or **-** buttons to set the desired exercise starting hour (default = 12:00 AM). A line is displayed on the screen indicating the hour of the day selected (the left side of the screen is for the first half of the day [AM] and the top of the screen is for the second half of the day [PM]). Press the **ok** button.

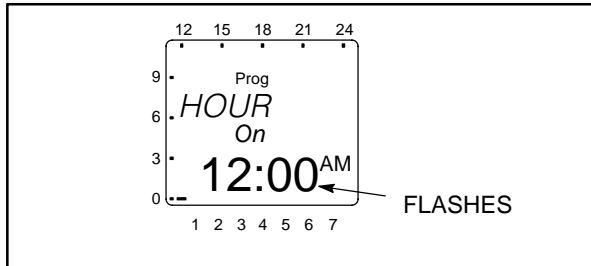

6. The Minute menu is displayed. Press the **+** or **-** buttons to set the desired exercise starting minute. Press the **ok** button.

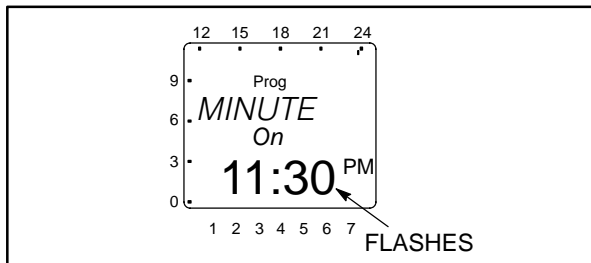

7. A menu is displayed for selecting the day of the week the exercise is to begin (default = Monday). Press the **+** or **-** buttons to select the desired day of the week. A small triangle is displayed above the assigned number in the display for the day of the week (1 = Monday, 7 = Sunday). Press the **ok** button.

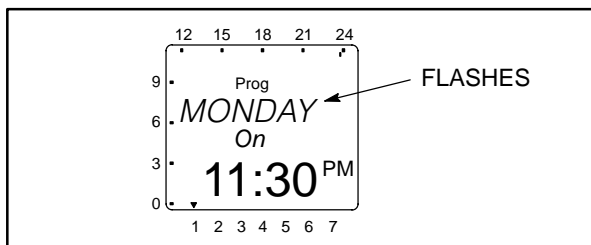

8. The Copy menu is displayed. If you do not wish to have the exercise repeat more than once a

week, go to step 9. If you do wish to have the exercise repeat more than once a week, go to step 10.

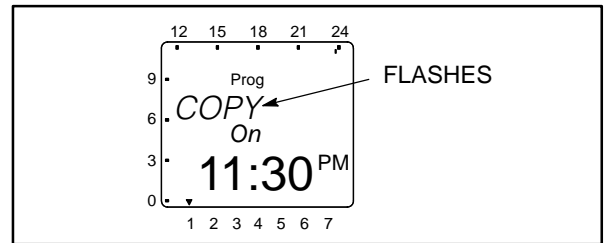

9. Press the **+** or **-** buttons. The Store menu is displayed. Press the **ok** button. Go to step 13.

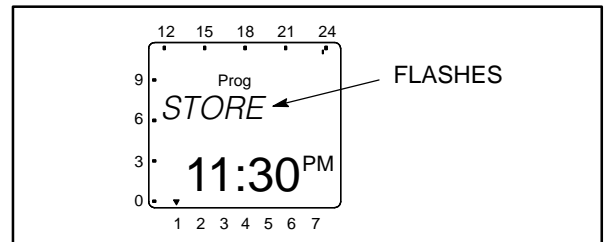

10. To repeat an exercise more than once a week, press the **ok** button when the Copy menu is displayed. The Add ___day menu is displayed. The day after the day selected in step 7 is displayed.

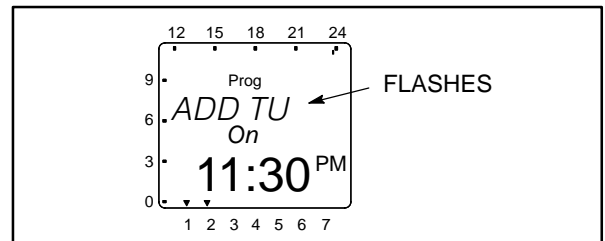

11. Press the **+** or **-** buttons to select the desired day of the week that an exercise is to begin. Press the **ok** button.

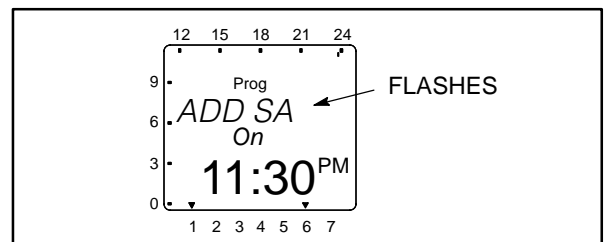

12. Press the **+** or **-** buttons. The Store menu is displayed. Press the **ok** button.

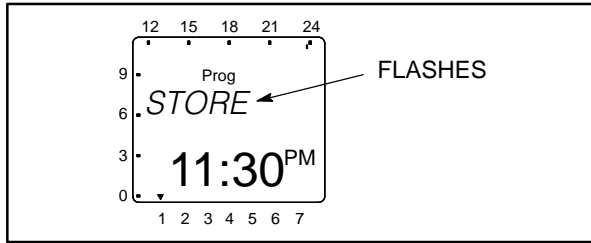

NOTE: After setting all days of the week that an exercise is to be repeated, you can use the **+** or **-** buttons to cycle through the days and recheck the programs. When a day that has a set program is redisplayed, it can be deleted. In the menu shown below, press the **ok** button to delete the displayed program.

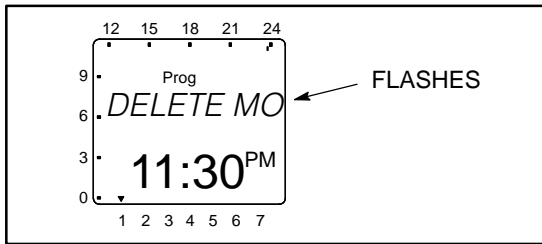

13. The New Program menu is redisplayed.

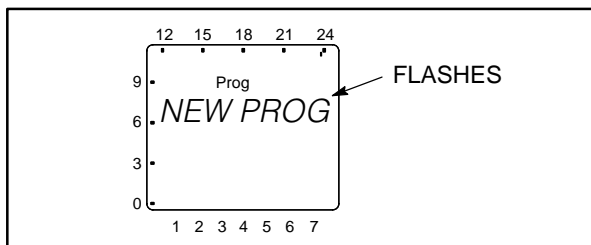

14. Press the **ok** button to enter a time the exercise is to end. The number of available programmable time periods is temporarily displayed. Please note that the number of available programmable time periods has now decreased by one.

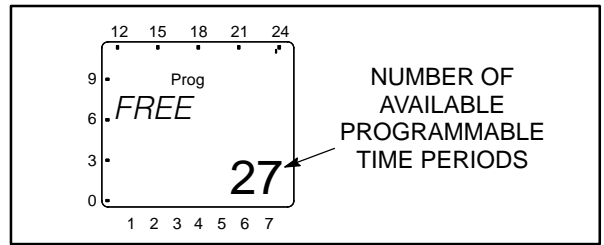

15. The Ending Time (Time Off) menu is displayed. Press the **ok** button.

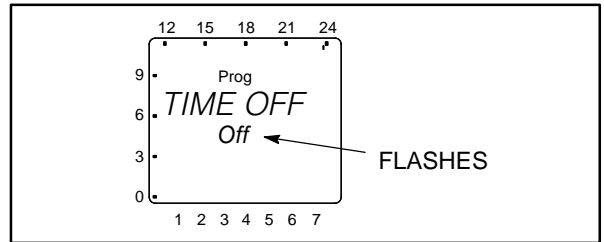

16. Repeat steps 5 thru 13 to set the stop time for your exercise.

17. When the New Program menu is redisplayed, press the **+** or **-** buttons until "End" is displayed.

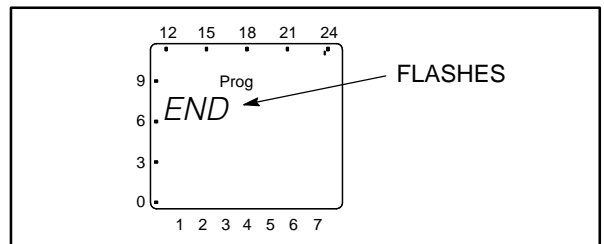

18. Press the **ok** button to return to the Home menu.

NOTE: If there are any exercises scheduled for the current day, those time periods are indicated on the screen.

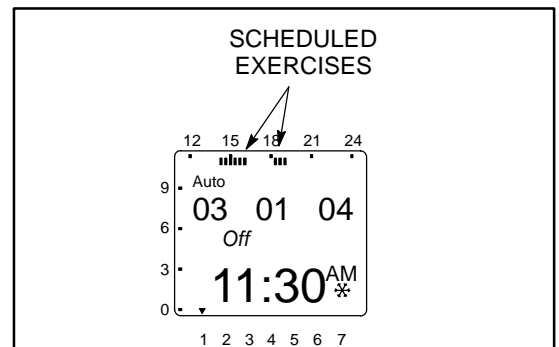

Checking the Programs

The Check Program menus can be used to review all set exercise start/stop times and, if necessary, delete them.

NOTE: If the Menu button is pressed while viewing start/stop programs, the Program Check function is aborted and the Home menu is redisplayed.

Reviewing Exercise Start/Stop Times

All exercise start and stop exercise parameters can be viewed from the Program Check menu. Normally, the starting time is followed by the ending time for a programmed exercise. However, if a second exercise period overlaps the time frame of the first exercise period in the current day, two start times are displayed, followed by two stop times.

- From the Home menu, press the **Menu** button. The Program menu is displayed.

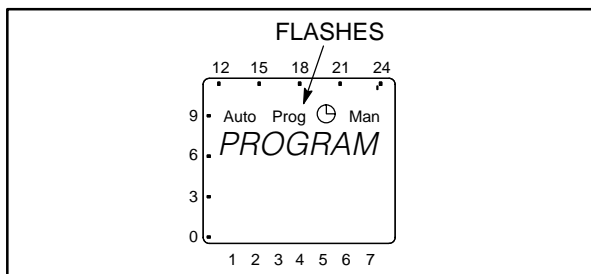

- Press the **ok** button. The New Program menu is displayed.

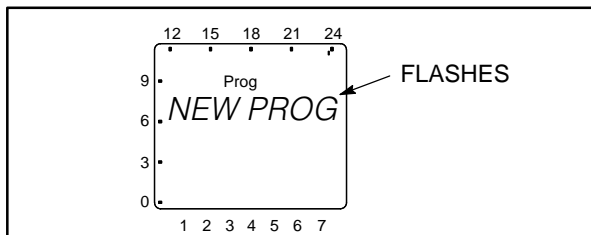

- Press the **+** button once. The Check menu is displayed.

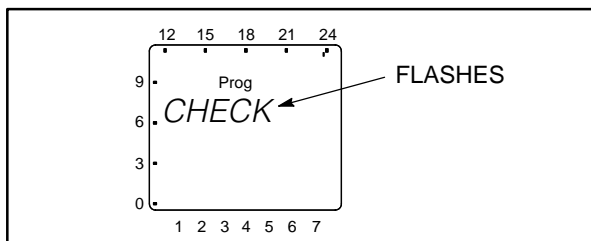

- Press the **ok** button. The Monday menu is displayed.

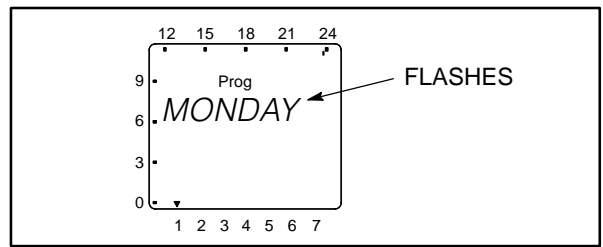

NOTE: If no exercise periods are set up, the message "Empty" is displayed. To return to the New Program menu, press the **ok** button.

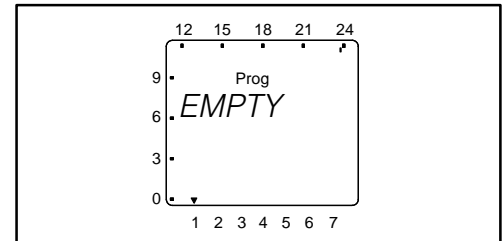

- Use the **+** or **-** buttons to select the day of the week you wish to check. Press the **ok** button. The starting time for the first exercise for the selected day is displayed.

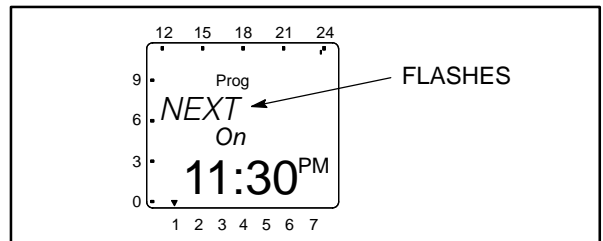

NOTE: If a day does not have any set exercise periods, the screen below is displayed.

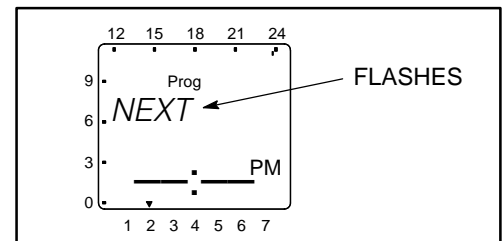

- Press the **ok** button. The ending time for the first exercise for the selected day is displayed.

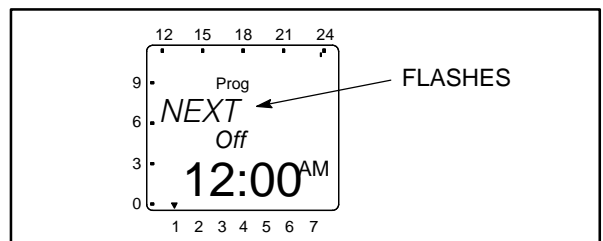

7. Press the **ok** button. The next exercise start time is displayed. If the next start time is not on the day selected in step 5, the day of the week is indicated on the bottom of the screen.

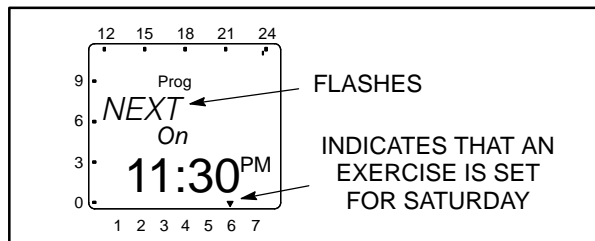

8. Review additional set exercise periods and return to the Main menu.

- To exit the Check Programs function without reviewing all set exercise periods, press the **+** or **-** buttons until “END” is displayed. Press the **ok** button to return to the Main menu.

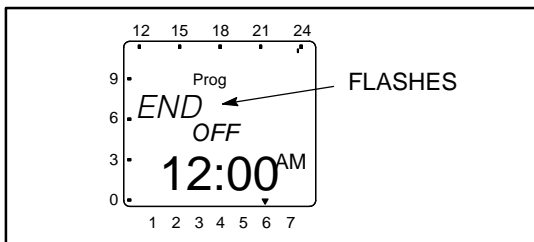

- To review all set exercise periods, repeat steps 6 and 7 until the word “END” is displayed.

played. Press the **ok** button to return to the Main menu.

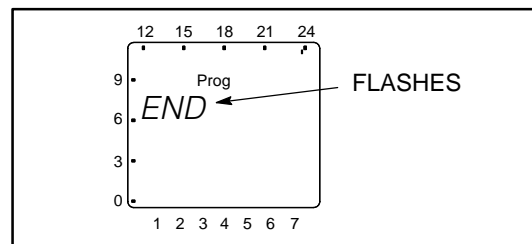

NOTE: If an exercise period has been programmed with a start time only, a continuous band of segments is displayed on the left side and top of the screen showing the time of day the incomplete exercise period is set to begin. This band of segments is also displayed on any other exercise periods scheduled for that day.

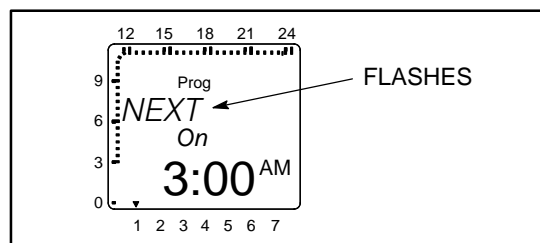

If an exercise period has been programmed with a stop time only, no special indicator is displayed. The stop time is simply ignored.

Deleting Exercise Start/Stop Times

While checking the programs, you can also delete individual start and stop times.

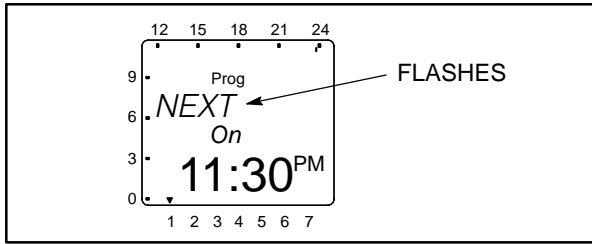

1. When an programmed exercise start time is displayed, press the **+** or **-** buttons until "Clear" is displayed.

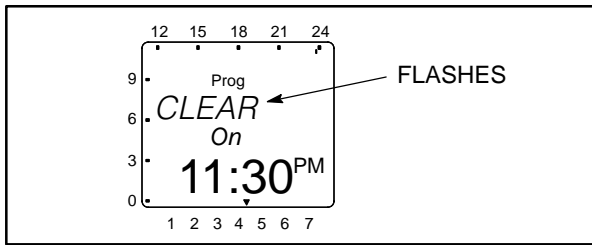

2. Press the **ok** button. The New Program menu is redisplayed.

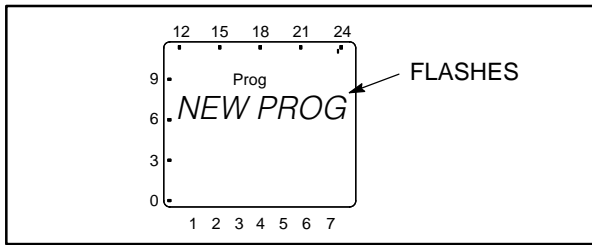

3. Press the **+** button once. The Check menu is displayed.

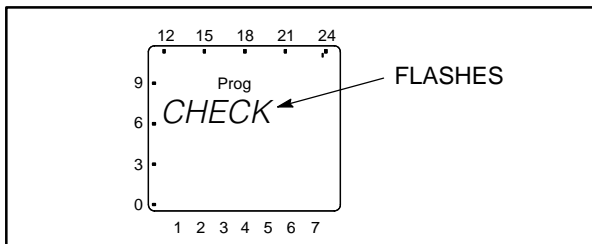

4. Press the **ok** button. The Monday menu is displayed.

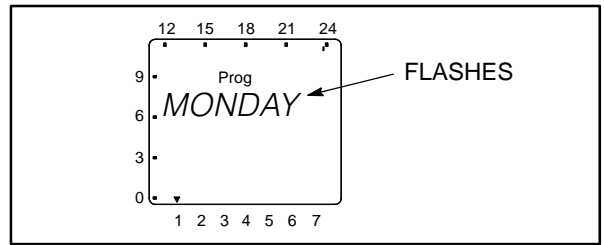

5. If necessary, use the **+** or **-** buttons to select the day of the week that includes the exercise ending time you wish to delete.

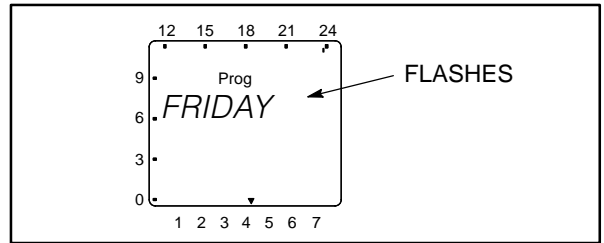

6. Press the **ok** button.

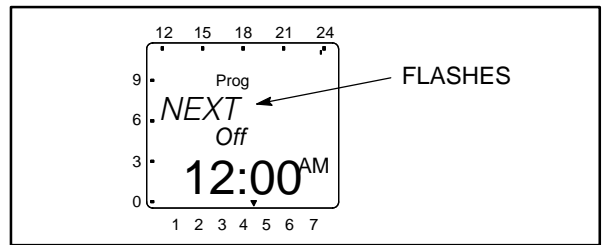

7. Press the **+** or **-** buttons until "Clear" is displayed.

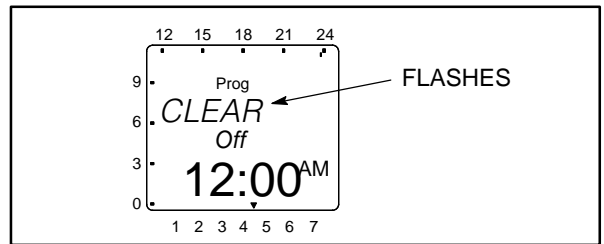

8. Press the **ok** button. The New Program menu is redisplayed.

Individual or all exercise periods can also be cleared. For more information, see "Erasing (Clearing) A Programmed Exercise Period" and "Erasing (Clearing) All Exercise Periods" below.

Erasing (Clearing) A Programmed Exercise Period

- From the Home menu, press the **Menu** button. The Program menu is displayed.

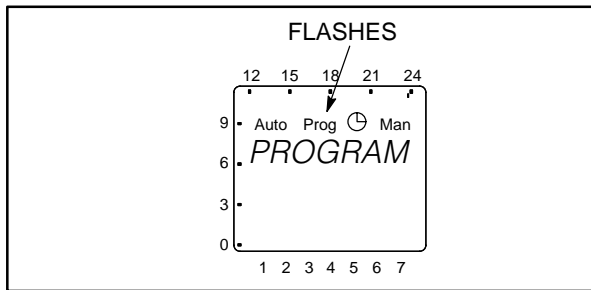

- Press the **ok** button. The New Program menu is displayed.

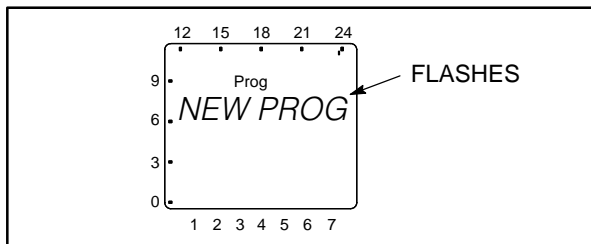

- Press the **+** or **-** button until the Clear menu is displayed.

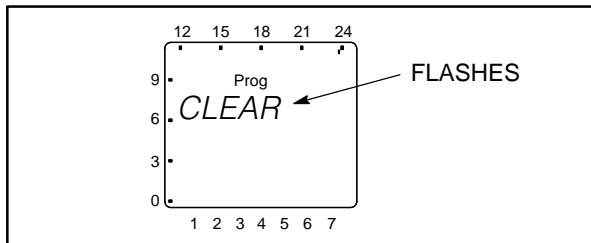

- Press the **+** or **-** button until "Single" is displayed.

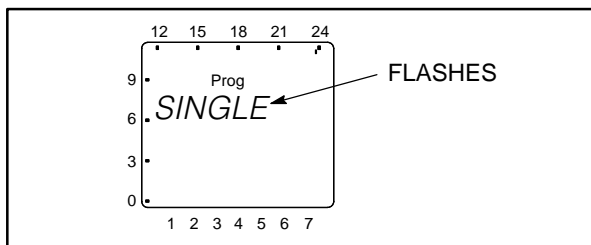

- Press the **ok** button. The first exercise start time of the week is displayed. To select a different exercise start time, press the **+** or **-** buttons until the desired time is displayed.

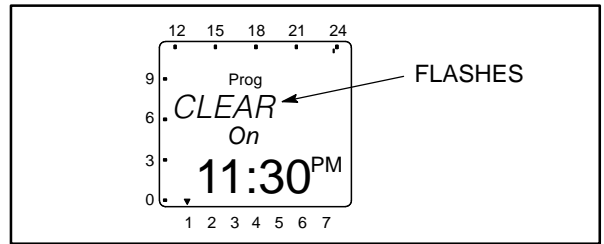

- Press the **ok** button. The New Program menu is redisplayed.

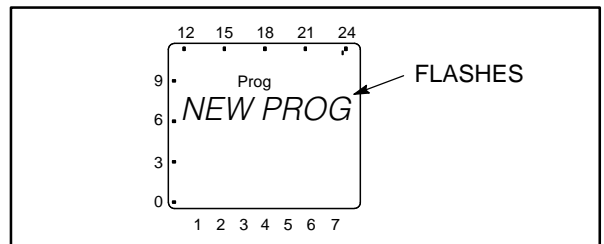

- Repeat steps 3 thru 6 to erase the stop time for the exercise period erased above.

- If necessary, repeat steps 3 thru 7 for any additional exercise periods that need to be erased.

- When the New Program menu is redisplayed, press the **+** or **-** buttons until the word "END" is displayed.

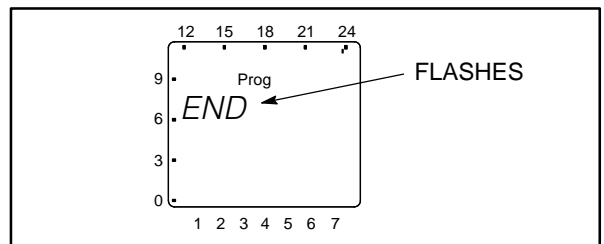

- Press the **ok** button to return to the Home menu.

Erasing (Clearing) All Programmed Exercise Periods

1. From the Home menu, press the **Menu** button. The Program menu is displayed.

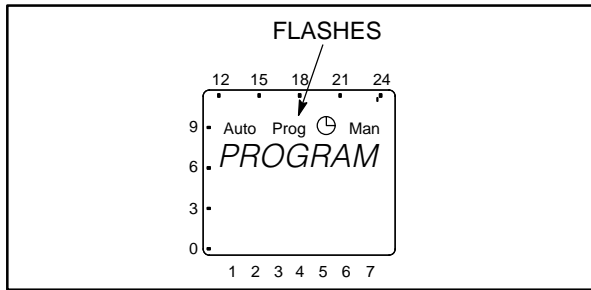

2. Press the **ok** button. The New Program menu is displayed.

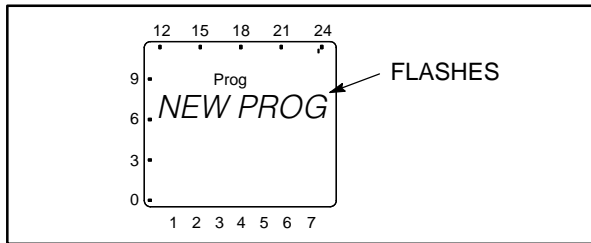

3. Press the **+** or **-** buttons until the Clear menu is displayed.

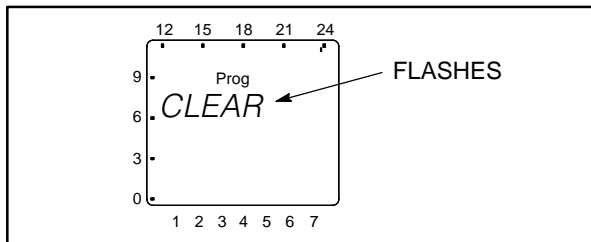

4. To clear all set exercise periods, press the **+** or **-** buttons until "All" is displayed. Press the **ok** button.

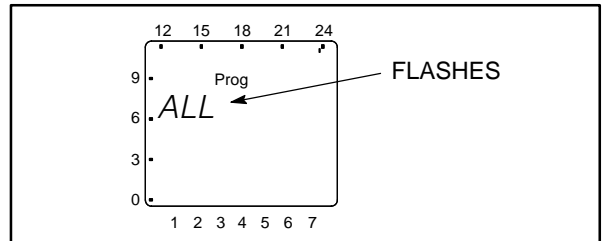

5. The word "Confirm" is displayed. To continue clearing all exercise programs, press the **ok** button. To abort clearing all exercise programs, press the **+** or **-** buttons.

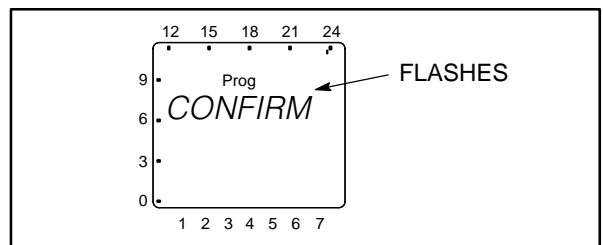

6. The new program menu is redisplayed. Press the **+** or **-** buttons until the word "END" is displayed.

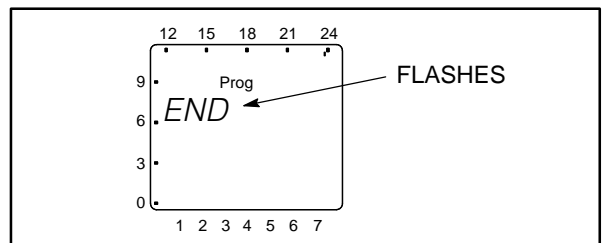

7. Press the **ok** button to return to the Home menu.

Initiating or Overriding an Exercise Program

The exercise clock has a built-in test feature that can be used to initiate an exercise that hasn't been programmed or cancel a programmed exercise in process.

The control panel Load/No Load function can be set to test the genset with or without load, as desired.

Initiating an Exercise

In the example shown below, "Off" indicates that no exercise is currently active.

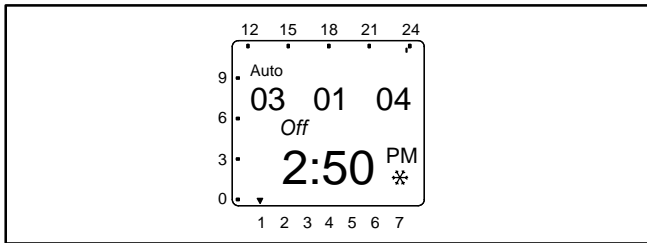

1. With the Home menu displayed, simultaneously press the + and – buttons for approximately one second. "Override" and a hand symbol  are displayed on the screen. In addition, "Off" is switched to "On" and the exercise is initiated.

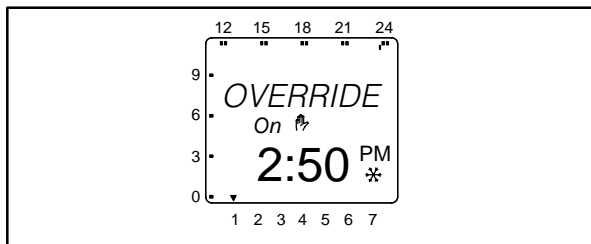

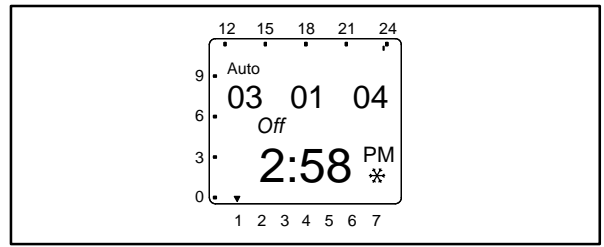

2. To end the exercise, simultaneously press the + and – buttons for approximately one second. The original Home menu is redisplayed and "On" is switched back to "Off."

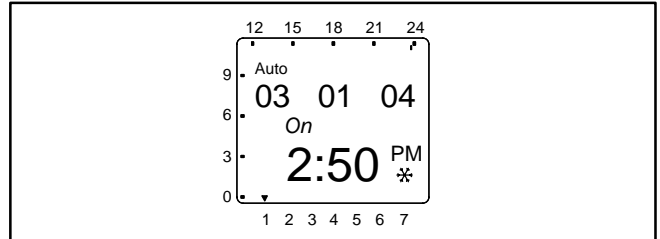

Overriding an Exercise

In the example shown below, "On" indicates that an exercise is currently active.



1. With the Home menu displayed, simultaneously press the + and – buttons for approximately one second. "Override" and a hand symbol  are displayed on the screen. In addition, "On" is switched to "Off" and the exercise is stopped.

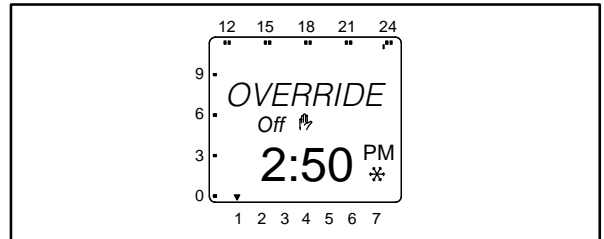

2. To restart the exercise, simultaneously press the + and – buttons for approximately one second. The original Home menu is redisplayed and "Off" is switched back to "On."

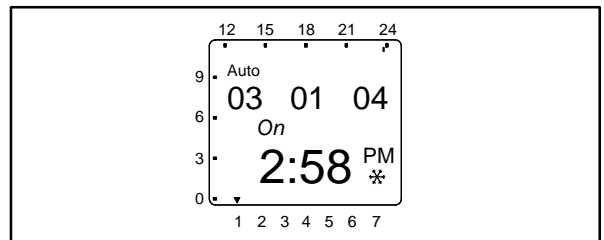

Selecting Permanent On/Off Mode

The exercise clock has a permanent on/off mode feature.

Selecting Permanent On/Off Mode Without an Active Exercise

In the example shown below, “Off” indicates that no exercise is currently active.

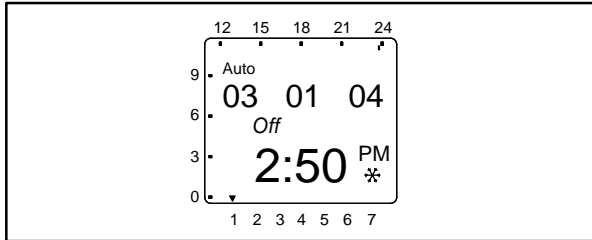

1. With the Home menu displayed, simultaneously press the + and – buttons for approximately two seconds. The Override menu is first displayed and then the “Perm On” and the hand/dot symbols are displayed on the screen. In addition, a continuous band of segments is displayed on the left side and top of the screen and “Off” is switched to “On.”

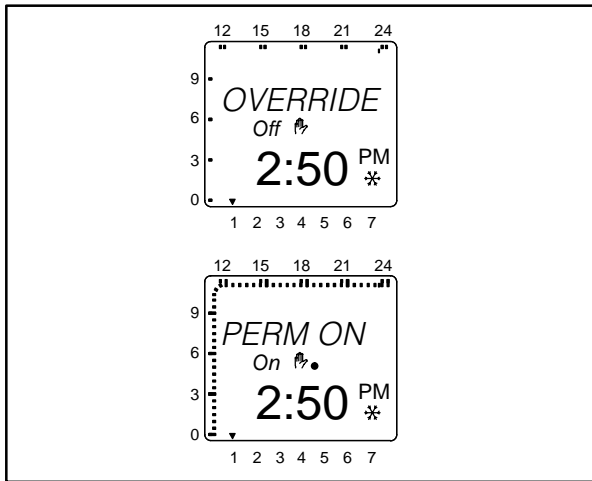

2. To switch to Permanent Off mode, press the + and – buttons for approximately two seconds. “Perm Off” is displayed and “On” is switched back to “Off.”

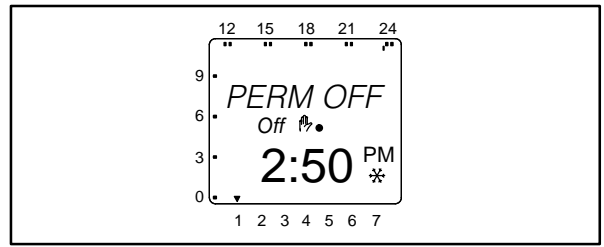

3. To return the clock to its original state, simultaneously press the + and – buttons for approximately one second. The original Home menu is redisplayed.

Selecting Permanent On/Off Mode With an Active Exercise

In the example shown below, “On” indicates that an exercise is currently active.

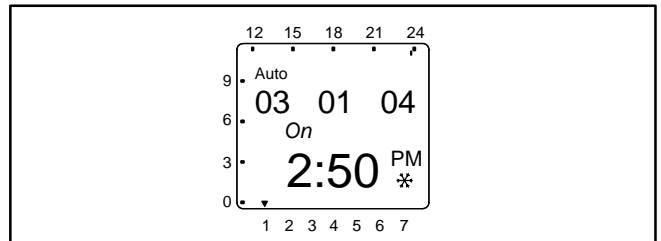

1. With the Home menu displayed, simultaneously press the + and – buttons for approximately two seconds. The Override menu is first displayed and then the “Perm Off” and the hand/dot symbols are displayed on the screen. In addition, “On” is switched to “Off.”

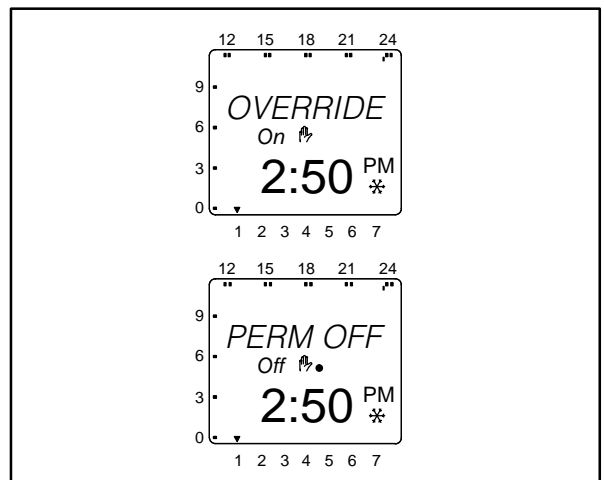

- To switch to Permanent On mode, press the **+** and **-** buttons for approximately two seconds. "Perm On" is displayed and "Off" is switched back to "On." In addition, a continuous band of segments is displayed on the left side and top of the screen.

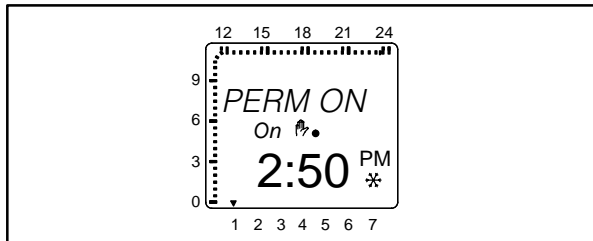

- To return the clock to its original state, simultaneously press the **+** and **-** buttons for approximately one second. The original Home menu is redisplayed.

Adding A Security Code

A 4-digit security code number can be entered to prevent unauthorized personnel from using the clock.

Once a security code has been set up, the exercise clock is locked 90 seconds after the last keystroke. It can only be operated again after the correct PIN code is entered.

CAUTION *Once a PIN code has been activated and the Reset button is pressed (see "Resetting the Timer" on the following page), the exercise timer can no longer be activated without a valid PIN code. The device must be replaced.*

- From the Home menu, press the **Menu** button. The Program menu is displayed.

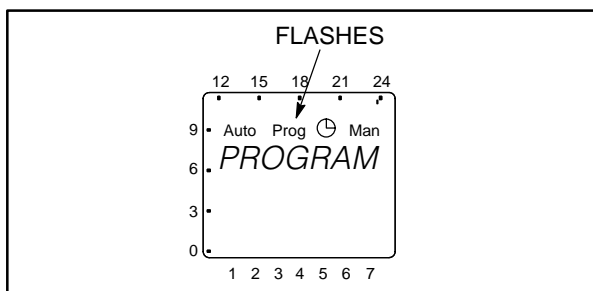

- Press the **+** button twice. The Date/Time menu is displayed, followed by the Manual menu.

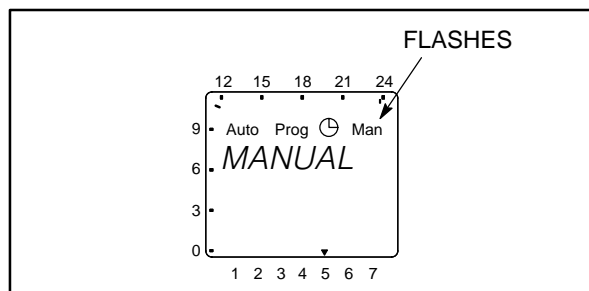

- Press the **ok** button to display the Pin menu.

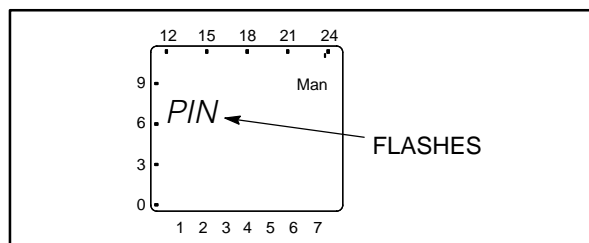

NOTE: If the **+** or **-** button is pressed now, the message "End" is displayed. Press the **ok** button to return to the Home menu.

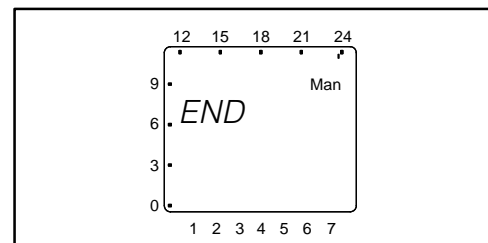

- Press the **ok** button to display the No PIN menu.

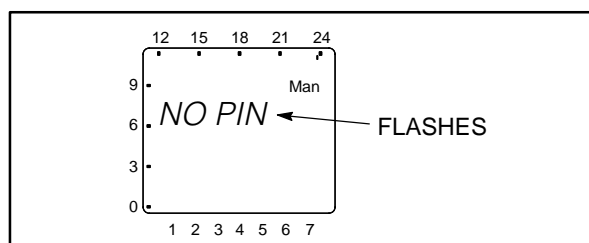

- Press the **+** or **-** buttons to display the With PIN menu.

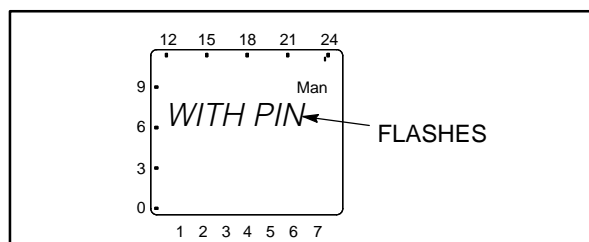

- Press the **ok** button to display the PIN Number menu.

NOTE: If you choose not to enter a 4-digit access code at this time, the only way to exit Manual mode is to press the reset (Res) button.

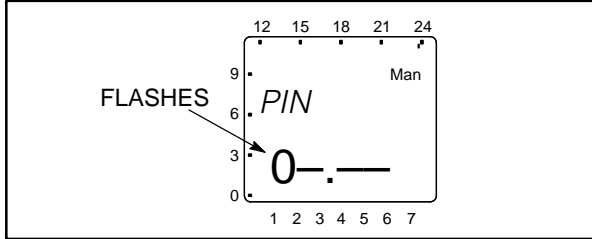

- Press the **+** or **-** buttons to enter the first digit of your 4-digit access code.
- Press the **ok** button. Then press the **+** or **-** buttons to enter the second digit of your 4-digit access code.
- Repeat step 8 for the third and fourth digit of your 4-digit access code.
- Press the **ok** button. The Home menu is then redisplayed.

After Programming the Exerciser Clock

- Make sure the External Exercise function on the transfer switch control panel is set to "On." For more information, see *Section 5*.
- Place the generator set operation selector switch in the Remote position.
- Check the system for proper operation as described in the Operator's Manual.

Resetting the Timer

The Reset button should only be used in cases of an emergency. Resetting the timer erases all existing language, date, and time settings. Upon pressing the **Res** button, the clock is set to 12:00 midnight, Wednesday, January 1, 2003. However, **scheduled exercise periods remain intact**.

- Use a pointed object to press the **Res** button for approximately one second. Two information

screens are displayed and the default national language is flashed.

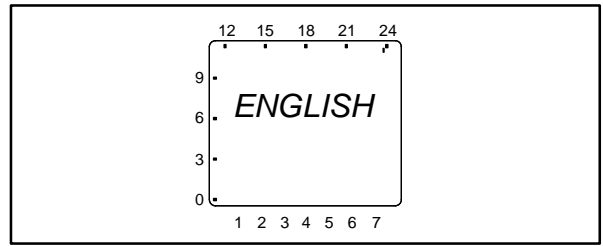

- If the incorrect language is being displayed, use the **+** or **-** button to scroll through the available languages (English, Espanol, Francais, Portugal, Italiano, or Deutsch).
- When the desired language is displayed, press the **ok** button. The year is displayed next.

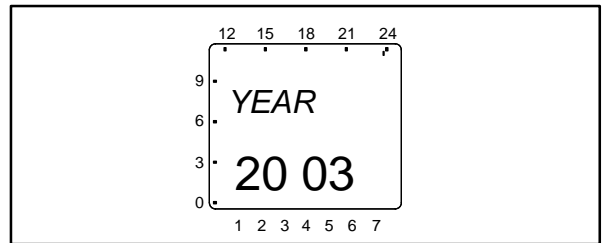

- Press the **+** button until the correct year is displayed and then press the **ok** button. The month is displayed next.

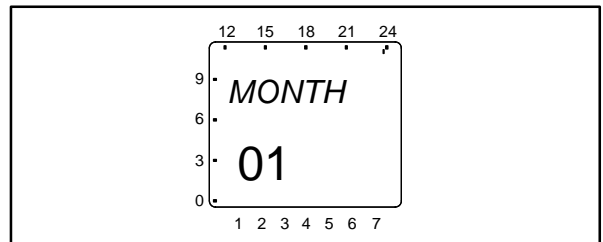

- Press the **+** or **-** button until the correct month is displayed and then press the **ok** button. The screen then shows the day value flashing.

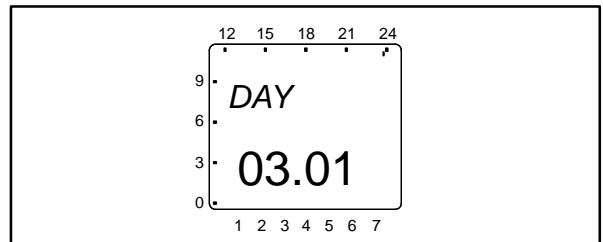

6. Press the **+** or **-** button until the correct day is displayed. Press the **ok** button. The screen then shows the hour value flashing.

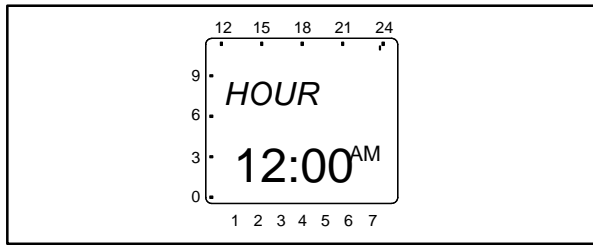

7. Press the **+** or **-** button until the correct hour is displayed. Press the **ok** button. The screen then shows the minute value flashing.

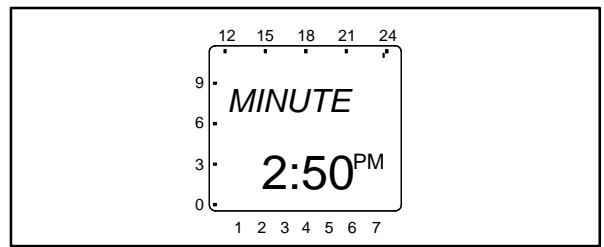

8. Press the **+** or **-** button until the correct minute is displayed. Press the **ok** button. The screen then displays the correct date and time.

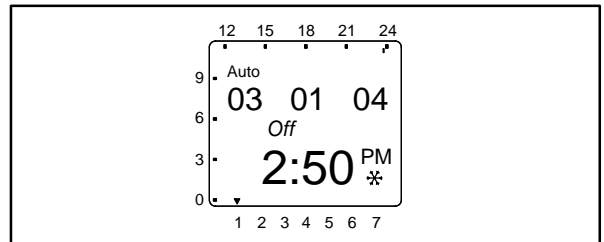

PLANNED MAINTENANCE

Performing the annual planned maintenance procedures increases reliability of the transfer switch.

The following procedures must be done only by trained and experienced personnel, according to procedures in the Section 8. If repair or component replacement is necessary, call your dealer or distributor.

⚠WARNING *AC power within the cabinet and the rear side of the cabinet door presents a shock hazard that can cause severe personal injury or death. Incorrect installation, service, or parts replacement can result in severe personal injury, death, and/or equipment damage. All corrective service procedures must be done only by technically qualified personnel, according to procedures in Section 9.*

⚠WARNING *The transfer switch presents a shock hazard that can cause severe personal injury or death unless all AC power is removed. Be sure to set the genset operation selector switch to Stop, disconnect AC line power, disconnect the battery charger from its AC power source, and disconnect the starting battery (negative [-] lead first) before servicing.*

⚠WARNING *Ignition of explosive battery gases can cause severe personal injury. Do not smoke or cause any spark, arc, or flame while servicing batteries.*

1. Disconnect All Sources of AC Power:

- A. Disconnect both AC power sources from the transfer switch before continuing. Turn the generator set operation selector switch to Stop. (The selector switch is located on the generator set control panel.)
- B. ***If there is an external battery charger, disconnect it from its AC power source.***
- C. Disconnect the set starting battery (negative [-] lead first).

2. Clean

- A. Thoroughly dust and vacuum all controls, meters, switching mechanism components, interior buswork, and connecting lugs.
- B. Close the cabinet door and wash **exterior** surfaces with a damp sponge (mild detergent and water). ***Do not allow water to enter the cabinet, especially at meters, lamps, and switches.***

3. Inspect

- A. Check buswork and supporting hardware for carbon tracking, cracks, corrosion, or any other types of deterioration. If replacement is necessary, call your dealer or distributor.
- B. Check stationary and movable contacts. If contact replacement is necessary, the procedures are described in the Section 8.
- C. Check system hardware for loose connections. Tighten as indicated in step 4.
- D. Check all control wiring and power cables (especially wiring between or near hinged door) for signs of wear or deterioration.
- E. Check all control wiring and power cables for loose connections. Tighten as indicated in step 4.
- F. Check the cabinet interior for loose hardware. Tighten as indicated in step 4.

4. Perform Routine Maintenance

- A. Tighten buswork, control wiring, power cables, and system hardware, as necessary. Hardware torque values are given in Section 7. Retorque all cable lug connections. Lug torque requirements are listed in section 1 of the Service manual.

5. Connect AC Power and Check Operation

- A. Connect the set starting battery (negative [-] lead last). Connect the utility AC power source, enable the genset power source. If applicable, connect power to the battery charger.
- B. Verify proper operation of the battery charger.
- C. Test system operation as described in this section. Close and lock the cabinet door.

5. Control Panel Configuration

The control panel can be used to configure ATS functions. When in **Configuration Mode**, the value code for the various control functions can be modified.

The control panel has a series of eight LEDs that display codes that indicate various control functions that can be configured. The first five LEDs display the function code and the last three LEDs display the value code for the displayed function (see Figure 5-1). A listing of the control functions (including the function and value codes) is included in Table 5-1. Additional information on these functions is included in *Section 4*.

NOTE: Two types of controls are available with GTEC transfer switches. Except for system nominal voltages, all control functions are the same for both types of controls. Units with line-to-neutral voltage sensing (TS1311 control) have fewer system nominal voltages available than units with line-to-line voltage sensing (TS1310 control). Nominal voltages

for both types of controls are listed in Table 5-1.

With the exception of the Test LED, the function and value LEDs are not lit during automatic operation (**Automatic Mode**).

ACCESSING THE FRONT PANEL CONFIGURATION EDITOR

⚠WARNING *AC power within the cabinet and the rear side of the cabinet door presents a shock hazard that can cause severe personal injury or death. Use extreme caution to avoid touching electrical contacts whenever the cabinet door is open.*

Battery power (DC power) must be available to configure the control panel functions. AC power may be present but doesn't have to be present to configure the control panel. To check for DC power, open the transfer switch door and place the ATS in the Normal or Emergency position. The Utility Power Connected or Genset Power Connected LED should light.

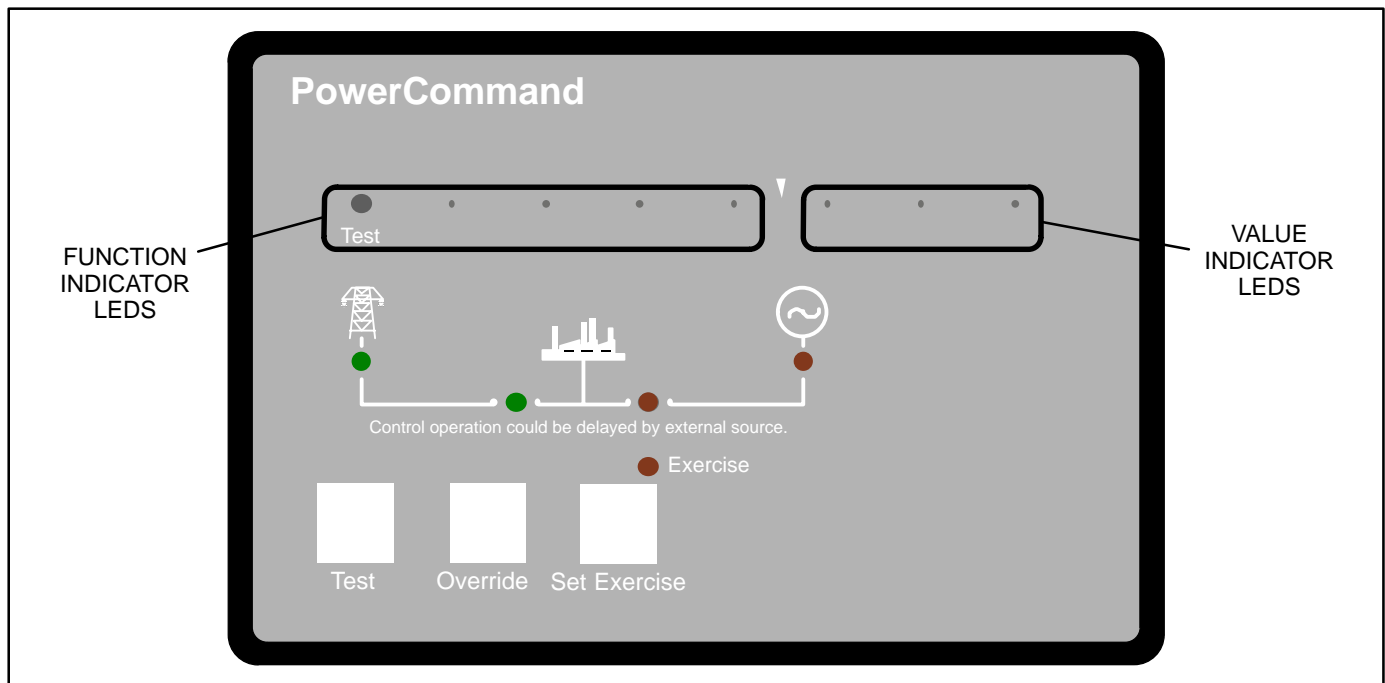



FIGURE 5-1. CONTROL PANEL

TABLE 5-1. ADJUSTABLE TRANSFER SWITCH FUNCTIONS

FUNCTION	FUNCTION CODE	VALUE CODE	VALUE (Default in bold italics)	Pg Ref
Not Available	○ ○ ○ ○ ○	NA NA NA		
TDES (Time Delay Engine Start)	○ ○ ○ ○ ●	○ ○ ○	0 Seconds (Disabled)	4-1
		○ ○ ●	0.5 Second	
		○ ● ○	1 Second	
		○ ● ●	2 Seconds	
		● ○ ○	3 Seconds	
		● ○ ●	4 Seconds	
		● ● ○	6 Seconds	
		● ● ●	10 Seconds	
TDNE (Time Delay Normal to Emergency)	○ ○ ○ ● ○	○ ○ ○	0 Seconds (Disabled)	4-1
		○ ○ ●	1 Second	
		○ ● ○	2 Seconds	
		○ ● ●	3 Seconds	
		● ○ ○	5 Seconds	
		● ○ ●	30 Seconds	
		● ● ○	120 Seconds	
		● ● ●	300 Seconds	
TDEN (Time Delay Emergency to Normal)	○ ○ ○ ● ●	○ ○ ○	0 Minutes (Disabled)	4-1
		○ ○ ●	0.1 Minutes (For Testing)	
		○ ● ○	5 Minutes	
		○ ● ●	10 Minutes	
		● ○ ○	15 Minutes	
		● ○ ●	20 Minutes	
		● ● ○	25 Minutes	
		● ● ●	30 Minutes	
TDEC (Time Delay Engine Cooldown)	○ ○ ● ○ ○	○ ○ ○	0 Minutes (Disabled)	4-1
		○ ○ ●	0.1 Minutes (For Testing)	
		○ ● ○	5 Minutes	
		○ ● ●	10 Minutes	
		● ○ ○	15 Minutes	
		● ○ ●	20 Minutes	
		● ● ○	25 Minutes	
		● ● ●	30 Minutes	
TDPT (Time Delay Program Transition)	○ ○ ● ○ ●	○ ○ ○	0 Seconds (Disabled)	4-2
		○ ○ ●	0.5 Second	
		○ ● ○	1 Second	
		○ ● ●	2 Seconds	
		● ○ ○	3 Seconds	
		● ○ ●	4 Seconds	
		● ● ○	6 Seconds	
		● ● ●	10 Seconds	
TDEL (Time Delay Elevator Signal)	○ ○ ● ● ○	○ ○ ○	0 Seconds (Disabled)	4-2
		○ ○ ●	1 Second	
		○ ● ○	2 Seconds	
		○ ● ●	3 Seconds	
		● ○ ○	5 Seconds	
		● ○ ●	30 Seconds	
		● ● ○	120 Seconds	
		● ● ●	300 Seconds	

TABLE 5-1. ADJUSTABLE TRANSFER SWITCH FUNCTIONS (CONT.)

FUNCTION	FUNCTION CODE	VALUE CODE	VALUE (Default in bold italics)		Pg Ref
Test With/Without Load	○ ○ ● ● ●	○ ○ ○	<i>Without Load</i>		4-5
		○ ○ ●	With Load		
External Exercise On/Off	○ ● ○ ○ ○	○ ○ ○	Off		4-8
		○ ○ ●	On		
Exercise With/Without Load	○ ● ○ ○ ●	○ ○ ○	<i>Without Load</i>		
		○ ○ ●	With Load		
System Nominal Voltage Table Selection	○ ● ○ ● ○	○ ○ ○	Table 1 ↓		
		○ ○ ●		Table 2 ↓	
System Nominal Voltage (TS1311 Control – Transfer Switches with Line-to-Neutral Voltage Sensing)	○ ● ○ ● ●	○ ○ ○	110	230	
		○ ○ ●	115	240	
		○ ● ○	120	255	
		○ ● ●	127	277	
		● ○ ○	139	347	
		● ○ ●	220	347	
System Nominal Voltage (TS1310 Control – Transfer Switches with Line-to-Line Voltage Sensing)	○ ● ○ ● ●	○ ○ ○	115	400	
		○ ○ ●	120	415	
		○ ● ○	190	440	
		○ ● ●	208	460	
		● ○ ○	220	480	
		● ○ ●	230	550	
		● ● ○	240	575	
		● ● ●	380	600	
System Nominal Frequency 50/60 Hz	○ ● ● ○ ○	○ ○ ○	60 Hz		
		○ ○ ●	50 Hz		
Single Phase/Three Phase	○ ● ● ○ ●	○ ○ ○	Three Phase		
		○ ○ ●	Single Phase		
Utility Undervoltage Pickup	○ ● ● ● ○	○ ○ ○	<i>90%</i>		4-7
		○ ○ ●	95%		
Utility Undervoltage Dropout	○ ● ● ● ●	○ ○ ○	90%		4-7
		○ ○ ●	<i>85%</i>		
		○ ● ○	80%		
		○ ● ●	70%		
Phase Check On/Off	● ○ ○ ○ ○	○ ○ ○	<i>Off</i>		4-7
		○ ○ ●	On		
Return to Programmed Transition On/Off	● ○ ○ ○ ●	○ ○ ○	<i>Off</i>		4-7
		○ ○ ●	On		
Elevator Post Transfer Delay On/Off	● ○ ○ ● ○	○ ○ ○	<i>Off</i>		4-2
		○ ○ ●	On		
Exercise Repeat Interval	● ○ ○ ● ●	○ ○ ○	<i>Every 7 Days</i>		4-8
		○ ○ ●	Every 14 Days		
		○ ● ○	Every 21 Days		
		○ ● ●	Every 28 Days		

 = THESE CONTROL FUNCTIONS ARE SET AT THE FACTORY AND SHOULD NOT REQUIRE ADJUSTING.

Configuration Mode is selected by operation of a small slide switch located on the back of the control panel. The switch is located near the bottom edge of the PCB (see Figure 5-2). The switch is partially hidden to prevent accidental operation.

NOTE: The **Configuration Mode** can be entered at any time, but once it is selected, all automatic operation is suspended.

MODIFYING THE CONFIGURATION

The control has been configured at the factory and does not require additional adjustments (default settings are shown in bold italics in Table 5-1). However, you may wish to adjust some of the settings for better performance.

CAUTION *Incorrect settings can result in the transfer switch failing to operate correctly. Only authorized trained personnel should make changes to the control function settings. External Exercise, System Nominal Voltage, System*

Nominal Frequency, and Single Phase/Three Phase settings are made at the factory and should not require any additional adjustments.

1. Slide the selector switch to the **Configuration Mode** position, as described on page 5-1. TDES is always the first function shown when entering Configuration Mode.
2. Press the **Test** pushbutton to scroll through the various control function codes displayed with the first five LEDs (see Table 5-1). The black-filled circles indicate which LEDs are lit for the function and value codes listed.
3. Once the desired function is selected, press the **Override** pushbutton to change the associated value code displayed with the last three LEDs.
4. When configuration is completed, return the selector switch back to the **Automatic Mode** position.

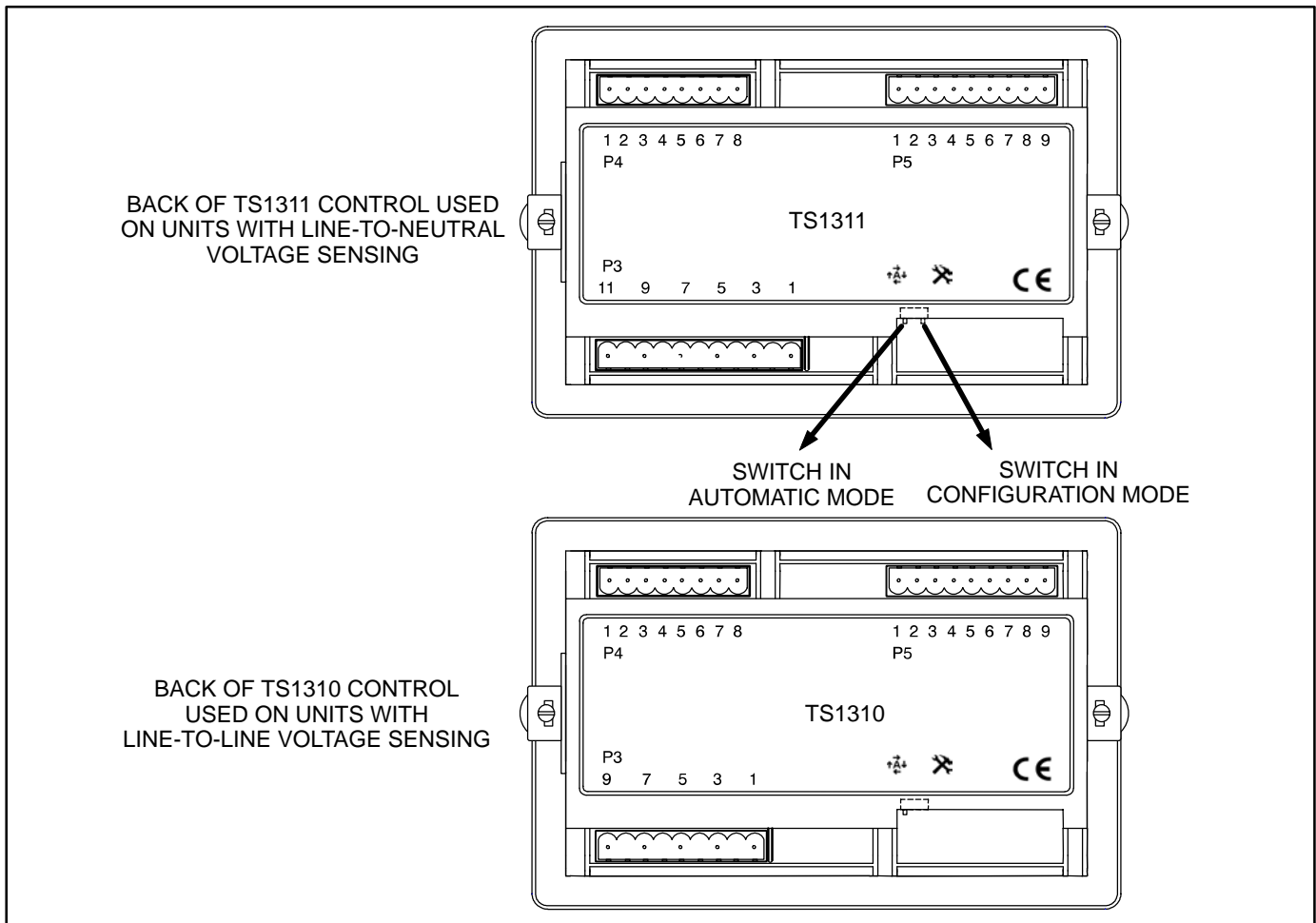

FIGURE 5-2. NORMAL/CONFIGURATION MODE SELECTOR SWITCH

6. Installation – Mounting

LOCATION

The location of the transfer switch in the existing electrical circuit varies with the application and the type of entrance switch. The location and wiring must comply with the contract drawings.

There must be a service disconnect in the commercial power line ahead of the transfer switch.

A typical installation is shown in Figure 6-1. Cabinet type IP32 dimensions and weights are listed in Table 6-1. Cabinet type IP54 dimensions and weights are listed in Table 6-2.

Choose a vibration-free mounting surface that supports the weight of the switch. Avoid locations that are near flammable liquids or gases, or are hot, moist, or dusty.

⚠WARNING *An electrical arc occurs during transfer that can ignite a flammable atmosphere, resulting in severe personal injury or death. The switch must not be located near batteries, fuel tanks, solvents, or other sources of flammable liquids or gases, or in areas sharing ventilation with such sources.*

TABLE 6-1. APPROXIMATE IP32 CABINET DIMENSIONS

Switch Current Rating	Height	Width	Depth With Door		Weight
			Closed	Open	
63, 100, & 125	31.5 in 800 mm	23.5 in 598 mm	11.6 in 296 mm	31.0 in 788 mm	105.8 lb 48 kg
160, 200, 225, 250, 350, 400, & 500	39.4 in 1000 mm	31.6 in 804 mm	11.6 in 296 mm	39.0 in 991.8 mm	143.3 lb 65 kg
630, 800, 1000. & 1250	53.9 in 1370 mm	29.5 in 750 mm	26.6 in 676 mm	51.9 in 1319 mm	406 lb 184 kg

TABLE 6-2. APPROXIMATE IP54 CABINET DIMENSIONS

Switch Current Rating	Height	Width	Depth With Door		Weight
			Closed	Open	
63, 100, & 125	34.0 in 864 mm	23.5 in 598 mm	11.6 in 296 mm	31.0 in 788 mm	110 lb 50 kg
160, 200, 225, 250, 350, 400, & 500	41.9 in 1064 mm	31.6 in 804 mm	11.6 in 296 mm	39.0 in 991.8 mm	143.3 lb 65 kg
630, 800, 1000. & 1250	53.9 in 1370 mm	29.5 in 750 mm	26.6 in 676 mm	51.9 in 1319 mm	414.5 lb 188 kg

MOUNTING METHODS

Transfer switches can be free-standing or mounted to a wall. Follow the appropriate set of mounting instructions and refer to the outline drawing for installation dimensions, specifications and mounting hole patterns.

Wall Mounting

Small and medium switches (63 thru 500 amps) are wall mounted (see Figure 6-1).

1. Check the location to be sure that no wires or plumbing, gas, or exhaust lines run behind the wall.
2. Install two mounting bolts in the wall for the cabinet mounting keyholes.

3. With the shipping box standing so the cabinet is upright, carefully remove the top and sides of the box.

4. Raise the cabinet and mount it on the two mounting bolts in the wall.

⚠WARNING *Improper lifting can cause severe personal injury. Have sufficient manpower for lifting and mounting the cabinet.*

5. Install the two remaining mounting bolts, but do not tighten them.

6. Push the cabinet against the wall. If the cabinet does not align flush against the wall, shim the mounting bosses as required.

7. Tighten all mounting bolts.

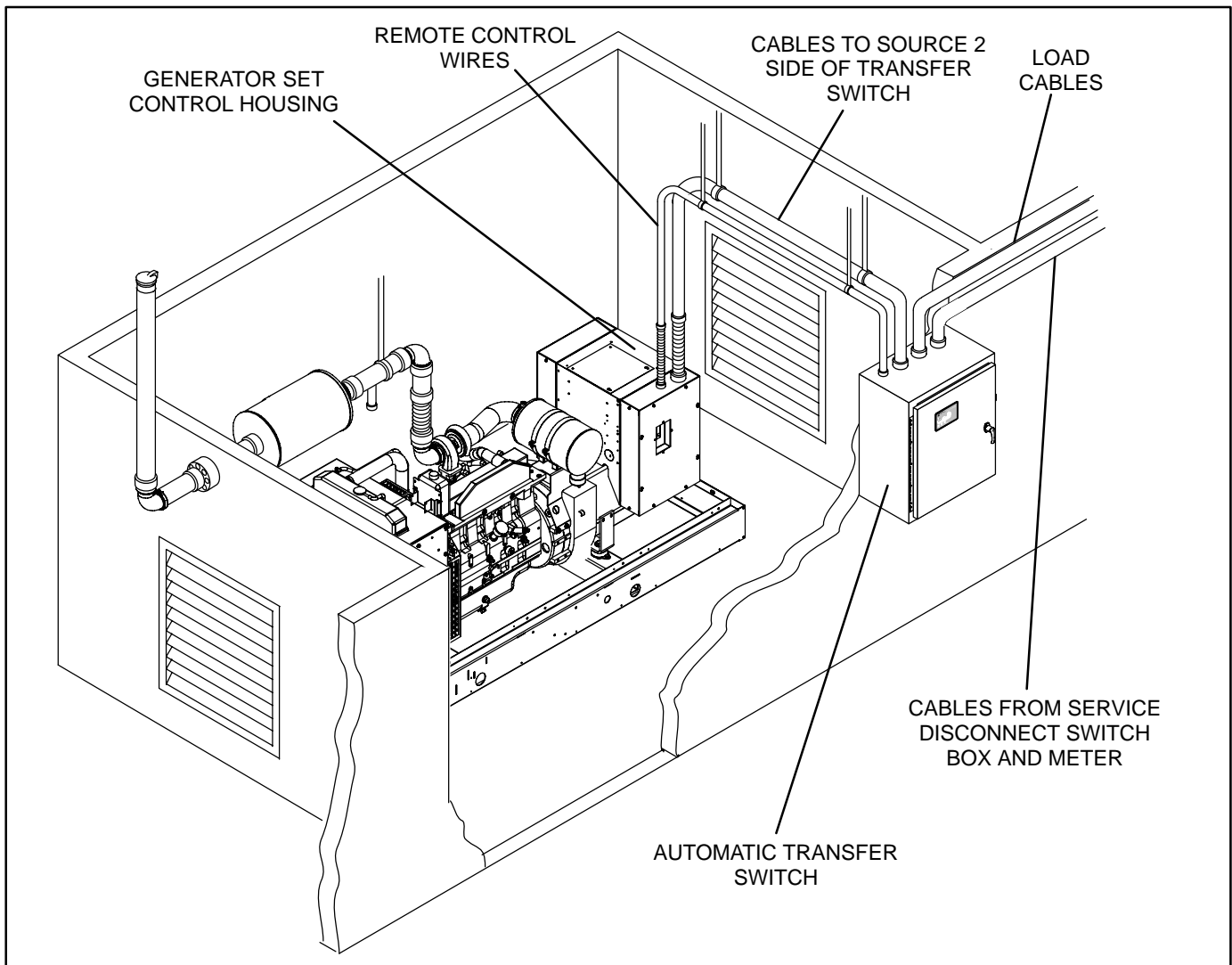

FIGURE 6-1. TYPICAL WALL-MOUNT INSTALLATION

Free-Standing

Large switches (630 thru 1250 amps) are floor mounted.

1. Adhere to all local codes.
2. Make sure adequate access to the rear of the cabinet is available for wire connections.
3. Provide stability by bolting the cabinet to the floor at all four corners.

OPEN CONSTRUCTION

Use a cabinet that meets the requirements of all local codes and standards. The door should be se-

cured and have safety warnings required to meet all applicable codes. The minimum cabinet size is determined by the current rating of the transfer switch. Refer to individual outline drawings for the minimum cabinet dimensions.

The outline drawings supplied with the transfer switch provide outline dimensions for mounting the transfer switch components inside the cabinet. Page one of the outline drawing shows hole patterns that must be drilled in the cabinet door to align various control components. Figure 6-2 shows page one of a typical outline drawing. Additional outline drawings are included in *Section 11*.

Refer to the Wiring section (*Section 7*) for electrical connections.

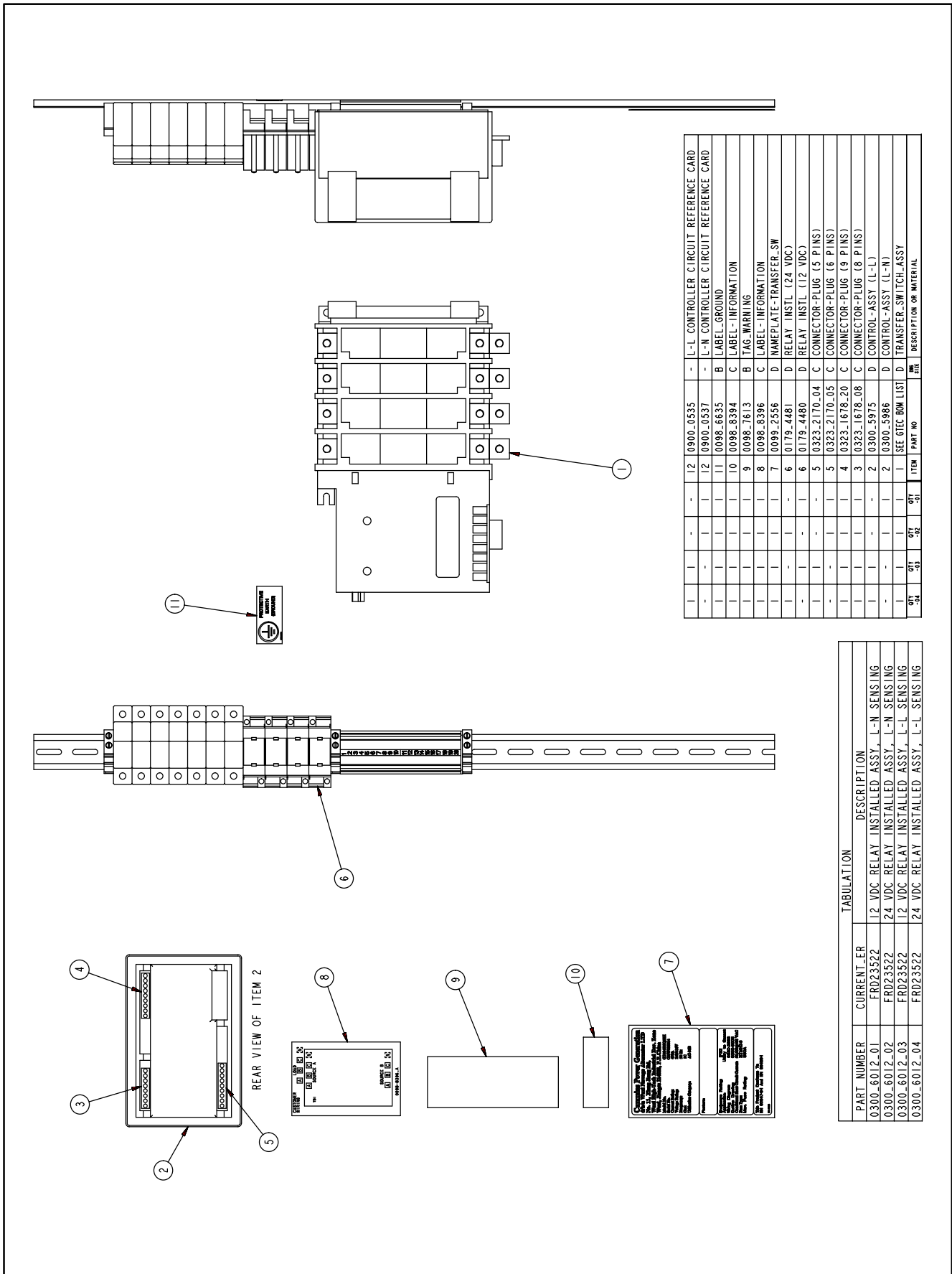

FIGURE 6-2. TYPICAL OPEN CONSTRUCTION FOR 250 AMP TRANSFER SWITCHES

7. Installation – Wiring

Refer to Figures 7-1 thru 7-3 for component locations.

⚠WARNING AC voltages and currents present an electrical shock hazard that can cause severe personal injury or death. Only trained and experienced personnel are to perform the following procedures.

When installing conduit, observe the following precautions:

1. Before beginning conduit installation, cover the transfer switch to prevent accidental entry of metal chips.
2. If using rigid conduit between the generator set and the transfer switch, install at least 2 feet

(610 mm) of flexible conduit between the rigid conduit and generator set to absorb vibration.

3. Run control circuit wiring in separate conduit from the AC wiring; otherwise, induced currents could cause operational problems within the switch. Cutouts can be made through the top, bottom, or sides of the cabinet. (Refer to the switch outline drawings included in Section 11.)

⚠CAUTION Installation debris can cause equipment failure and damage. Use extreme care to keep drill chips and filings out of the relays, contacts, and other parts of the automatic transfer switch when mounting or connecting conduit. Screwdrivers should be used carefully to prevent damage to components.

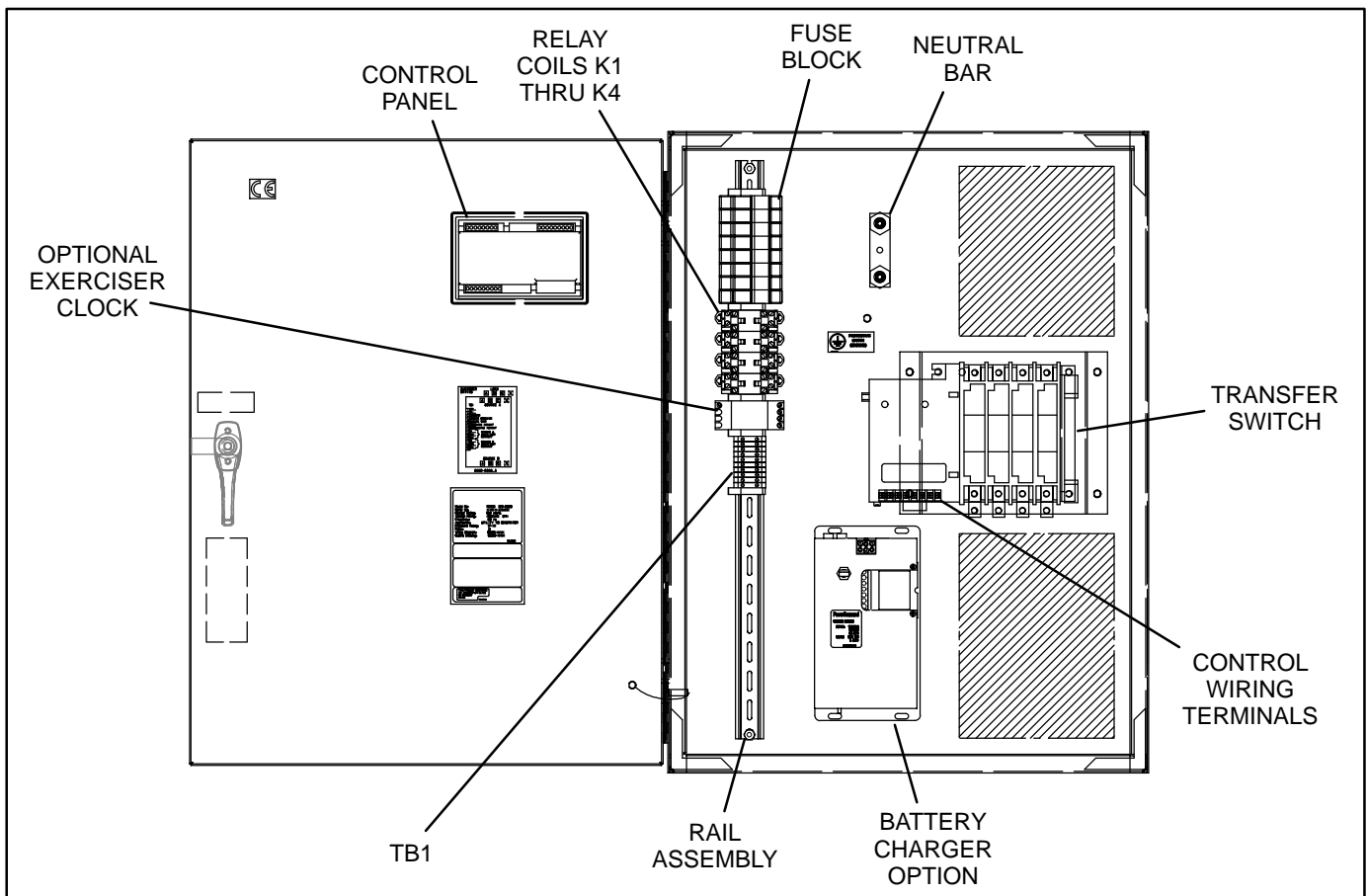

FIGURE 7-1. INTERIOR/COMPONENTS: 63-125 AMP, 4 POLE SWITCH

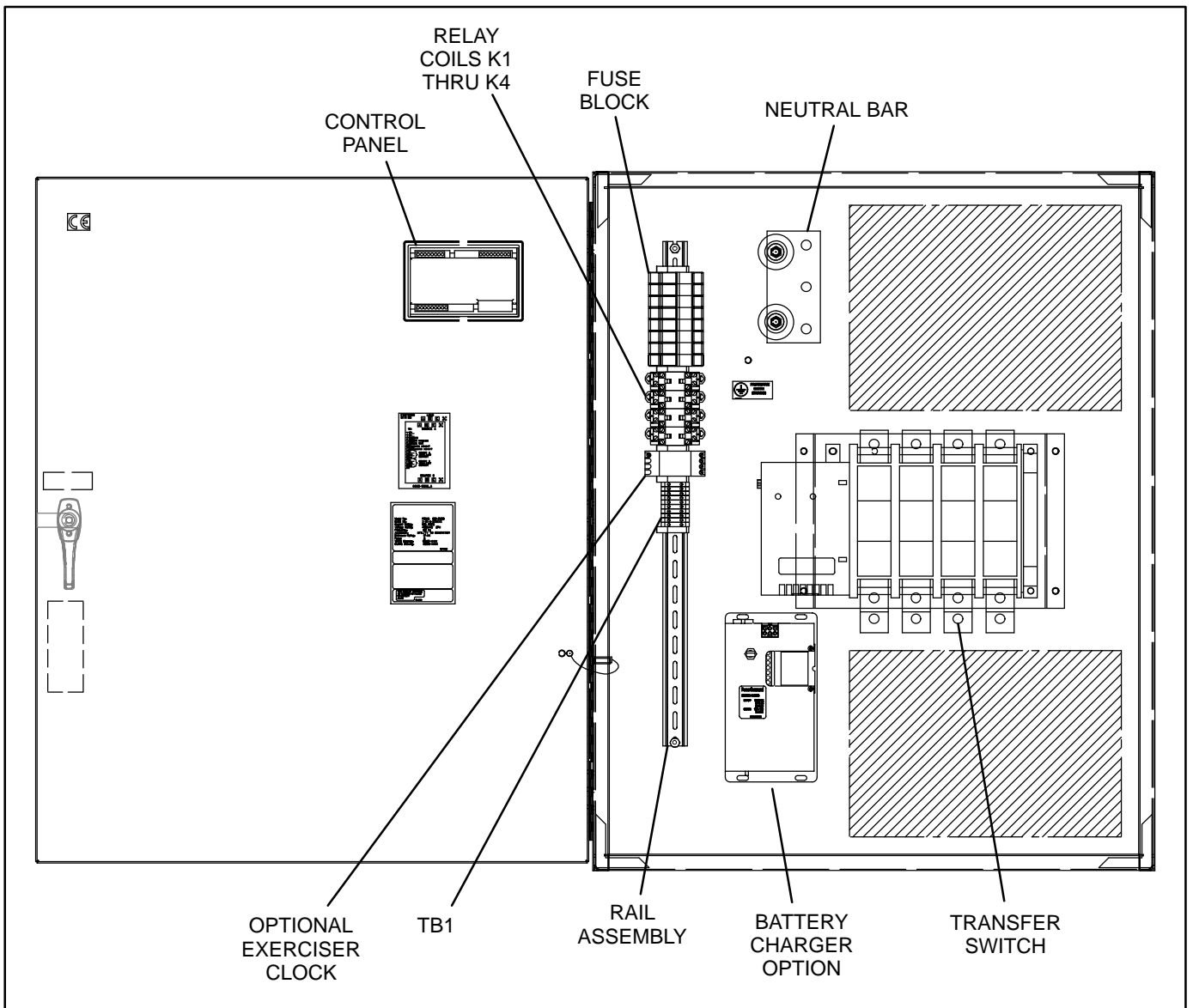

FIGURE 7-2. INTERIOR/COMPONENTS: 160-500 AMP, 4 POLE SWITCH

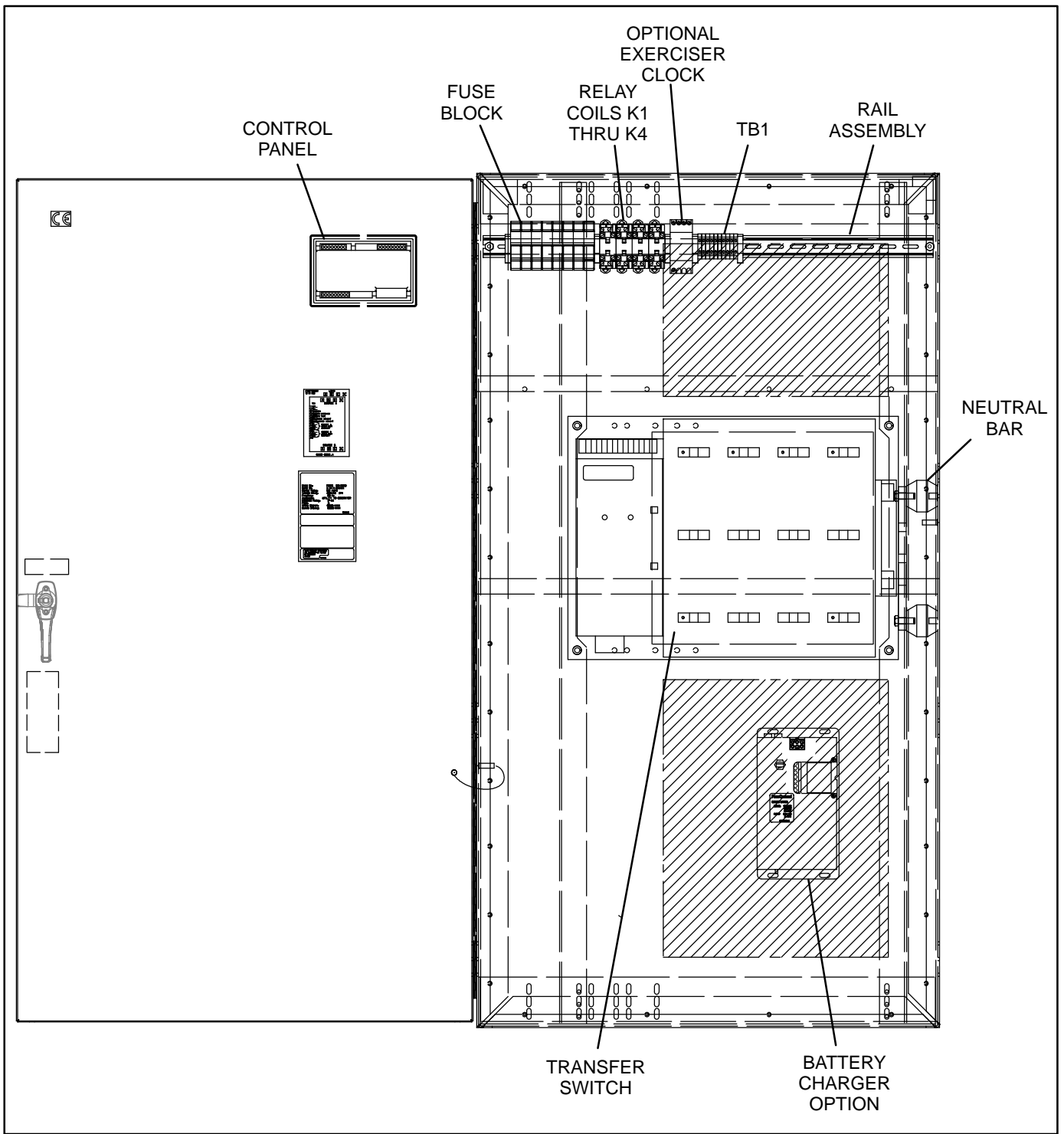

FIGURE 7-3. INTERIOR/COMPONENTS: 630-1250 AMP, 4 POLE SWITCH

AC CONNECTIONS

Perform wiring in the following sequence:

1. Test the operation of the generator set from its own controls.
2. Stop the generator set and remove the negative lead from the cranking battery to prevent starting.

⚠WARNING *Failure to prevent the generator set from starting before wiring procedures are performed presents a shock hazard that can cause severe personal injury or death. Disconnect generator set battery (negative (-) terminal first) before proceeding.*

3. Connect conductors of sufficient size (see contract drawings) to carry rated current from the line, load, and generator set directly to the transfer switch terminals, which are marked A, B, and C (A, B, C, and N on 4-pole switches). A neutral bar is standard on 3-pole switches. Phase rotation must be the same on the utility and genset power sources.

4. Connect power cables to the load terminals. Tighten the terminal lugs as indicated in Table 7-1.

TABLE 7-1. TERMINAL LUG TORQUES

Set Screw Socket Size (Across Flats)	Minimum Torque For Proper Operation
5 mm	9 N•m
6 mm	23 N•m
8 mm	30 N•m
10 mm	45 N•m
13 mm	60 N•m
14 mm	68 N•m

⚠WARNING *AC voltages and currents present an electrical shock hazard that can cause severe personal injury or death. Make sure that both AC power sources are disconnected.*

5. Make sure that both AC power sources are disconnected.

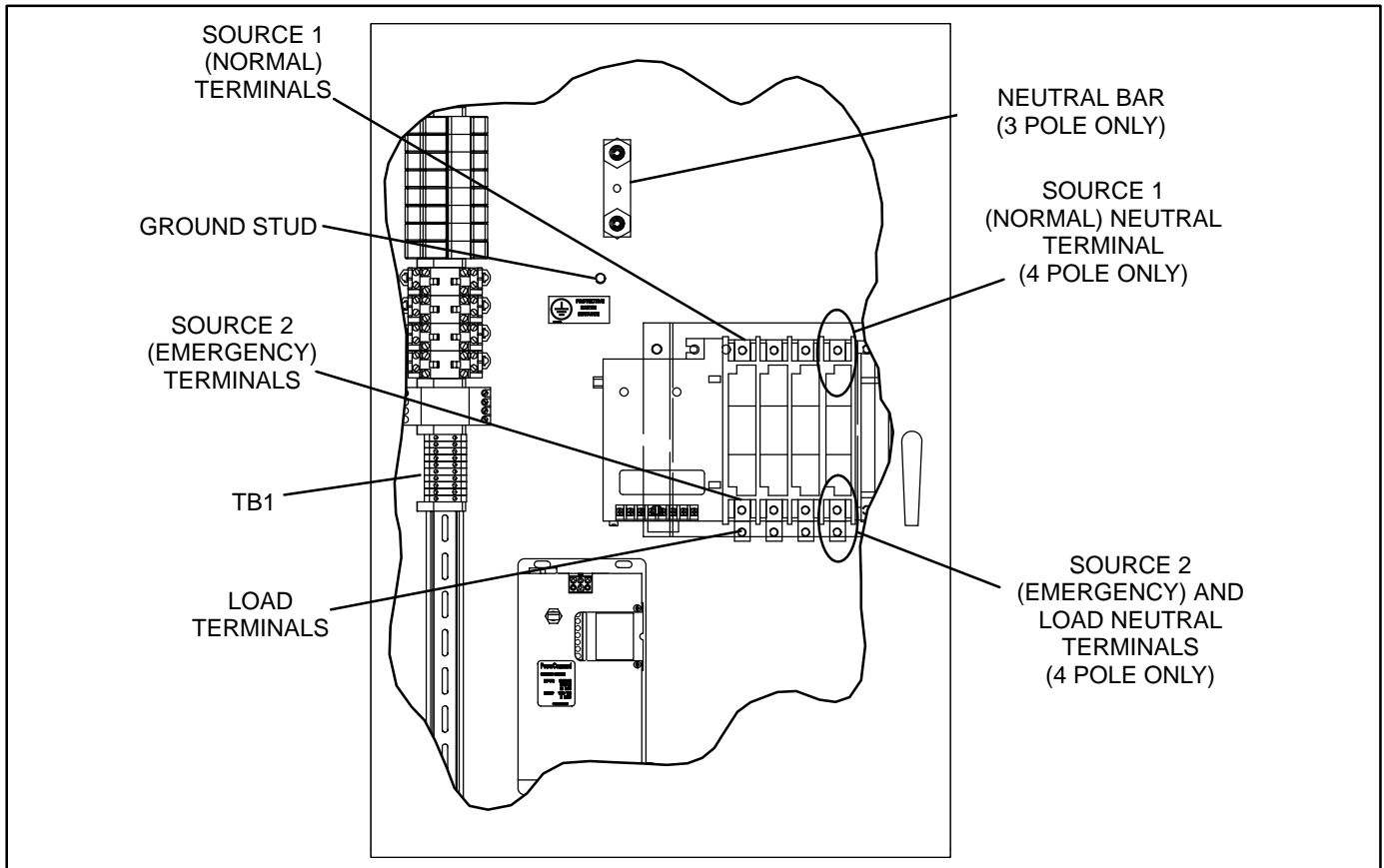

FIGURE 7-4. 63-500 AMPERE, 4 POLE TRANSFER SWITCH TERMINAL ACCESS (125 AMP SWITCH SHOWN) (2 AND 3 POLE SWITCHES ARE SIMILAR)

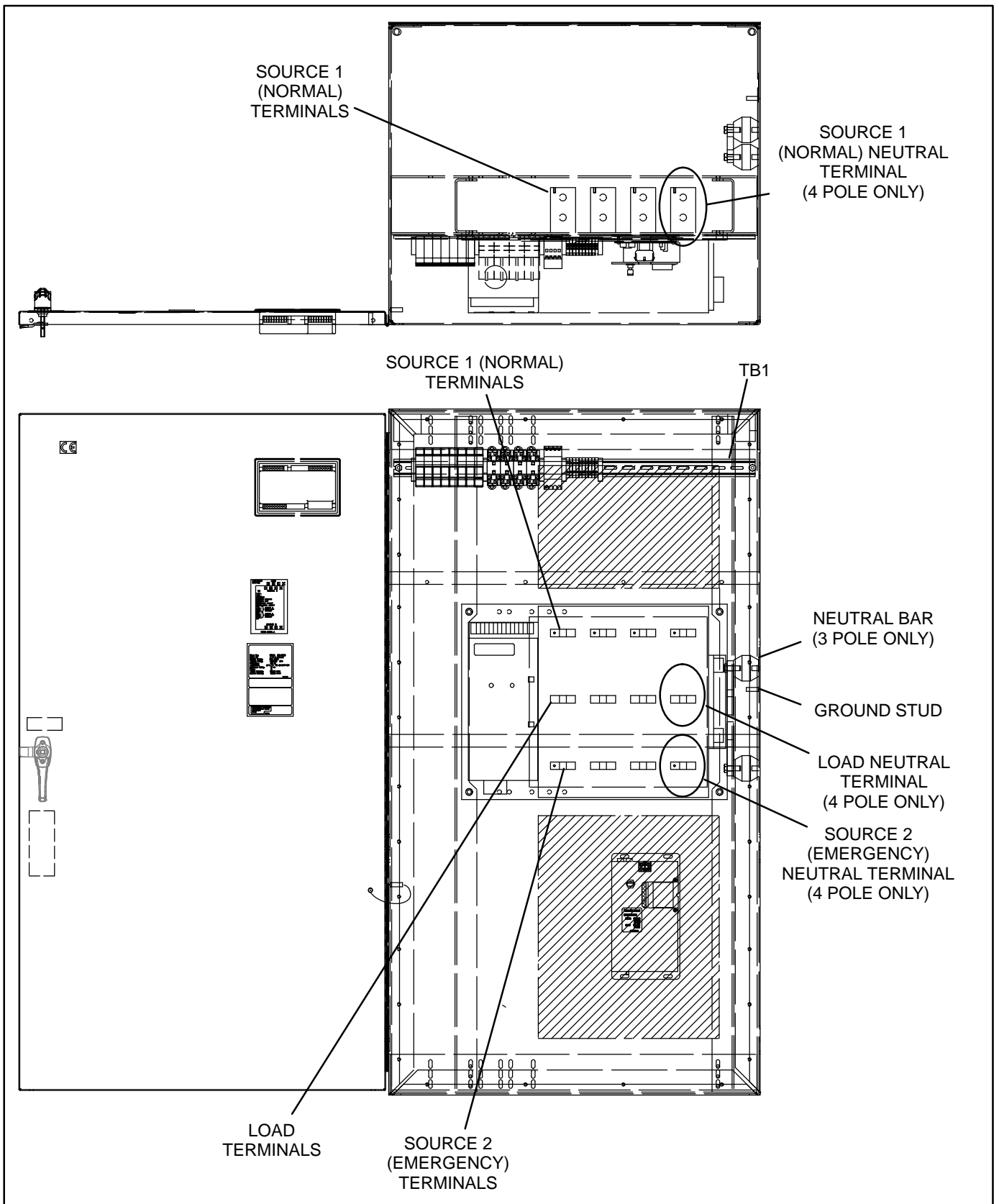

FIGURE 7-5. 600-1250 AMPERE, 4 POLE TRANSFER SWITCH TERMINAL ACCESS (1250 AMP SHOWN - OTHERS ARE SIMILAR)

CONTROL CONNECTIONS

Connections of standard and optional control wiring are made at terminal block TB1. TB1 is located near the bottom of the DIN rail see Figure 7-6).

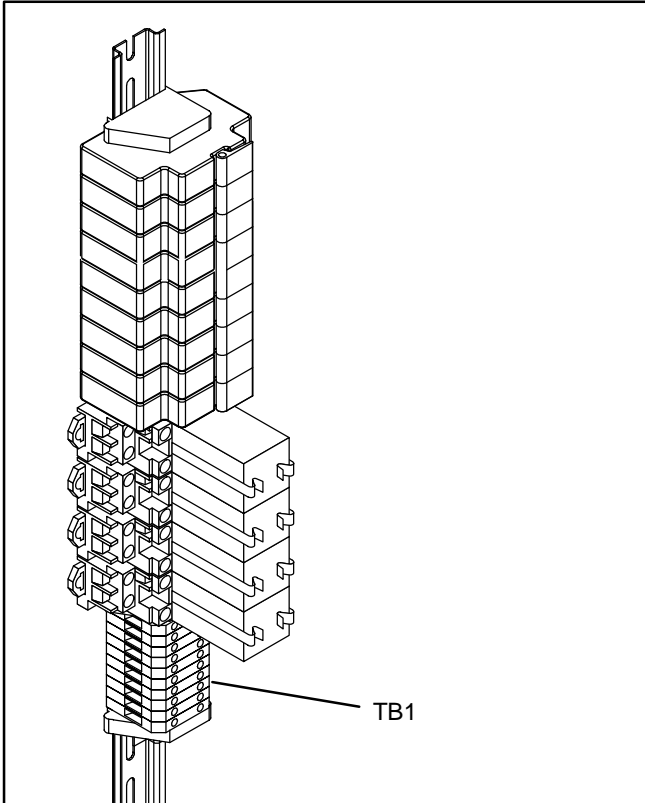

FIGURE 7-6. CONTROL WIRING CONNECTIONS

Connecting Transfer Switch to Genset

⚠WARNING AC voltages and currents present an electrical shock hazard that can cause severe personal injury or death. Disconnect the AC power source.

Wire size depends on the distance and the type of battery charger installed in the transfer switch. Refer to Table 7-2 to determine the wire size required.

- Use Column A for connections to TB1-2, 4, 5, 6, 7, 8, and, if equipped, the annunciator.

- Use Column B for connections to TB1-1 (GND) and TB1-3 (B+) if no battery charger is installed in the transfer switch.
- Use Column C for connections to TB1-1 (GND) and TB1-3 (B+) if a 2-Amp battery charger is installed in the transfer switch.
- Use Column D for connections to TB1-1 (GND) and TB1-3 (B+) if a 10-Amp battery charger is installed in the transfer switch.

TABLE 7-2. WIRE SPECIFICATIONS

Wire Size (AWG) [mm ²]	Distance in Meters, One Way (Multiply by 3.3 for Feet)			
	Column A	Column B	Column C	Column D
16 [1.5]	305	130	38	8
14 [2.5]	488	206	61	12
12 [4.0]	732	329	91	18
10 [6.0]	1219	523	152	31

Wire resistance must not exceed 0.5 ohm per line. Use stranded wire only. For connection to the screw terminal, strip the insulation back 3/8 inch (10 mm).

Remote starting (for Cummins Power Generation water-cooled generator sets only) uses terminals B+, GND (ground), and RMT of terminal block TB1 (Figure 7-8). Connect these terminals to like terminals on the generator set. Refer to Interconnect Wiring diagram shipped with the switch.

- For PCC 3100 and PCC 2100 genset controls, install a jumper between TB1-1 and TB1-2 for ground-to-start connection.
- For PCC 1301 genset controls, install a jumper between TB1-10 and TB1-11 for ground-to-start connection.
- For Detector 12 genset controls, install a jumper between TB1-2 and TB1-3 for B+ start.
- For PCC 3200 genset controls requiring a dry contact start, do not install a jumper.

Be sure to check the Interconnect Wiring diagram shipped with the transfer switch.

Auxiliary Contacts

Auxiliary contacts, for external alarm or control circuitry, are available for the Normal (utility power) and Emergency (genset power) sides of the transfer switch. Connections for the auxiliary contacts can be made on terminal block TB1 (Figure 7-7). The contacts have ratings of 5 amperes at 250 VAC. Figure 7-7 shows the normally open and normally closed positions of the auxiliary contacts with the transfer switch in the neutral position. Moving the transfer switch to Normal or Emergency actuates the corresponding auxiliary contacts.

Use number 22 (0.4 mm²) to number 12 AWG (4 mm²) wire. For connection to the screw terminal, strip the insulation back 3/8 inch (10 mm).

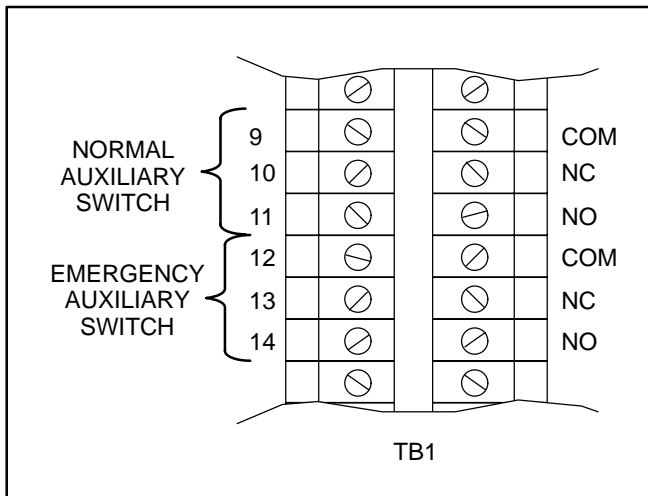

FIGURE 7-7. TERMINAL BLOCK TB1

Remote Start-Stop Connections

Use number 18 (1 mm²) to number 12 AWG (4 mm²) wire. Resistance must not exceed 0.5 ohm per line. Stranded wire is recommended. For connection to the screw terminal, strip the insulation back 3/8 inch (10 mm).

Remote starting (for Cummins Power Generation water-cooled generator sets only) uses terminals B+, GND (ground), and RMT of terminal block TB1 (Figure 7-8). Connect these terminals to like terminals on the generator set. Refer to your generator set wiring diagrams.

Connect a jumper between terminals 1 and 2 for PowerCommand control systems. Connect a jumper between terminals 2 and 3 for Detector Control systems. A jumper is not needed in any of the other systems.

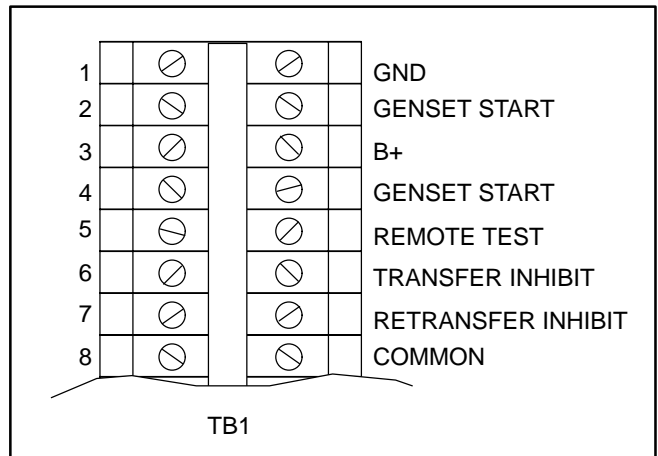

FIGURE 7-8. TB1 START CONNECTIONS, REMOTE TEST, AND TRANSFER/RETRANSFER INHIBIT

Remote Test Input

To add remote test, connect a normally open, dry contact between terminals 5 and 8 of TB1 (see Figure 7-9). Closing the contact activates the feature and opening the contact deactivates it.

Use number 22 (0.4 mm²) to number 12 AWG (4 mm²) wire. For connection to the screw terminal, strip the insulation back 3/8 inch (10 mm).

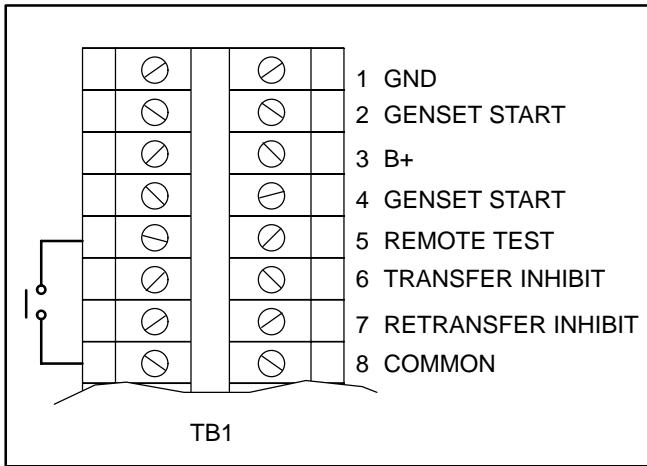

FIGURE 7-9. TB1 CONNECTIONS FOR REMOTE TEST TRANSFER

Transfer Inhibit Input

To add transfer inhibit, connect a normally open, dry contact between terminals 6 and 8 of TB1 (see Figure 7-10). Closing the contact enables the feature and opening the contact disables it.

Use number 22 (0.4 mm²) to number 12 AWG (4 mm²) wire. For connection to the screw terminal, strip the insulation back 3/8 inch (10 mm).

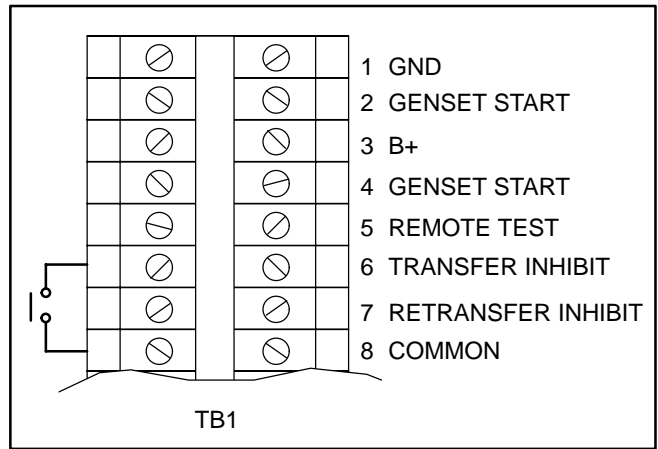

FIGURE 7-10. TB1 CONNECTIONS FOR TRANSFER INHIBIT

Retransfer Inhibit Inhibit

To add retransfer inhibit, connect a normally open, dry contact between terminals 7 and 8 of TB1 (see Figure 7-11). Closing the contact enables the feature and opening the contact disables it.

Use number 22 (0.4 mm²) to number 12 AWG (4 mm²) wire. For connection to the screw terminal, strip the insulation back 3/8 inch (10 mm).

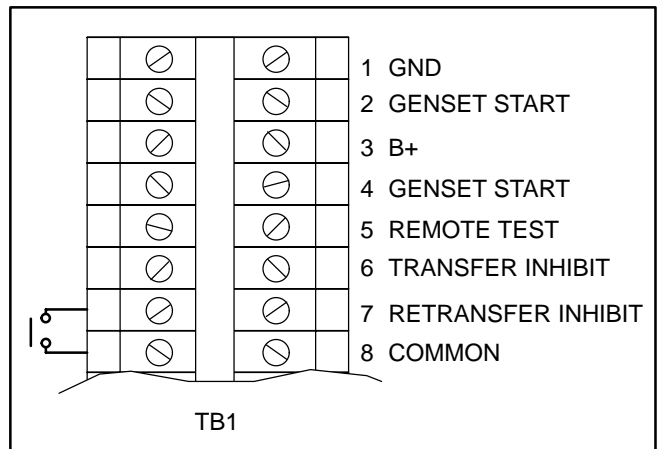

FIGURE 7-11. TB1 CONNECTIONS FOR RETRANSFER INHIBIT

Remote Override Input

The transfer switch may be wired with a remote Override Switch that functions the same as the control panel Override pushbutton.

To add remote override, connect a normally open, dry (voltage free) contact between P4-2 on the back

of the control panel and TB1-8 (see Figure 7-12). Closing the contact enables the feature and opening the contact disables it.

Use number 22 (0.4 mm²) to number 12 AWG (4 mm²) wire. For connection to the screw terminal, strip the insulation back 3/8 inch (10 mm).

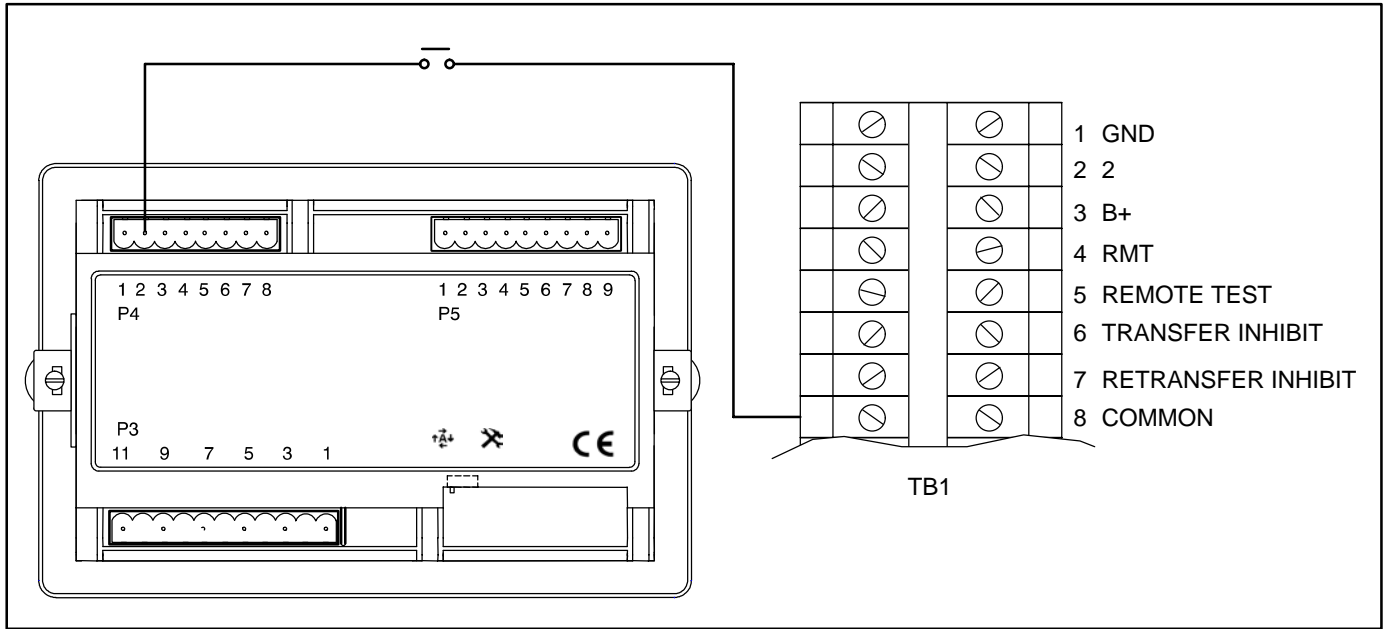

FIGURE 7-12. CONNECTIONS FOR REMOTE OVERRIDE INPUT

INSPECTION AND CLEANUP

- Inspect all wiring to be certain that:
 - Wiring does not interfere with switch operation
 - Wiring is not damaged as the door opens and closes
 - Wiring does not contact sharp or abrasive surfaces
 - No wiring is left loose and unconnected
- After mounting and wiring the cabinet, clean the interior with a vacuum cleaner to remove any chips, filings, or dirt from the cabinet interior and components.
- Double check the power supply voltages to make sure they match the voltages listed on the nameplate. Some installations with a non-standard nameplate require that the voltage rating and frequency be recorded.
 - An example of a standard nameplate is shown in Figure 1-3.
 - Examples of non-standard nameplates are shown in Figures 7-13, 7-14, and 7-15. This nameplate is used when the Model Identification Number includes voltage codes X, Y, or Z.
 1. Remove the Factory Default Setting label located on the control (see Figure 7-17) and the tag attached inside the transfer switch (see Figure 7-18). Examples of these labels/tags are shown in see Figure 7-19.
 2. If the power supply voltage and frequency for your installation matches the default setting listed on the label, record the settings on the Site Set-up label located next to the nameplate on the inside of the transfer switch door (see Figure 7-16).

⚠ CAUTION *Incorrect settings can result in the transfer switch failing to operate correctly. To avoid equipment malfunction and damage, make sure the control*

is configured to match the power supply voltage and frequency.

3. If the power supply voltage and frequency for your installation does not match the default setting listed on the label, access the configuration editor on the transfer switch control and change the voltage/frequency settings to match your installation. Refer to the Section 5 of this manual for information on how to adjust these settings. Record the settings on the Site Set-up label located next to the nameplate on the inside of the transfer switch door (see Figure 7-16).

Cummins Power Generation	
Model No.	GT40063XN52A000
Serial No.	E05W000083
Current Rating:	63A
Voltage Rating:	110/190V; 115/200V; 120/208V; 127/220V; 139/240V
Frequency:	50/60 Hz
Class:	PC
Utilization Category:	AC-31B
Feature: S901;R971;A027;A045;A035;B901;A042; L989;M033;J030-7;M032-7;K001-7;L201-7	
Enclosure Rating:	IP32
Application:	Utility to Genset
Wiring Diagram:	0630-2993
Outline Drawing:	0300-6004
Conditional Short Circuit Current:	26,000A @480 VAC
Fuse type:	RT16NT-00
Max. Fuse Rating:	63A
THIS PRODUCT CONFORMS TO EN 60947-6-1 AND EN 60439-1	

FIGURE 7-13. NAMEPLATE FOR TRANSFER SWITCH WITH “X” VOLTAGE CODE

Cummins Power Generation	
Model No.	GT40063YN52A000
Serial No.	E05W000083
Current Rating:	63A
Voltage Rating:	220/380V; 230/400V; 240/416V
Frequency:	50/60 Hz
Class:	PC
Utilization Category:	AC-31B
Feature: S901;R976;A027;A045;A035;B901;A042; L989;M033;J030-7;M032-7;K001-7;L201-7	
Enclosure Rating:	IP32
Application:	Utility to Genset
Wiring Diagram:	0630-2993
Outline Drawing:	0300-6004
Conditional Short Circuit Current:	26,000A @480 VAC
Fuse type:	RT16NT-00
Max. Fuse Rating:	63A
THIS PRODUCT CONFORMS TO EN 60947-6-1 AND EN 60439-1	

FIGURE 7-14. NAMEPLATE FOR TRANSFER SWITCH WITH "Y" VOLTAGE CODE

Cummins Power Generation	
Model No.	GT40063ZN52A000
Serial No.	E05W000083
Current Rating:	63A
Voltage Rating:	225/440V; 277/480V
Frequency:	50/60 Hz
Class:	PC
Utilization Category:	AC-31B
Feature: S901;R979;A027;A045;A035;B901;A042; L989;M033;J030-7;M032-7;K001-7;L201-7	
Enclosure Rating:	IP32
Application:	Utility to Genset
Wiring Diagram:	0630-2993
Outline Drawing:	0300-6004
Conditional Short Circuit Current:	26,000A @480 VAC
Fuse type:	RT16NT-00
Max. Fuse Rating:	63A
THIS PRODUCT CONFORMS TO EN 60947-6-1 AND EN 60439-1	

FIGURE 7-15. NAMEPLATE FOR TRANSFER SWITCH WITH "Z" VOLTAGE CODE

Actual Site Set-up Values	
Voltage Rating:	_____
Frequency:	_____
Control Voltage:	_____
Date Commissioned:	_____

FIGURE 7-16. SITE SET-UP LABEL



FIGURE 7-17. FACTORY DEFAULT SETTING LABEL ON CONTROL

- Double check the phase rotation. The Normal side phase rotation must match the Emergency side phase rotation.
- Verify that the remote start connections are correct for your application. For more information on jumper replacement, determine the control type and refer to information provided earlier in this section.
- Manually operate the automatic transfer switch (ATS) with power off to make sure it operates smoothly, with no binding. If it does

not operate smoothly, check for damage that may have occurred during shipping or installation. Also check for installation debris.



FIGURE 7-18. FACTORY DEFAULT SETTING TAG

<p style="text-align: center;">○</p> <p style="text-align: center;">Factory Default Setting: Voltage Rating: 110/190V Frequency: 50 Hz</p> <p>CAUTION: If the supply voltage and frequency are not the same as the above default, the controller configuration MUST BE changed to avoid severe damage to the controller. Refer to the Operator's Manual for information on making this adjustment. When completed, the Voltage/Frequency settings must be recorded on the unit nameplate.</p>	<p style="text-align: center;">○</p> <p style="text-align: center;">Factory Default Setting: Voltage Rating: 220/380V Frequency: 50 Hz</p> <p>CAUTION: If the supply voltage and frequency are not the same as the above default, the controller configuration MUST BE changed to avoid severe damage to the controller. Refer to the Operator's Manual for information on making this adjustment. When completed, the Voltage/Frequency settings must be recorded on the unit nameplate.</p>	<p style="text-align: center;">○</p> <p style="text-align: center;">Factory Default Setting: Voltage Rating: 255/440V Frequency: 50 Hz</p> <p>CAUTION: If the supply voltage and frequency are not the same as the above default, the controller configuration MUST BE changed to avoid severe damage to the controller. Refer to the Operator's Manual for information on making this adjustment. When completed, the Voltage/Frequency settings must be recorded on the unit nameplate.</p>
<p>110 VAC Mechanism Solenoid Coil</p>	<p>220 VAC Mechanism Solenoid Coil</p>	<p>277 VAC Mechanism Solenoid Coil</p>

FIGURE 7-19. FACTORY DEFAULT SETTING TAGS

8. Troubleshooting

The first part of this section includes a description of the control LED indicators and provides preliminary troubleshooting checks for operators and service personnel.

The second part of this section describes a typical transfer switch sequence of events, and provides detailed troubleshooting procedures for experienced service personnel. The troubleshooting pro-

cedures use conditional schematics and symptoms to diagnose all possible problems.

CONTROL PANEL LED INDICATORS

The control panel contains six LED indicators that provide some information about the current control status and may be helpful in troubleshooting the transfer switch (see Figure 8-1). Descriptions of these indicators are included in Table 8-1.

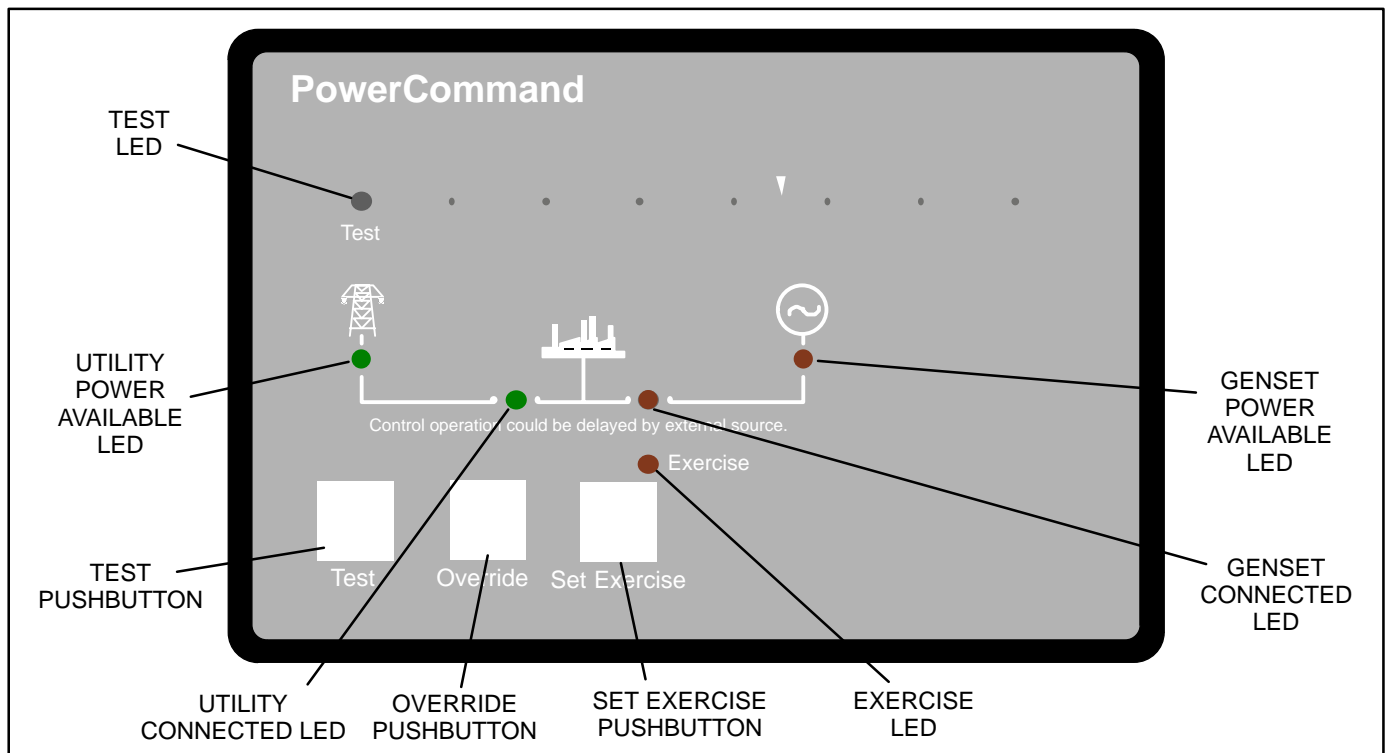

FIGURE 8-1. CONTROL PANEL

TABLE 8-1. CONTROL PANEL LED INDICATORS

Indicator	Definition
Utility (Normal) Power Available	This indicator lights when the utility source voltage sensor has determined that Utility power is available and is within acceptable voltage limits.
Utility (Normal) Connected	<ol style="list-style-type: none">1. Lights constantly when the transfer switch is connected to the Utility.2. Blinks once per second when the transfer switch has failed to connect to or disconnect from the Utility when commanded.3. Is off when the transfer switch is not connected to the Utility.
Genset (Emergency) Power Available	This indicator lights when the generator source voltage sensor has determined that generator power is within acceptable voltage and frequency limits.
Genset (Emergency) Connected	<ol style="list-style-type: none">1. Lights constantly when the transfer switch is connected to the Genset.2. Blinks once per second when the transfer switch has failed to connect to or disconnect from the Genset when commanded.3. Is off when the transfer switch is not connected to the Genset.
Exercise	<p>The following describes the Exercise LED when an exercise is enabled.</p> <ol style="list-style-type: none">1. Lights constantly when integrated repeat exercise periods have been set.2. Blinks twice per second when the Set Exercise button is pressed and held to set or cancel an integrated exercise period.3. Blinks once per second when an integrated or external exercise period is active.4. Is off when no integrated repeat exercise periods are set.
Test	<ol style="list-style-type: none">1. This indicator blinks at two times per second rate during the two seconds that the Test button is pressed to acknowledge that a test has been activated or when the remote test input is grounded.2. The indicator lights constantly during the test and goes out once the test is terminated or normal power has failed.3. The indicator blinks at two times per second rate during the two seconds to acknowledge that the Test button has been pressed to cancel a Test. The light then goes out.

TROUBLESHOOTING PROCEDURES FOR OPERATORS AND SERVICE PERSONNEL

The following procedures describe preliminary troubleshooting checks. These checks can be used by both the operator and service personnel. If the trouble persists, call your dealer or distributor.

⚠WARNING *Some ATS service procedures present hazards that can result in severe personal injury or death. Only trained and experienced service personnel with knowledge of electricity and machinery hazards should perform service.*

Diagnosis of problems involves observing system operation. If you cannot determine the problem, contact Cummins/Onan Service.

⚠WARNING *AC power within the cabinet and the rear side of the cabinet door presents a shock hazard that can cause severe personal injury or death. Whenever the cabinet door is open, use extreme caution to avoid touching electrical contacts with body, tools, jewelry, clothes, hair, etc.*

Several of the steps listed on the following pages include checking on the control panel settings. To check the control settings, open the transfer switch door and slide the selector switch on the back on the control panel to the Configuration Mode position. Additional information on configuring the control panel is included in *Section 5*.

Power Outage Occurs, But Generator Set Does Not Start

⚠WARNING *AC power within the cabinet and the rear side of the cabinet door presents a shock hazard that can cause severe personal injury or death. Whenever the cabinet door is open, use extreme caution to avoid touching electrical contacts with body, tools, jewelry, clothes, hair, etc.*

1. Verify that the operation selector switch on the generator set control panel is set to the Remote position. Check for fault indicators on the generator set control.
2. Start the generator set using its start-stop controls. If it does not crank, check the starting batteries. If it cranks but does not start, check the fuel supply. If the problem persists, call your dealer or distributor.

⚠WARNING *Ignition of explosive battery gases can cause severe personal injury. Do not smoke or cause any spark or flame while servicing batteries.*

⚠WARNING *Ignition of fuel can cause severe personal injury or death by fire or explosion. Do not permit any flame, cigarette, spark, pilot light, arcing equipment, or other possible source of ignition near the fuel system.*

Generator Set Starts During Normal Power Service

⚠WARNING *AC power within the cabinet and the rear side of the cabinet door presents a shock hazard that can cause severe personal injury or death. Whenever the cabinet door is open, use extreme caution to avoid touching electrical contacts with body, tools, jewelry, clothes, hair, etc.*

1. Verify that the operation selector switch on the generator set control panel is set to the Remote position.
2. Check the Utility Power Available LED on the control panel to see if it is lit.

If the Utility Power Available LED is lit,

- a. Check the Active Exercise LED to see if it is in an exercise period.

NOTE: If the exercise period occurs at an unexpected time or for an excessive duration, refer to the exerciser clock programming procedure or call your dealer or distributor.

- b. Momentary voltage dips might cause voltage sensors to initiate generator set starting. Check the utility undervoltage parameter settings on the control panel. Increase the TDES setting.

If the Utility Power Available LED is not lit,

- a. Check the control setting to verify that the system nominal voltage matches what is listed on the nameplate.
 - b. Check the control setting to verify that the system frequency matches what is listed on the nameplate.
 - c. Check the control setting to verify that the system phase setting matches what is listed on the nameplate.
 - d. Check the control setting to verify that the utility undervoltage dropout point is set lower than the pickup set point.
3. If the problem persists, call your dealer or distributor.

Generator Set Does Not Exercise

⚠WARNING *AC power within the cabinet and the rear side of the cabinet door presents a shock hazard that can cause severe personal injury or death. Whenever the cabinet door is open, use extreme caution to avoid touching electrical contacts with body, tools, jewelry, clothes, hair, etc.*

1. Verify that the operation selector switch on the generator set control panel is set to the Remote position.
2. If the optional external exerciser is installed, verify that the External Exercise function has been set to On.
3. Check the Exercise LED on the control panel to see if it is lit.
 - a. If the Exercise LED is not lit, no exercise period has been set. Refer to the exerciser programming procedure for information on setting an exercise.
 - b. If the Exercise LED is lit but not flashing, the exercise period has not yet started. Integrated exercisers do not display exercise start and stop times. If the optional external exerciser is enabled, check the exercise clock to see when an exercise is scheduled.
4. Start the generator set using its start-stop controls. If it does not crank, check the starting batteries. If it cranks but does not start, check the fuel supply.

⚠WARNING *Ignition of explosive battery gases can cause severe personal injury. Do not smoke or cause any spark or flame while servicing batteries.*

⚠WARNING *Ignition of fuel can cause severe personal injury or death by fire or explosion. Do not permit any flame, cigarette, spark, pilot light, arcing switch or equipment, or other possible source of ignition near the fuel system.*

5. If the problem persists, call your dealer or distributor.

After a Power Failure, the Generator Set Starts But Does Not Assume the Load

⚠WARNING AC power within the cabinet and the rear side of the cabinet door presents a shock hazard that can cause severe personal injury or death. When the cabinet door is open, use extreme caution to avoid touching electrical contacts with body, tools, jewelry, clothes, hair, etc.

1. Check to see if the Genset Power Available LED on the control panel is lit.

If the Genset Power Available LED is not lit,

- a. Check the output voltage of the power source by observing the voltmeter on the generator set.
- b. Check the control setting to verify that the system nominal voltage matches what is listed on the nameplate.
- c. Check the control setting to verify that the system frequency matches what is listed on the nameplate.
- d. Check the control setting to verify that the system phase setting matches what is listed on the nameplate.

If the Genset Power Available LED is lit,

- a. The transfer time delay may not have expired. The TDNE can be set for up to 300 seconds. If you do not wish to wait until the time delay expires, press the Override pushbutton.

FUNCTION CODE FOR TDNE	VALUE CODE	VALUE (Default in bold italics)
○ ○ ○ ● ○	○ ○ ○	0 Seconds (Disabled)
	○ ○ ●	1 Second
	○ ● ○	2 Seconds
	○ ● ●	3 Seconds
	● ○ ○	5 Seconds
	● ○ ●	30 Seconds
	● ● ○	120 Seconds
	● ● ●	300 Seconds

- b. There may be an active transfer inhibit. If a transfer inhibit is enabled, the load transfer will not take place until the Override pushbutton on the control panel is pressed or the transfer inhibit input is disabled.

2. If the problem persists, call your dealer or distributor.

After Power Returns, the Transfer Switch Does Not Return To Normal Position

1. Check to see if the Utility Power Available LED is lit.

If the Utility Power Available LED is lit,

- a. The retransfer time delay period may not have expired. The TDEN can be set for up to 30 minutes. If you do not wish to wait until the time delay expires, press the Override pushbutton.

FUNCTION CODE FOR TDEN	VALUE CODE	VALUE (Default in bold italics)
○ ○ ○ ● ●	○ ○ ○	0 Minutes (Disabled)
	○ ○ ●	0.1 Minutes
	○ ● ○	5 Minutes
	○ ● ●	10 Minutes
	● ○ ○	15 Minutes
	● ○ ●	20 Minutes
	● ● ○	25 Minutes
	● ● ●	30 Minutes

- b. There may be an active retransfer inhibit. If a retransfer inhibit is enabled, the load transfer will not take place until the Override pushbutton on the control panel is pressed, the retransfer inhibit input is disabled, or the genset fails.
- c. There may be an active TDEL. Wait until the time delay has expired. The TDEL can be set for up to 300 seconds.

FUNCTION CODE FOR TDEL	VALUE CODE	VALUE (Default in bold italics)
○ ○ ● ● ○	○ ○ ○	0 Seconds (Disabled)
	○ ○ ●	1 Second
	○ ● ○	2 Seconds
	○ ● ●	3 Seconds
	● ○ ○	5 Seconds
	● ○ ●	30 Seconds
	● ● ○	120 Seconds
	● ● ●	300 Seconds

- d. A phase check may be enabled. When the phase check function is enabled, the utility does not assume the load until both sources are within acceptable limits of the phase check sensor.

If the Utility Power Available LED is not lit,

- a. Check the control setting to verify that the utility undervoltage dropout point is set lower than the pickup set point.
2. If the problem persists, call your dealer or distributor.

Generator Set Continues to Run After Retransfer of Load to Normal Power

⚠WARNING *AC power within the cabinet and the rear side of the cabinet door presents a shock hazard that can cause severe personal injury or death. When the cabinet door is open, use extreme caution to avoid touching electrical contacts with body, tools, jewelry, clothes, hair, etc.*

1. The engine cooldown time delay may not have expired. The TDEC can be set for up to 30 minutes.

FUNCTION CODE FOR TDEC	VALUE CODE	VALUE (Default in bold italics)
○ ○ ● ○ ○	○ ○ ○	0 Minutes (Disabled)
	○ ○ ●	0.1 Minutes
	○ ● ○	5 Minutes
	○ ● ●	10 Minutes
	● ○ ○	15 Minutes
	● ○ ●	20 Minutes
	● ● ○	25 Minutes
	● ● ●	30 Minutes

2. Stop the generator set with its Start/Stop switch. Call your dealer or distributor.

System Does Not Test With Load

⚠WARNING *AC power within the cabinet and the rear side of the cabinet door presents a shock hazard that can cause severe personal injury or death. When the cabinet door is open, use extreme caution to avoid touching electrical contacts with body, tools, jewelry, clothes, hair, etc.*

1. Check the control setting to verify that the Test With/Without Load function has been set to With Load.
2. If the control has been set to Test With Load,
 - a. The transfer time delay may not have expired. The TDNE can be set for up to 300 seconds. If you do not wish to wait until the

time delay expires, press the Override pushbutton.

FUNCTION CODE FOR TDNE	VALUE CODE	VALUE (Default in bold italics)
○ ○ ○ ● ○	○ ○ ○	0 Seconds (Disabled)
	○ ○ ●	1 Second
	○ ● ○	2 Seconds
	○ ● ●	3 Seconds
	● ○ ○	5 Seconds
	● ○ ●	30 Seconds
	● ● ○	120 Seconds
	● ● ●	300 Seconds

- b. There may be an active transfer inhibit. If a transfer inhibit is enabled, the load transfer will not take place until the Override pushbutton on the control panel is pressed or the transfer inhibit input is disabled.
- c. There may be an active TDEL. Wait until the time delay has expired. The TDEL can be set for up to 300 seconds.

FUNCTION CODE FOR TDEL	VALUE CODE	VALUE (Default in bold italics)
○ ○ ● ● ○	○ ○ ○	0 Seconds (Disabled)
	○ ○ ●	1 Second
	○ ● ○	2 Seconds
	○ ● ●	3 Seconds
	● ○ ○	5 Seconds
	● ○ ●	30 Seconds
	● ● ○	120 Seconds
	● ● ●	300 Seconds

- d. A phase check may be enabled. When the phase check function is enabled, the genset does not assume the load until both sources are within acceptable limits of the phase check sensor.

System Does Not Exercise With Load

⚠WARNING *AC power within the cabinet and the rear side of the cabinet door presents a shock hazard that can cause severe personal injury or death. When the cabinet door is open, use extreme caution to avoid touching electrical contacts with body, tools, jewelry, clothes, hair, etc.*

1. Check the control setting to verify that the Exercise With/Without Load function has been set to With Load.

2. If the control has been set to Exercise With Load,

- a. The transfer time delay may not have expired. The TDNE can be set for up to 300 seconds. If you do not wish to wait until the time delay expires, press the Override pushbutton.

FUNCTION CODE FOR TDNE	VALUE CODE	VALUE (Default in bold italics)
○ ○ ○ ● ○	○ ○ ○	0 Seconds (Disabled)
	○ ○ ●	1 Second
	○ ● ○	2 Seconds
	○ ● ●	3 Seconds
	● ○ ○	5 Seconds
	● ○ ●	30 Seconds
	● ● ○	120 Seconds
	● ● ●	300 Seconds

- b. There may be an active transfer inhibit. If a transfer inhibit is enabled, the load transfer will not take place until the Override pushbutton on the control panel is pressed or the transfer inhibit input is disabled.

- c. There may be an active TDEL. Wait until the time delay has expired. The TDEL can be set for up to 300 seconds.

FUNCTION CODE FOR TDEL	VALUE CODE	VALUE (Default in bold italics)
○ ○ ● ● ○	○ ○ ○	0 Seconds (Disabled)
	○ ○ ●	1 Second
	○ ● ○	2 Seconds
	○ ● ●	3 Seconds
	● ○ ○	5 Seconds
	● ○ ●	30 Seconds
	● ● ○	120 Seconds
	● ● ●	300 Seconds

- d. A phase check may be enabled. When the phase check function is enabled, the genset does not assume the load until both sources are within acceptable limits of the phase check sensor.

External Exercise Clock Does Not Start An Exercise

⚠WARNING *AC power within the cabinet and the rear side of the cabinet door presents a shock hazard that can cause severe personal injury or death. When the cabinet door is open, use extreme caution to avoid touching electrical contacts with body, tools, jewelry, clothes, hair, etc.*

1. Check the control setting to verify that the External Exercise function has been set to On.
2. Check the exercise program to see if exercise periods have been set up.
3. Check the exercise program to verify that both start and stop times for the exercise period have been set up. The exercise will not start if only the start time is set up.

External Exerciser Does Not Repeat an Exercise

Check the external exercise clock Permanent On/Off Mode setting. Exercises will not repeat if this feature is set to Off.

Battery Charger Fails To Charge (If Equipped)

Check the battery charger fuse(s). Replace, if necessary, with fuses of the correct rating. Fuse ampere ratings are shown on the charger faceplate.

⚠WARNING *Ignition of explosive battery gases can cause severe personal injury. Do not smoke or cause any spark or flame while servicing batteries.*

If the fuse is OK, call your dealer or distributor.

Battery Loses Water

The battery charger float voltage could be too high (if equipped with battery charger). If the problem continues, call your dealer or distributor.

Battery Loses Charge

Battery charger float voltage could be too low (if equipped with battery charger). If the problem continues, call your dealer or distributor.

TROUBLESHOOTING PROCEDURES FOR EXPERIENCED SERVICE PERSONNEL

This section describes a typical transfer switch sequence of events, and provides detailed troubleshooting procedures for experienced service personnel. The troubleshooting procedures use conditional schematics and symptoms to diagnose all possible problems.

⚠WARNING *Improper operation of the generator set presents a hazard that can cause severe personal injury or death. Observe all safety precautions in your generator set manuals.*

⚠WARNING *AC power within the cabinet and the rear side of the cabinet door presents a shock hazard that can cause severe personal injury or death. Use extreme caution to avoid touching electrical contacts with body, tools, jewelry, hair, clothes, etc. The following procedures are to be performed only by technically trained and experienced personnel.*

About Customer Inputs

In applications with remote customer inputs, the genset may start unexpectedly as a result of these inputs. These symptoms may appear to be caused by the transfer switch control. Verify that the remote input is not causing the symptom or isolate the control from these inputs before troubleshooting the control.

Control Panel LED Indicators

The control panel located on the transfer switch enclosure door contains six LED indicators. The indicators provide some information about the current control status and may be helpful in troubleshooting the transfer switch. See Figure 8-1, Table 8-1 and Table 8-2.

TROUBLESHOOTING

	PAGE
Sequence of Events	8-10
Troubleshooting With Symptoms	8-16
Utility Power Failure	8-17
Utility Power Is Restored	8-20
Miscellaneous Troubleshooting Issues	8-23

TABLE 8-2. CONTROL PANEL CONNECTIONS

CONNECTOR	PIN #	FUNCTION	TYPE	COMMENTS
P3 TS1311 Control for Transfer Switches with Line-to-Neutral Voltage Sensing	1	N Generator	Voltage Sensor Inputs	75–480 Volts AC
	3	L1 Generator		
	5	N Utility		
	7	L3 Utility		
	9	L2 Utility		
	11	L1 Utility		
P3 TS1310 Control for Transfer Switches with Line-to-Line Voltage Sensing	1	L3 Generator	Voltage Sensor Inputs	75–480 Volts AC
	3	L1 Generator		
	5	L3 Utility		
	7	L2 Utility		
	9	L1 Utility		
P4	1	Functional Earth Ground	Inputs	Common for remote inputs
	2	Remote Override		Connect to P4-1 to activate
	3	Remote Test		Connect to P4-1 to activate
	4	External Exerciser Clock		Connect to P4-1 to activate
	5	Transfer Inhibit		Connect to P4-1 to activate
	6	Retransfer Inhibit		Connect to P4-1 to activate
	7	Connected to Utility (Normal)		Connect to P4-1 to activate when connected to utility power
	8	Connected to Genset (Emergency)		Connect to P4-1 to activate when connected to the genset
P5	1	Open Normal (Utility)	Outputs	Grounded internally to energize open normal K4 relay
	2	Close Normal (Utility)		Grounded internally to energize close normal K2 relay
	3	Open Emergency (Genset)		Grounded internally to energize open emergency K1 relay
	4	Close Emergency (Genset)		Grounded internally to energize close emergency K3 relay
	5	Elevator Pretransfer		Grounded internally to energize elevator pretransfer relay
	6	Genset Start Relay		Internal dry contact closes (de-energizes) to start the genset and is held open (energized) to stop the genset
	7	Genset Start Relay		
	8	Ground Input (-)	Battery Connections	8–35 volts DC
	9	B+ Input		

NOTE: L3 Utility is not available on 2 pole transfer switches

SEQUENCE OF EVENTS

The control executes a prescribed sequence of events for all transfer switch operations.

Normal to Emergency Sequence of Events

The following describes the sequence of events for an GTEC transfer switch during a **normal (utility) power failure**. In this example, TDNE and TDPT are set higher than zero, TDEL is set to zero, and phase check is not enabled.

Steps 1 thru 8 describe what normally happens when the transfer switch is in the Normal position, utility power fails, and the switch transfers to the Neutral position (see Figure 8-2). Steps 9 thru 12 describe what then normally happens when the switch then moves from the Neutral position to the Emergency position (see Figure 8-3).

1. While the transfer switch is connected to the utility (Normal position), utility power fails. The Utility Connected LED remains lit but the Utility Power Available LED goes out.
2. The time delay engine start (TDES) begins.
3. When the TDES expires, the internal start contact closes P5-6 and P5-7, sending a start signal to the generator.
4. When the generator starts and produces power, the Genset Power Available LED lights.
5. A time delay normal to emergency (TDNE) begins.
6. After the TDNE expires, the control enables the Open Normal output by grounding P5-1, energizing the K4 relay coil.
7. The transfer switch moves to the Neutral position.
8. Auxiliary switch ASW1 removes the ground signal from P4-7, signaling that the ATS has disconnected from Normal; then the Utility Connected LED goes out.
9. The control starts the time delay programmed transition (TDPT) timer.
10. When the TDPT timer expires, both the Open Normal (P5-1) and Close Emergency (P5-4) outputs are grounded, energizing K3 and K4 relay coils to move the transfer switch from the Neutral position to the Emergency position. An auxiliary switch within the ATS breaks the signal.
11. The load is transferred to the generator.
12. Auxiliary switch BSW1 provides a ground signal to P4-8, signaling that the ATS has transferred; then the Genset Connected LED lights. The control then removes the ground signal from the Open Normal (P5-1) and Close Emergency (P5-4) outputs, de-energizing relays K3 and K4.

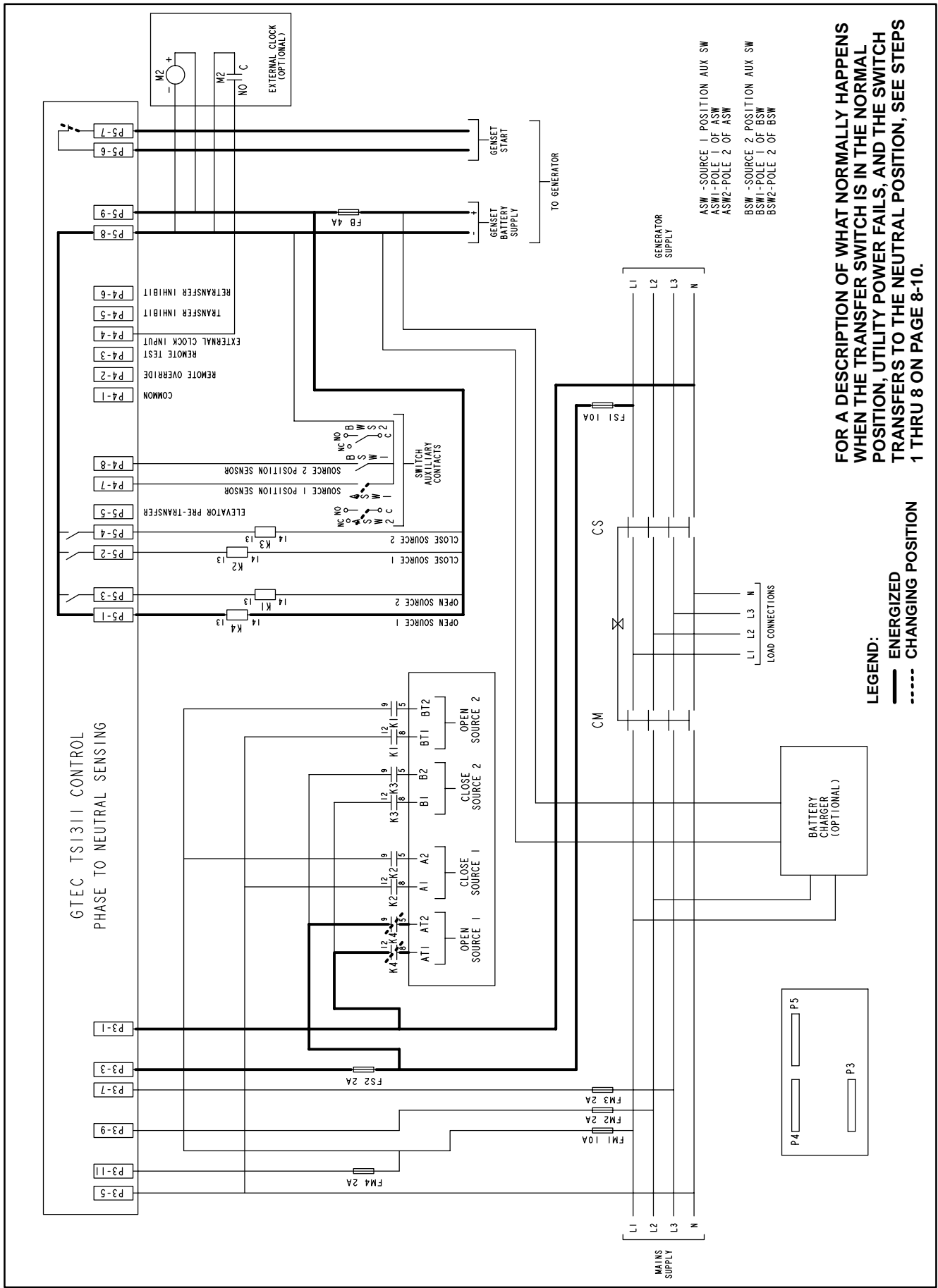

FOR A DESCRIPTION OF WHAT NORMALLY HAPPENS WHEN THE TRANSFER SWITCH IS IN THE NORMAL POSITION, UTILITY POWER FAILS, AND THE SWITCH TRANSFERS TO THE NEUTRAL POSITION, SEE STEPS 1 THRU 8 ON PAGE 8-10.

LEGEND:
 — ENERGIZED
 - - - - CHANGING POSITION

FIGURE 8-2. TYPICAL CONDITIONAL SCHEMATIC – LOSS OF UTILITY POWER OCCURS, TRANSFER FROM UTILITY (SOURCE 1) TO NEUTRAL

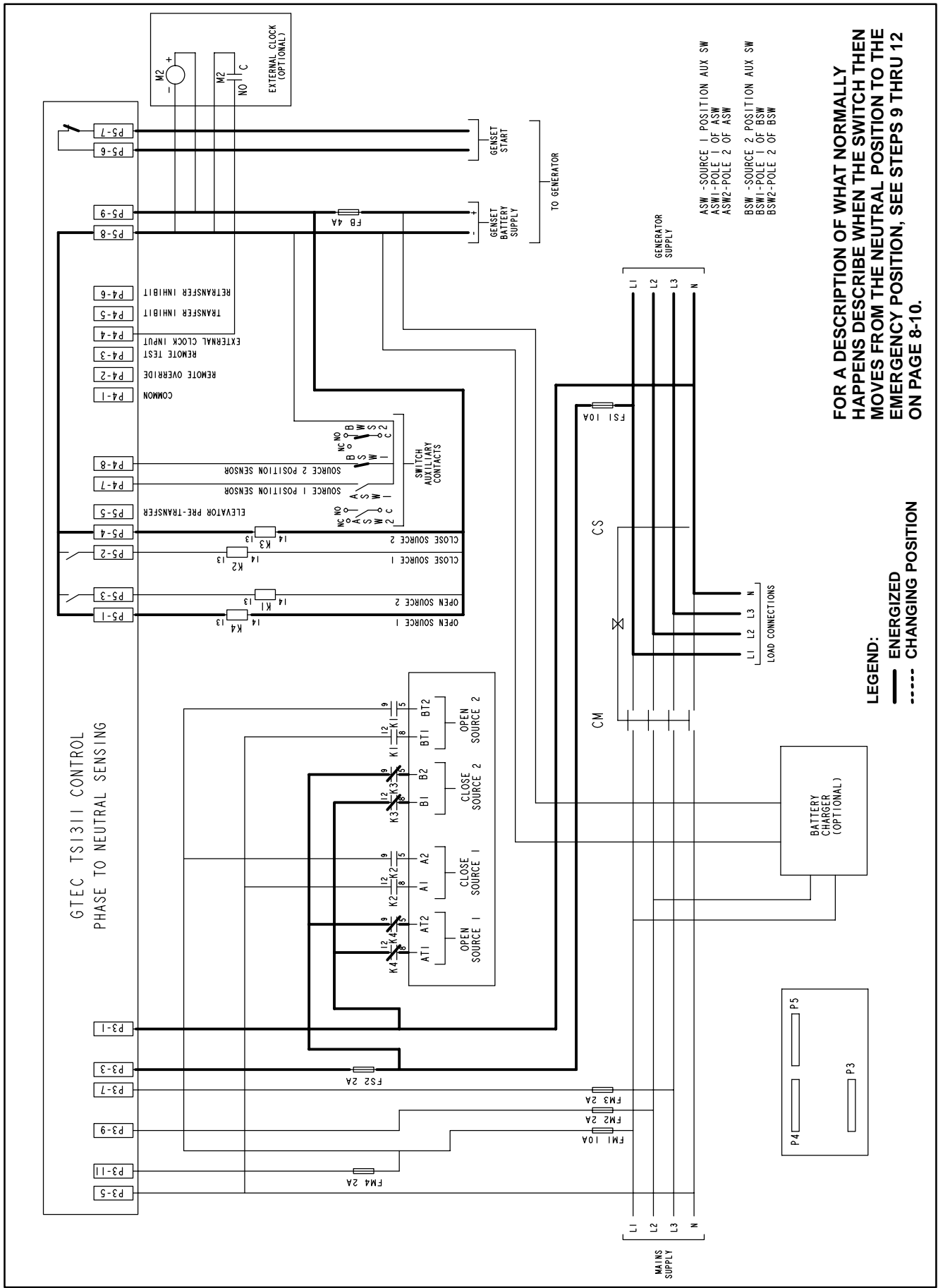

FIGURE 8-3. TYPICAL CONDITIONAL SCHEMATIC – GENSET (SOURCE 2) AVAILABLE, TRANSFER FROM NEUTRAL TO THE GENSET

Emergency to Normal Sequence of Events

The following describes the sequence of events for an GTEC transfer switch that occur after the load has been transferred to the genset and then utility power is restored. In this example, TDEN and TDPT are set higher than zero, TDEL is set to zero, and phase check is not enabled.

Steps 1 thru 5 describe what normally happens when the transfer switch is in the Emergency position (connected to the genset), utility power returns, and the switch transfers to the Neutral position (see Figure 8-4). Steps 6 thru 10 describe what then normally happens when the switch moves from the Neutral position to the Normal position (see Figure 8-5).

1. The utility returns. The Utility Power Available LED lights.
2. A time delay emergency to normal (TDEN) begins.
3. After the TDEN expires, the control grounds the Open Emergency output (P5-3), energizing K1 relay coil.
4. The transfer switch moves to the Neutral position.
5. Auxiliary switch BSW1 removes the ground signal from P4-8, signaling that the ATS has disconnected from Emergency; then the Genset Connected LED goes out.
6. The control starts the TDPT timer.
7. When the TDPT timer expires, the control grounds both the Open Emergency (P5-3) and Close Normal (P5-2) outputs, energizing K1 and K2 relay coils to move the transfer switch from the Neutral position to the Normal position. The load is transferred to the utility.
8. Auxiliary switch ASW1 provides a ground signal to P4-7, signaling that the ATS has transferred; then the Utility Connected LED lights. The control then removes the ground signal from the Open Emergency (P5-3) and Close Normal (P5-2) outputs, de-energizing relays K1 and K2.
9. The control starts the time delay engine cool-down (TDEC) timer.
10. When the TDEC timer expires, the P5-6 to P5-7 contact opens and the generator stops running and the Genset Power Available LED goes out.

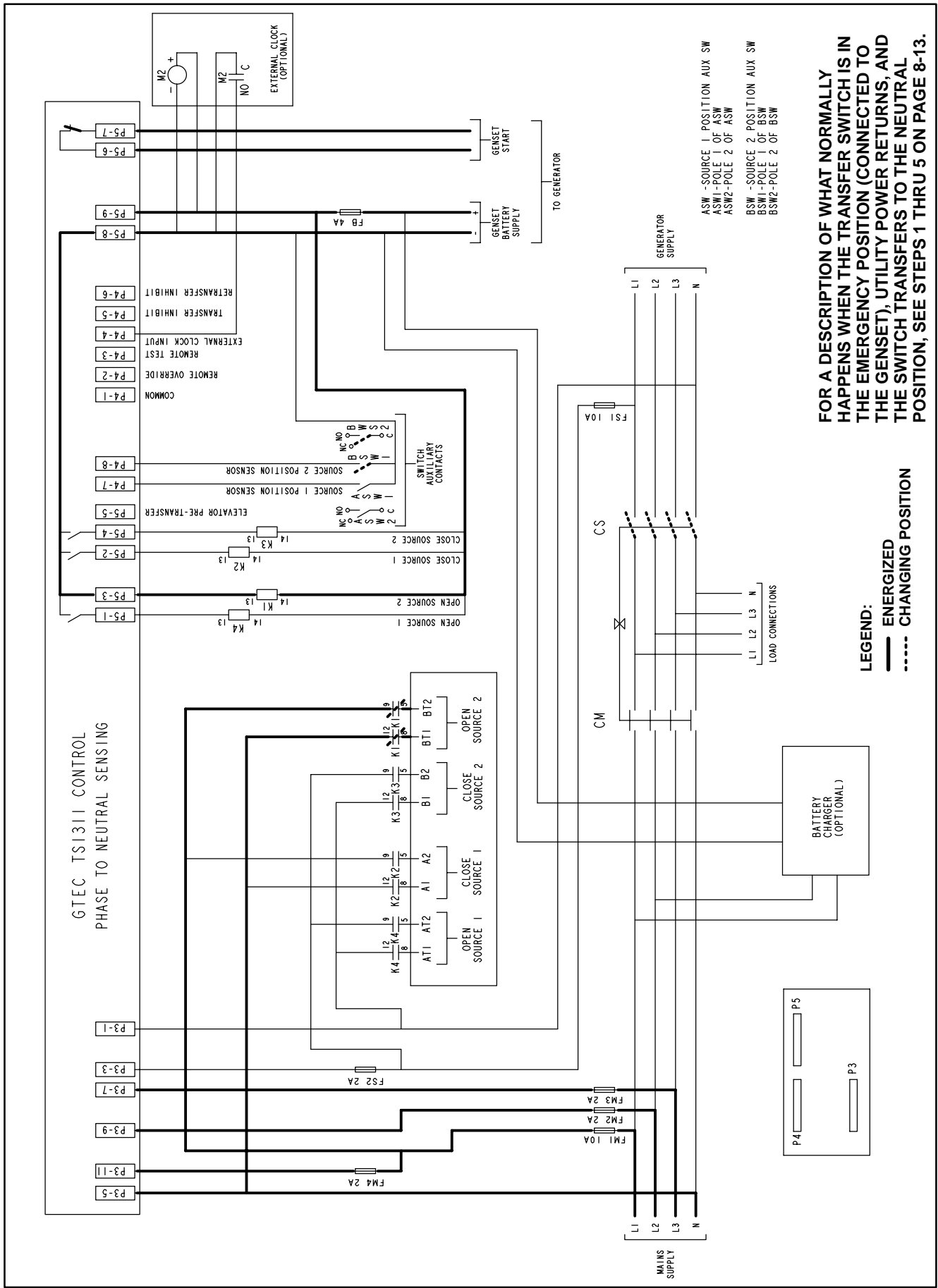
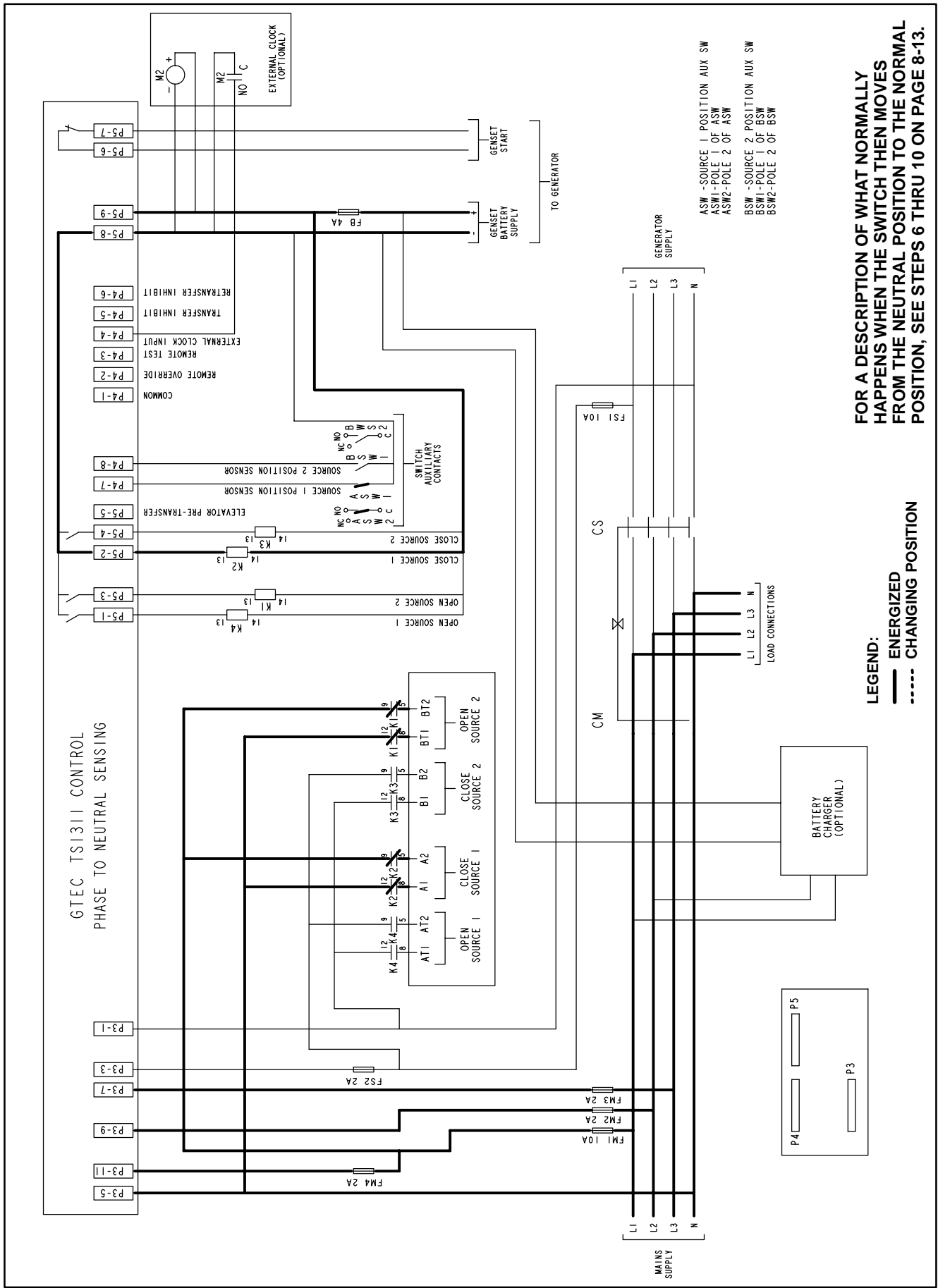

FIGURE 8-4. TYPICAL CONDITIONAL SCHEMATIC – UTILITY POWER RETURNS, TRANSFER FROM GENSET (SOURCE 2) TO NEUTRAL



FOR A DESCRIPTION OF WHAT NORMALLY HAPPENS WHEN THE SWITCH THEN MOVES FROM THE NEUTRAL POSITION TO THE NORMAL POSITION, SEE STEPS 6 THRU 10 ON PAGE 8-13.

LEGEND:
 — ENERGIZED
 ---- CHANGING POSITION

FIGURE 8-5. TYPICAL CONDITIONAL SCHEMATIC – UTILITY POWER AVAILABLE, TRANSFER FROM NEUTRAL TO UTILITY (SOURCE 1)

TROUBLESHOOTING WITH SYMPTOMS

Use the troubleshooting guide to help diagnose transfer switch problems. It is divided into sections based on the symptom. Common problems are listed with their possible causes. Refer to the corrective action column for the appropriate test or adjustment procedure. The section page number in the right column lists the location of the test or adjustment procedure in the manual.

NOTE: In the schematics shown in this section, “Source 1 Position” refers to the Normal position on the transfer switch which is connected to the utility power source. “Source 2 Position” refers to the Emergency position on the transfer switch which is connected to the generator set.

Conditional schematics are used to highlight the circuit that is energized during the sequence of the events. These conditional schematics are for a typical transfer switch with options. Always refer to the schematic and wiring diagram package that was shipped with the transfer switch for specific information about its configuration.

Make a thorough inspection of the transfer switch wiring to make sure that good wire harness and ground connections are made. Correct wiring problems before performing any test or replacing any components.

Transfer Switch Operation

When troubleshooting the GTEC transfer switch, it is important to remember the following:

- The control uses an auxiliary contact (ASW1 and BSW1) on either side of the switch to determine if the switch has opened or closed.

If the switch is bad, the control will continue to either open or close that side of the switch.

- The control supplies a grounding signal to pick up the control relays (K1, K2, K3, and K4).
- All inputs are activated by applying a ground to the signal input.
- The control operates over a DC voltage range of 8 to 35 volts but the control relays are voltage dependant (12 or 24 volts, depending on the genset start battery).
- If the switch is left connected to a DC power source (for example, the genset start battery) but there is no AC power available, the control panel Connected LED for that power source will still be lit.
- The transfer, retransfer, and program transition relays (K1, K2, K3, and K4) are pulsed and are powered for only one second, or until an auxiliary contact (ASW1 or BSW1) changes state, and then the power is removed (the relays are de-energized). When a relay is being energized, there is an audible click.
- The software includes a retry function. If the switch fails to transfer within one second, power is removed and the software waits ten seconds before trying again. After five attempts, the software quits trying and either the Utility Connected LED or the Genset Connected LED flashes, depending on which part of the switch circuit has failed. All operations are then locked out until the software is reset by pressing the Override pushbutton on the control panel.

UTILITY POWER FAILURE

TABLE 8-3. UTILITY POWER (SOURCE 1) FAILS BUT THE GENSET DOES NOT START

⚠WARNING *AC power within the cabinet and the rear side of the cabinet door presents a shock hazard that can cause severe personal injury or death. Use extreme caution to avoid touching electrical contacts with body, tools, jewelry, hair, clothes, etc. Prior to working with live circuits, remove all sources of AC power and remove power to the door by removing the fuse from the FB fuse block. The following procedures are to be performed only by technically trained and experienced personnel.*

⚠WARNING *Improper operation of the generator set presents a hazard that can cause severe personal injury or death. Observe all safety precautions in your generator set manuals.*

Problem	Possible Cause	Corrective Action	Section-Page
Genset cranks but does not start	There may be a genset problem.	Check the fuel system. Refer to the genset's service manual.	
Genset does not crank	<ol style="list-style-type: none"> 1. A time delay engine start (TDES) may be timing. 2. There may not be a genset start signal. 3. The genset may be waiting for a remote start command. 4. There may be defective wiring. 5. There may be a defective battery or cables. 6. The genset control may not be functioning correctly. 	<ol style="list-style-type: none"> 1. Wait until the time delay (up to 10 seconds) has expired, or press the Override pushbutton on the control panel, or ground the Override input. 2. Check for a genset start signal (closed contact between P5-6 and P5-7). 3. Verify that the genset control is set for Remote Start. 4a. Check the start circuit wiring (see Figure 8-2). 4b. Check the wiring between the ATS and the genset control. 5. Check the batteries and cable connections. 6. Check the genset control for proper operation. 	<p>4-1 4-4</p> <p>8-11</p>

TABLE 8-4. GENSET IS RUNNING BUT THE ATS DID NOT TRANSFER TO THE GENSET

⚠WARNING AC power within the cabinet and the rear side of the cabinet door presents a shock hazard that can cause severe personal injury or death. Use extreme caution to avoid touching electrical contacts with body, tools, jewelry, hair, clothes, etc. Prior to working with live circuits, remove all sources of AC power and remove power to the door by removing the fuse from the FB fuse block. The following procedures are to be performed only by technically trained and experienced personnel.

⚠WARNING Improper operation of the generator set presents a hazard that can cause severe personal injury or death. Observe all safety precautions in your generator set manuals.

Indicator	Possible Cause	Corrective Action	Section-Page
Genset Available LED is off	<ol style="list-style-type: none"> 1. There may be improper voltage at the voltage sensor inputs. 2. There may be improper voltage between the ATS power terminals. 3. There may be improper voltage at the genset output terminals. 	<ol style="list-style-type: none"> 1a. Check for proper genset voltage between P3-1 and P3-3. The voltage must be higher than the genset voltage sensor pickup point. 1b. Check voltage sensing wiring between the control and the ATS. 2. Check for proper genset voltage between ATS power terminals EA and EC (line-to-line) or between EA and EN (line-to-neutral). Voltage must be higher than the genset voltage sensor pickup point. 3a. Check for proper voltage at genset output terminals. Voltage must be higher than the genset voltage sensor pickup point. 3b. Check the power circuit wiring between the ATS and the genset. 	<p>4-7</p> <p>4-7</p>
Genset Available LED is on	<ol style="list-style-type: none"> 1. A time delay normal to emergency (TDNE) may be timing 2. There may be an active transfer inhibit. 3. A time delay elevator pre-transfer (TDEL) may be timing. 	<ol style="list-style-type: none"> 1. Wait until the time delay (up to 300 seconds) has expired, or press the Override pushbutton on the control panel, or ground the Override input. 2. Check for ground on P4-5. If present, remove the ground or press the Override pushbutton. 3. Check for a ground on P5-5. If present either remove the ground or else wait until the time delay (up to 300 seconds) has expired. 	<p>4-1</p> <p>4-4</p> <p>4-4</p> <p>4-2</p>

TABLE 8-4. GENSET IS RUNNING BUT THE ATS DID NOT TRANSFER TO THE GENSET (CONT.)

⚠WARNING AC power within the cabinet and the rear side of the cabinet door presents a shock hazard that can cause severe personal injury or death. Use extreme caution to avoid touching electrical contacts with body, tools, jewelry, hair, clothes, etc. Prior to working with live circuits, remove all sources of AC power and remove power to the door by removing the fuse from the FB fuse block. The following procedures are to be performed only by technically trained and experienced personnel.

⚠WARNING Improper operation of the generator set presents a hazard that can cause severe personal injury or death. Observe all safety precautions in your generator set manuals.

Indicator	Possible Cause	Corrective Action	Section-Page
Utility Connected LED is flashing	<p>The control was unsuccessful in its attempts to open the Normal side of the ATS. After 5 attempts to move the ATS, the Utility Connected LED flashes, indicating that it failed to open.</p> <p>To open Normal, the control grounds P5-1 to energize K4 for 1 second and monitors the Source 1 position input (P4-7) to see if auxiliary switch ASW1 opens. If ASW1 doesn't open, the control de-energizes K4, waits 10 seconds, and tries again. If ASW1 doesn't open after the fifth try, the Utility Connected LED flashes and the control quits trying.</p> <p>NOTE: The above description describes the operation if the programmed transition timer is set higher than zero. If TDPT is set to zero, the control grounds both the P5-1 and P5-4 outputs to energize the K3 and K4 relays to transfer the ATS to Emergency. If phase check is enabled, then both K3 and K4 are also energized but not until both sources are in phase.</p>	<ol style="list-style-type: none"> 1. Check the Open Normal circuit for a bad connection, open wire, or a faulty part. 2. Check K4 or the continuity through AT1 and AT2 or B1 and B2 of the ATS. 3. Press the Override pushbutton to reset the control so it will try to open the Normal side of the ATS. Observe what happens and verify that the relay coils are energizing. <ol style="list-style-type: none"> a. If the coils are energizing, <ul style="list-style-type: none"> – Check the wiring between the relays and the transfer switch. – Check to see if the transfer switch is faulty. b. The coils are not energizing, <ul style="list-style-type: none"> – Check the wiring between the relay and the control. – Check to see if the relay is faulty. 	4-4
Genset Connected LED is flashing	<p>The control was unsuccessful in its attempts to close the Emergency side of the ATS. After 5 attempts to move the ATS, the Genset Connected LED flashes, indicating that it failed to close.</p> <p>To close Emergency, the control grounds P5-1 and P5-4 to energize K3 and K4 for 1 second and monitors the Source 2 position input (P4-8) to see if auxiliary switch BSW1 closes. If BSW1 doesn't close, the control de-energizes K3 and K4, waits 10 seconds, and tries again. If BSW1 doesn't close after the fifth try, the Emergency Connected LED flashes and the control quits trying.</p>	<ol style="list-style-type: none"> 1. Check the Close Emergency circuit for a bad connection, open wire, or faulty part. 2. Check K3, K4, or the continuity through B1 and B2 of the ATS. 3. Press the Override pushbutton to reset the control so it will try to close the Emergency side of the ATS. Observe what happens and verify that the relay coils are energizing. <ol style="list-style-type: none"> a. If the coils are energizing, <ul style="list-style-type: none"> – Check the wiring between the relays and the transfer switch. – Check to see if the transfer switch is faulty. b. If the coils are not energizing, <ul style="list-style-type: none"> – Check the wiring between the relay and the control. – Check to see if the relay is faulty. 	4-4

UTILITY POWER IS RESTORED

TABLE 8-5. UTILITY POWER IS RESTORED BUT THE SWITCH DOES NOT TRANSFER TO NORMAL

<p>⚠WARNING AC power within the cabinet and the rear side of the cabinet door presents a shock hazard that can cause severe personal injury or death. Use extreme caution to avoid touching electrical contacts with body, tools, jewelry, hair, clothes, etc. Prior to working with live circuits, remove all sources of AC power and remove power to the door by removing the fuse from the FB fuse block. The following procedures are to be performed only by technically trained and experienced personnel.</p> <p>⚠WARNING Improper operation of the generator set presents a hazard that can cause severe personal injury or death. Observe all safety precautions in your generator set manuals.</p>			
Indicator	Possible Cause	Corrective Action	Section-Page
Utility Power Available LED is off	1. There may be improper voltage at the voltage sensor inputs.	1. Check for proper utility voltage between P3-5, P3-7, and P3-9 (line-to-line) or between P3-5, P3-7, P3-9 and P3-11 (line-to-neutral). Voltage must be higher than the utility voltage sensor pickup point. <ul style="list-style-type: none"> a. Check voltage sensing wiring between the control and the ATS. b. Make sure the utility voltage sensing pickup setting and dropout setting aren't both set at 90%. 	4-7, 5-3
	2. There may be improper utility voltage between the ATS power terminals.	2a. Check for proper utility power between ATS power terminals NA, NB, and NC. Voltage must be higher than the utility voltage sensor pickup point. 2b. Check power circuit wiring between the ATS and the upstream circuit breaker.	4-7
Utility Power Available LED is on	1. A time delay emergency to normal (TDEN) may be timing.	1. Wait until the time delay (up to 30 minutes) has expired, or press the Override pushbutton on the control panel, or ground the Override input.	4-1
	2. There may be an active retransfer inhibit input.	2. Check for ground on P4-6. If present, remove the ground or press the Override pushbutton.	4-4
	3. A TDEL may be timing.	3. Check for a ground on P5-5. If present, either remove the ground or else wait until the time delay (up to 300 seconds) has expired.	4-2
	4. A Phase Check may be enabled and the sources are not in phase.	4a. Check phase rotation 4b. Check frequency differences between the two sources. Frequency differences must be 1 Hz or less. 4c. Both sources may be at the exact same frequency but not in phase. The phase angle difference between the sources must be 25 degrees or less. Enable the "Returned to Programmed Transition" function. If the sources don't meet the requirements of in-phase for 2 minutes, then the control will transfer the ATS in the programmed transition mode.	

TABLE 8-5. UTILITY POWER IS RESTORED BUT THE SWITCH DOES NOT TRANSFER TO NORMAL (CONT.)

⚠WARNING AC power within the cabinet and the rear side of the cabinet door presents a shock hazard that can cause severe personal injury or death. Use extreme caution to avoid touching electrical contacts with body, tools, jewelry, hair, clothes, etc. Prior to working with live circuits, remove all sources of AC power and remove power to the door by removing the fuse from the FB fuse block. The following procedures are to be performed only by technically trained and experienced personnel.

⚠WARNING Improper operation of the generator set presents a hazard that can cause severe personal injury or death. Observe all safety precautions in your generator set manuals.

Indicator	Possible Cause	Corrective Action	Section-Page
Genset Connected LED is flashing	<p>The control was unsuccessful in its attempts to open the Emergency side of the ATS. After 5 attempts to move the ATS, the Emergency Connected LED flashes, indicating that it failed to open.</p> <p>To open Emergency, the control grounds P5-3 to energize K1 for 1 second and monitors the Source 2 position input (P4-8) to see if auxiliary switch BSW1 opens. If BSW1 doesn't open, the control de-energizes K1, waits 10 seconds, and tries again. If BSW1 doesn't open after the fifth try, the Genset Connected LED flashes and the control quits trying.</p> <p>NOTE: The above description describes the operation if the programmed transition timer is set higher than zero. If TDPT is set to zero, the control grounds both the P5-2 and P5-3 outputs to energize the K1 and K2 relays to transfer the ATS to Normal. If phase check is enabled, then both K1 and K2 are also energized but not until both sources are in phase.</p>	<ol style="list-style-type: none"> 1. Check the Open Emergency circuit for a bad connection, open wire, or a faulty part. 2. Check K1 or the continuity through BT1 and BT2 of the ATS. 3. Press the Override pushbutton to reset the control so it will try to open the Emergency side of the ATS. Observe what happens and verify that the relay coils are energizing. <ol style="list-style-type: none"> a. If the coils are energizing, <ul style="list-style-type: none"> – Check the wiring between the relays and the transfer switch. – Check to see if the transfer switch is faulty. b. If the coils are not energizing, <ul style="list-style-type: none"> – Check the wiring between the relay and the control. – Check to see if the relay is faulty. 	<p>8-14</p> <p>4-4</p>
Utility Connected LED is flashing	<p>The control was unsuccessful in its attempts to close the Normal side of the ATS. After 5 attempts to move the ATS, the Utility Connected LED flashes, indicating that it failed to close.</p> <p>To close Normal, the control grounds P5-2 and P5-3 to energize K1 and K2 for 1 second and monitors the Source 1 position input (P4-7) to see if auxiliary switch ASW1 closes. If ASW1 doesn't close, the control de-energizes K1 and K2, waits 10 seconds, and tries again. If ASW1 doesn't close after the fifth try, the Utility Connected LED flashes and the control quits trying.</p>	<ol style="list-style-type: none"> 1. Check the Close Normal circuit for a bad connection, open wire, or faulty part. 2. Check K1, K2, or the continuity through A1 and A2 of the ATS. 3. Press the Override pushbutton to reset the control so it will try to close the Normal side of the ATS. Observe what happens and verify that the relay coils are energizing. <ol style="list-style-type: none"> a. If the coils are energizing, <ul style="list-style-type: none"> – Check the wiring between the relays and the transfer switch. – Check to see if the transfer switch is faulty. b. If the coils are not energizing, <ul style="list-style-type: none"> – Check the wiring between the relay and the control. – Check to see if the relay is faulty. 	<p>8-15</p> <p>4-4</p>

TABLE 8-6. SWITCH TRANSFERRED TO NORMAL BUT THE GENSET CONTINUES TO RUN

⚠WARNING *AC power within the cabinet and the rear side of the cabinet door presents a shock hazard that can cause severe personal injury or death. Use extreme caution to avoid touching electrical contacts with body, tools, jewelry, hair, clothes, etc. Prior to working with live circuits, remove all sources of AC power and remove power to the door by removing the fuse from the FB fuse block. The following procedures are to be performed only by technically trained and experienced personnel.*

⚠WARNING *Improper operation of the generator set presents a hazard that can cause severe personal injury or death. Observe all safety precautions in your generator set manuals.*

Problem	Possible Cause	Corrective Action	Section-Page
Genset did not shut down after the ATS has transferred to Normal position	<ol style="list-style-type: none"> 1. A time delay engine cooldown (TDEC) may be timing. 2. The genset may not have received a stop signal. 	<ol style="list-style-type: none"> 1. Wait for the time delay (up to 30 minutes) to expire. 2. Check for a genset stop signal (open contact between P5-6 and P5-7). 	4-1
	<ol style="list-style-type: none"> 3. The selector switch on generator set control panel may not be in the correct position. 4. There may be defective wiring. 5. The genset control may not be operating correctly. 	<ol style="list-style-type: none"> 3. Check to see if the genset control is set for Remote Start. 4. Check the start circuit wiring (see Figure 8-4). 5. Check the genset control for proper operation. 	8-14

MISCELLANEOUS TROUBLESHOOTING ISSUES

TABLE 8-7. MISCELLANEOUS

⚠WARNING AC power within the cabinet and the rear side of the cabinet door presents a shock hazard that can cause severe personal injury or death. Use extreme caution to avoid touching electrical contacts with body, tools, jewelry, hair, clothes, etc. Prior to working with live circuits, remove all sources of AC power and remove power to the door by removing the fuse from the FB fuse block. The following procedures are to be performed only by technically trained and experienced personnel.

⚠WARNING Improper operation of the generator set presents a hazard that can cause severe personal injury or death. Observe all safety precautions in your generator set manuals.

Problem	Possible Cause	Corrective Action	Section-Page
Genset running for no apparent reason	<ol style="list-style-type: none"> 1. The genset may not have received a stop signal. 2. The selector switch on generator set control panel may not be in the correct position. 3. There may be defective wiring. 4. The genset control may not be operating correctly. 	<ol style="list-style-type: none"> 1. Check for a genset stop signal (open contact between P5-6 and P5-7). 2. Check to see if the genset control is set for Remote Start. 3. Check the start circuit wiring (see Figure 8-4). 4. Check the genset control for proper operation. 	8-14
Front panel test doesn't transfer the load	1. The control is not set to Test With Load.	1. Check the control setting to verify that the Test With/Without Load function has been set to With Load.	4-5
	2. The control is set to Test With Load but one of the following has occurred.	2. If the control has been set to Test With Load,	
	a. The transfer time delay may not have expired.	a. The TDNE can be set for up to 300 seconds. If you do not wish to wait until the time delay expires, press the Override pushbutton.	4-1 4-4
	b. There may be an active transfer inhibit.	b. Check for ground on P4-5. If a transfer inhibit is enabled, the load transfer will not take place until the Override pushbutton on the control panel is pressed or the transfer inhibit input is disabled.	4-4
c. There may be an active TDEL.	c. Check for a ground on P5-5. If present, either remove the ground or else wait until the time delay has expired. The TDEL can be set for up to 300 seconds.	4-2	
d. A phase check may be enabled.	d. When the phase check function is enabled, the genset does not assume the load until both sources are within acceptable limits of the phase check sensor.	4-7	

TABLE 8-7. MISCELLANEOUS (CONT.)

⚠WARNING AC power within the cabinet and the rear side of the cabinet door presents a shock hazard that can cause severe personal injury or death. Use extreme caution to avoid touching electrical contacts with body, tools, jewelry, hair, clothes, etc. Prior to working with live circuits, remove all sources of AC power and remove power to the door by removing the fuse from the FB fuse block. The following procedures are to be performed only by technically trained and experienced personnel.

⚠WARNING Improper operation of the generator set presents a hazard that can cause severe personal injury or death. Observe all safety precautions in your generator set manuals.

Problem	Possible Cause	Corrective Action	Section-Page
Remote test doesn't function	There is no contact between TB1-5 and TB1-8.	Close the contact to start a test.	
Unit did not exercise.	<ol style="list-style-type: none"> 1. The selector switch on generator set control panel may not be in the correct position. 2. Although the optional external exerciser is installed, the External Exercise function may not be set to On. 3. An exercise period may not be set or is set but not yet started. 4. There may be genset problems. 	<ol style="list-style-type: none"> 1. Verify that the operation selector switch on the generator set control panel is set to the Remote position. 2. If the optional external exerciser is installed, enter Configuration Mode and verify that the External Exercise function on the control panel has been set to On. 3. Check the Exercise LED on the control panel to see if it is lit. <ol style="list-style-type: none"> a. If the Exercise LED is not lit, no exercise period has been set. Refer to the exerciser programming procedure for information on setting an exercise. b. If the Exercise LED is lit but not flashing, the exercise period has not yet started. Integrated exercisers do not display exercise start and stop times. If the optional external exerciser is enabled, check the exercise clock to see when an exercise is scheduled. 4. Try starting the generator set using its start-stop controls. If it does not crank, check the starting batteries and cable connections. If it cranks but does not start, check the fuel supply. 	<p>4-8, 5-3, 5-4</p> <p>4-8</p> <p>4-14</p>

9. Transfer Switch Service

This section covers the removal and replacement procedures for the transfer switch assembly.

SWITCH ASSEMBLY REMOVAL/REPLACEMENT PROCEDURE

There are separate switch assemblies. Each assembly corresponds to a particular current range, and coil operating voltage, and number of poles. There are six current ranges (63 amperes, 100–125 amperes, 160–250 amperes, 300–500 amperes, 630–800 amperes, and 1000–1250 amperes) and three coil voltages (110, 220, and 277 VAC). Transfer switches can be in 2, 3, or 4 pole configurations.

For servicing purposes, each transfer switch assembly is removed and replaced as a unit. There are no serviceable components.

SWITCH REMOVAL AND REPLACEMENT PROCEDURE

Disconnect AC Power

⚠WARNING *The transfer switch presents a shock hazard that can cause severe personal injury or death unless all AC power is removed. Disconnect all sources of AC power to the transfer switch before servicing. Be sure to set the generator set operation selector switch to Stop, disconnect the battery charger from its AC power source, and disconnect the starting battery negative [–] cable.*

1. Turn the operation selector switch on the generator to Stop. (The selector switch is located on the generator set control panel.)
2. Disconnect all sources of AC power from the transfer switch.
3. Disconnect the battery charger, if present, from its AC power source and disconnect the set starting battery negative [–] cable.

Transfer Switch Assembly Removal

1. Open the transfer switch cabinet door.
2. Remove all control and power wiring from the switch terminals.
3. Loosen and remove the four screws, nuts, and washers that secure the switch panel and switch to the rear wall of the cabinet (see Figure 9-1).
4. Lift out the switch and panel assembly and set it aside.
5. Remove the switch from the mounting panel.

Transfer Switch Replacement

1. Install the new switch on the mounting panel.
2. Lift the switch and panel assembly and place the assembly into the cabinet and hang it on the studs on the rear wall. Install the four nuts and washers. Torque the nuts per Table 9-1.
3. Reconnect all control and power wiring.
4. Close the transfer switch door.

TABLE 9-1. METRIC HARDWARE TORQUES

Stud Size	Recommended Torque (N•m)
M5	2
M6	4
M8	9
M10	20
M12	35
M16	84
M20	165
M24	283

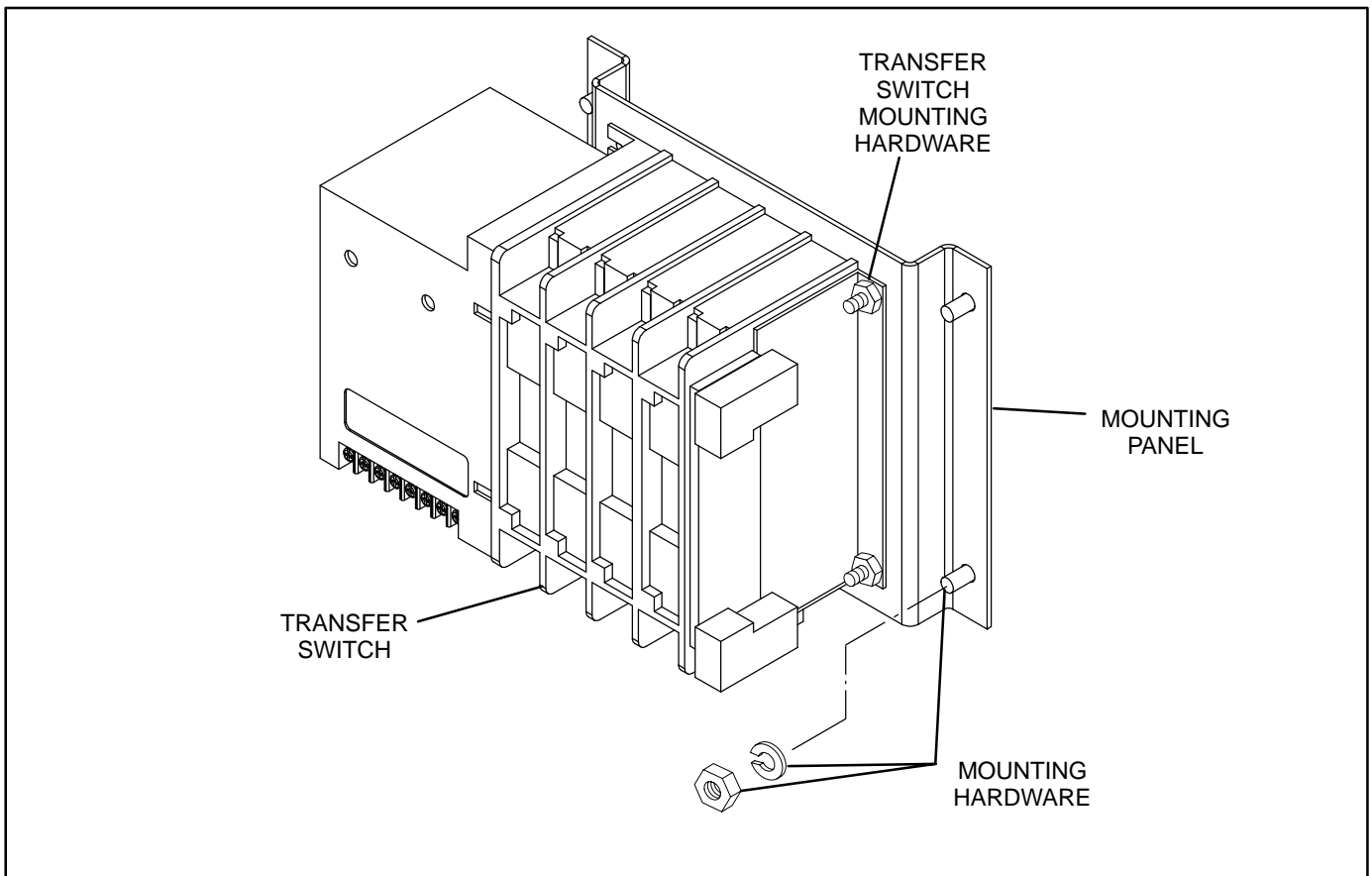

FIGURE 9-1. TRANSFER SWITCH REMOVAL

Reconnecting AC Power (When Finished)

1. Connect the negative (-) battery cable to the starting battery. If present, connect the battery charger to its AC power source.
2. Reconnect utility power (Normal) and genset power (Emergency).

3. Set the operation selector switch on the genset to in the Remote position.

⚠WARNING *AC power within the cabinet and the rear side of the cabinet door presents a shock hazard that can cause severe personal injury or death. Use extreme caution to avoid touching electrical contacts whenever the cabinet door is open.*

10. Parts Information

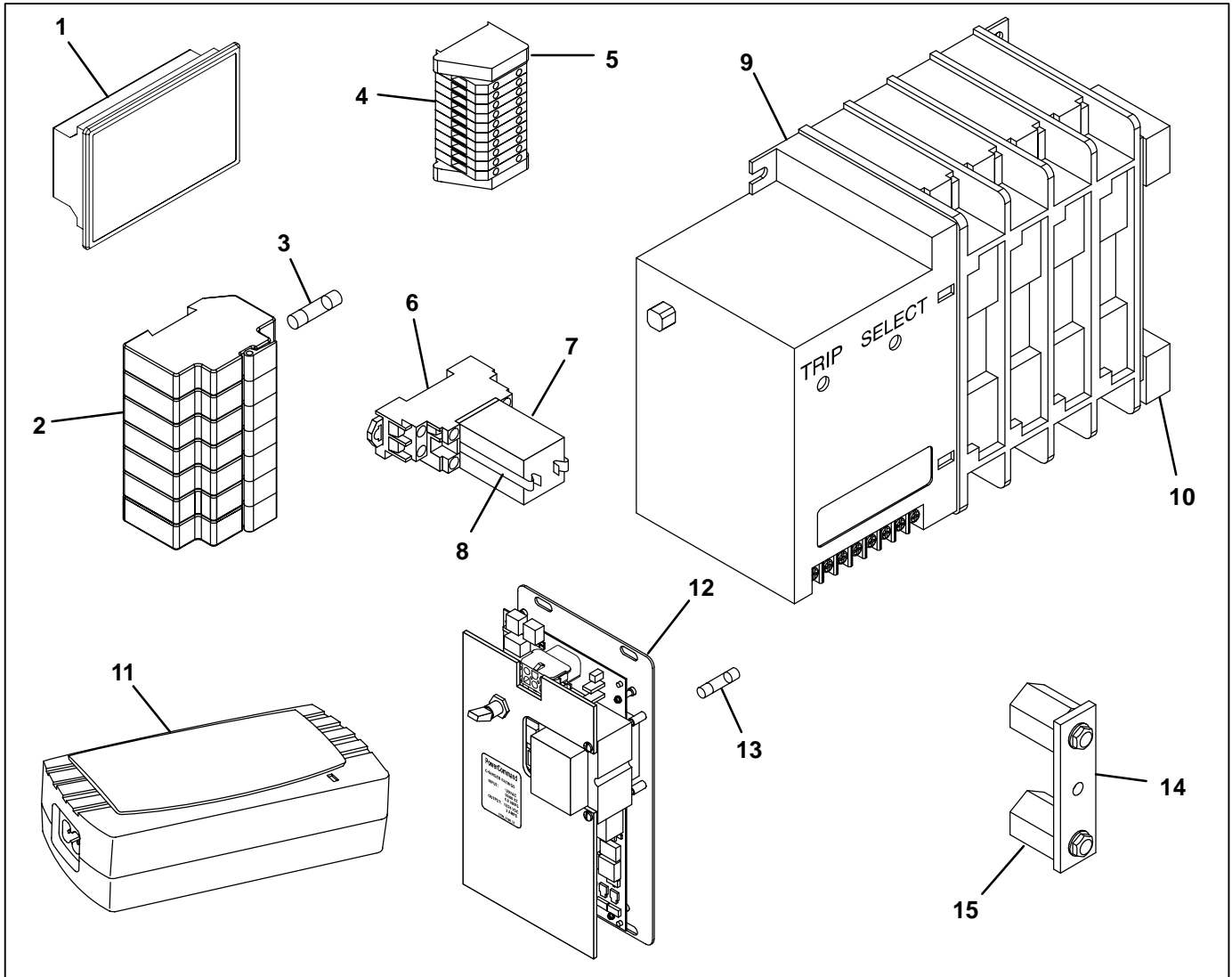

FIGURE 10-1. GTEC TRANSFER SWITCH PARTS

REF NO.	PART NO.	QTY USED	PART DESCRIPTION	REF NO.	PART NO.	QTY USED	PART DESCRIPTION
1			Control Display	2	321-0418	1	Fuse Block (Includes Fuses – Item 3)
			Line-to-Line Voltage Sensing (TS1310)	3			Fuse
	300-5965	1	Cabinet Construction with PowerCommand		321-0417-01	4	2 Amp
	300-5975	1	Open Construction without PowerCommand		321-0417-02	1	4 Amp
			Line-to-Neutral Voltage Sensing (TS1311)		321-0417-03	2	10 Amp
				4	332-3125-02	1	Terminal Block (TB1, 10 Poles)
				5	332-2878	2	Terminal End Bracket
	300-5985	1	Cabinet Construction with PowerCommand	6	307-3076	4	Base, Relay (Socket)
				7			Relay
	300-5986	1	Open Construction without PowerCommand		307-3070	4	12 VDC
					307-3071	4	24 VDC
				8	307-3077	8	Bracket, Relay (Clip)

GTEC Transfer Switch Parts

REF NO.	PART NO.	QTY USED	PART DESCRIPTION	REF NO.	PART NO.	QTY USED	PART DESCRIPTION
9			Transfer Switch Assembly (Includes item 10)				800 Amp
			63 Amp				Two Pole
			Two Pole				110 VAC
			110 VAC		306-5014-01	1	220 VAC
			220 VAC		306-5014-02	1	277 VAC
			277 VAC		306-5014-03	1	Three Pole
			Three Pole				110 VAC
			110 VAC		306-4983-01	1	220 VAC
			220 VAC		306-4983-02	1	277 VAC
			277 VAC		306-4983-03	1	Four Pole
			Four Pole				110 VAC
			110 VAC		306-4984-01	1	220 VAC
			220 VAC		306-4984-02	1	277 VAC
			277 VAC		306-4984-03	1	1250 Amp
			Four Pole				Two Pole
			110 VAC				110 VAC
			220 VAC		306-5015-01	1	220 VAC
			277 VAC		306-5015-02	1	277 VAC
			Three Pole		306-5015-03	1	Three Pole
			110 VAC				110 VAC
			220 VAC		306-4985-01	1	220 VAC
			277 VAC		306-4985-02	1	277 VAC
			Three Pole		306-4985-03	1	Four Pole
			110 VAC				110 VAC
			220 VAC		306-4986-01	1	220 VAC
			277 VAC		306-4986-02	1	277 VAC
			Four Pole		306-4986-03	1	Auxiliary Switch Level
			110 VAC				Battery Charger – 2 Amp,
			220 VAC	10	308-1217	2	12 VDC (100-240 VAC)
			277 VAC	11			24 VDC (100-240 VAC)
			250 Amp				Premium Battery Charger –
			Two Pole				2 Amp, 12/24 VDC
			110 VAC				(Includes item 13)
			220 VAC				120 VAC
			277 VAC		300-6000-01	1	208 VAC
			Three Pole		300-6000-02	1	240 VAC
			110 VAC		300-6000-03	1	277 VAC
			220 VAC		300-6000-04	1	380 VAC
			277 VAC		300-6000-05	1	416 VAC
			Four Pole		300-6000-06	1	480 VAC
			110 VAC		300-6000-07	1	Fuse, Battery Charger
			220 VAC	13	321-0298	1	(5 Amp, 250V)
			277 VAC				Neutral Bus Bar
			500 Amp				63 and 125 Amp Transfer
			Two Pole				Switches
			110 VAC		337-2366	1	250 and 500 Amp Transfer
			220 VAC		337-3760	1	Switches
			277 VAC		337-3761	1	800 and 1250 Amp Transfer
			Three Pole				Switches
			110 VAC				Isolator Standoff
			220 VAC				63 and 125 Amp Transfer
			277 VAC	15	332-2370	2	Switches
			Four Pole				250 and 500 Amp Transfer
			110 VAC				Switches
			220 VAC		332-2512	2	800 and 1250 Amp Transfer
			277 VAC		332-2512	4	Switches

11. Outline Drawings and Wiring Diagrams

SCHEMATIC	PAGE
Figure 11-1. IP32 Control Box Outline Drawing 300–6004 (63–125 Amperes)	11-3
Figure 11-2. IP32 Control Box Outline Drawing 300–6005 (200–500 Amperes)	11-4
Figure 11-3. IP32 Control Box Outline Drawing 300–6006 (630–1250 Amperes)	11-5
Figure 11-4. IP54 Control Box Outline Drawing 500–4559 (63–125 Amperes)	11-6
Figure 11-5. IP54 Control Box Outline Drawing 500–4560 (200–500 Amperes)	11-7
Figure 11-6. IP54 Control Box Outline Drawing 500–4561 (630–1250 Amperes)	11-8
Figure 11-7. Typical Open Construction for Transfer Switches	11-9
Figure 11-8. Transfer Switch Wiring Diagram 630–2993 (Phase to Neutral Sensing)	11-10
Figure 11-9. Transfer Switch Wiring Diagram 630–2930 (Phase to Phase Sensing)	11-12
Figure 11-10. Transfer Switch Small Cabinet Assembly Drawing 300–6055	11-14
Figure 11-11. Transfer Switch Medium Cabinet Assembly Drawing 300–6056	11-15
Figure 11-12. Transfer Switch Large Cabinet Assembly Drawing 300–6057	11-16

THIS PAGE LEFT INTENTIONALLY BLANK

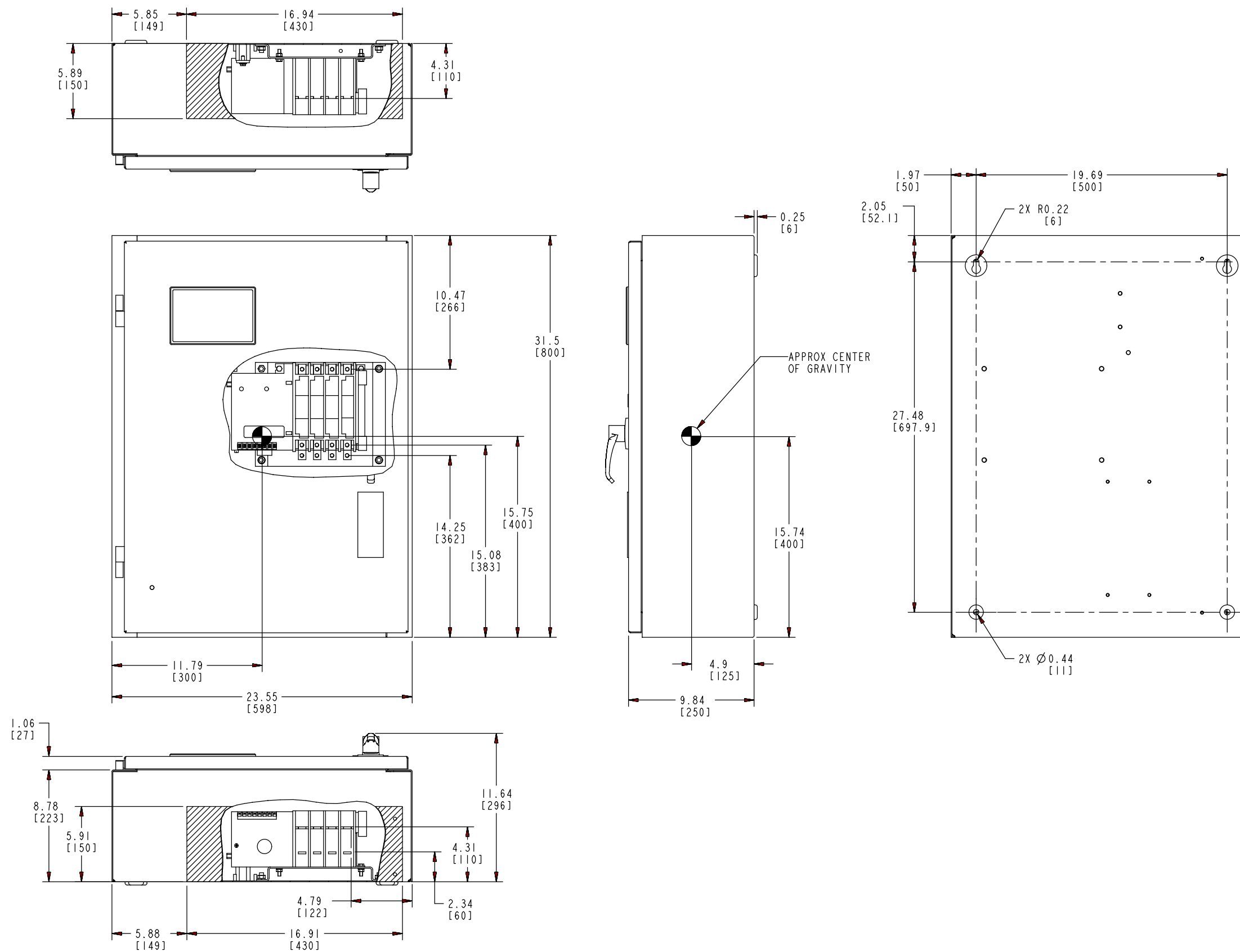

NOTE:

1. CABINET TYPE: IP32
2. APPROX WEIGHT: 48 KG (106 lbs)
3. DIMENSIONS IN () ARE MILLIMETERS.
4. USE SEPARATE CONDUITS FOR CONTROL WIRING & POWER WIRING. DO NOT COMBINE.
5. SHADED AREA INDICATES WIRING & CABLE ENTRANCE AREA. DO NOT INSTALL OUTSIDE OF SHADED AREA.

No. 300-6004 Sh 1 of 1
 Rev. A Sys: Pro-E
 Modified 6/2005

FIGURE 11-1. IP32 CONTROL BOX OUTLINE DRAWING (63-125 AMPS)

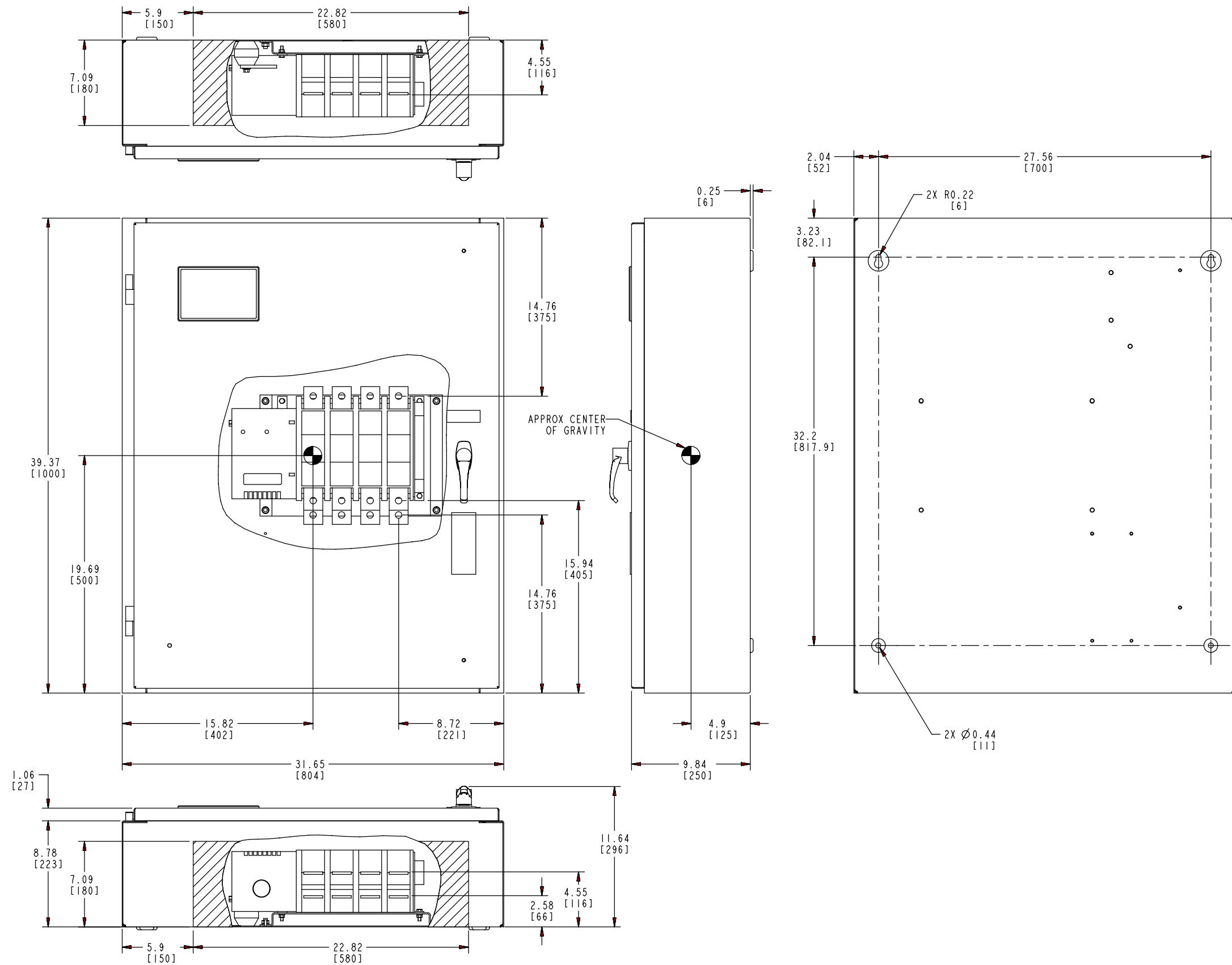

- NOTE:
1. CABINET TYPE: IP32
 2. APPROX WEIGHT: 65 KG (143 lbs)
 3. DIMENSIONS IN () ARE MILLIMETERS.
 4. USE SEPARATE CONDUITS FOR CONTROL WIRING & POWER WIRING. DO NOT COMBINE.
 5. SHADED AREA INDICATES WIRING & CABLE ENTRANCE AREA. DO NOT INSTALL OUTSIDE OF SHADED AREA.

No. 300-6005 Sh 1 of 1
 Rev. A Sys: Pro-E
 Modified 6/2005

FIGURE 11-2. IP32 CONTROL BOX OUTLINE DRAWING (200-500 AMPS)

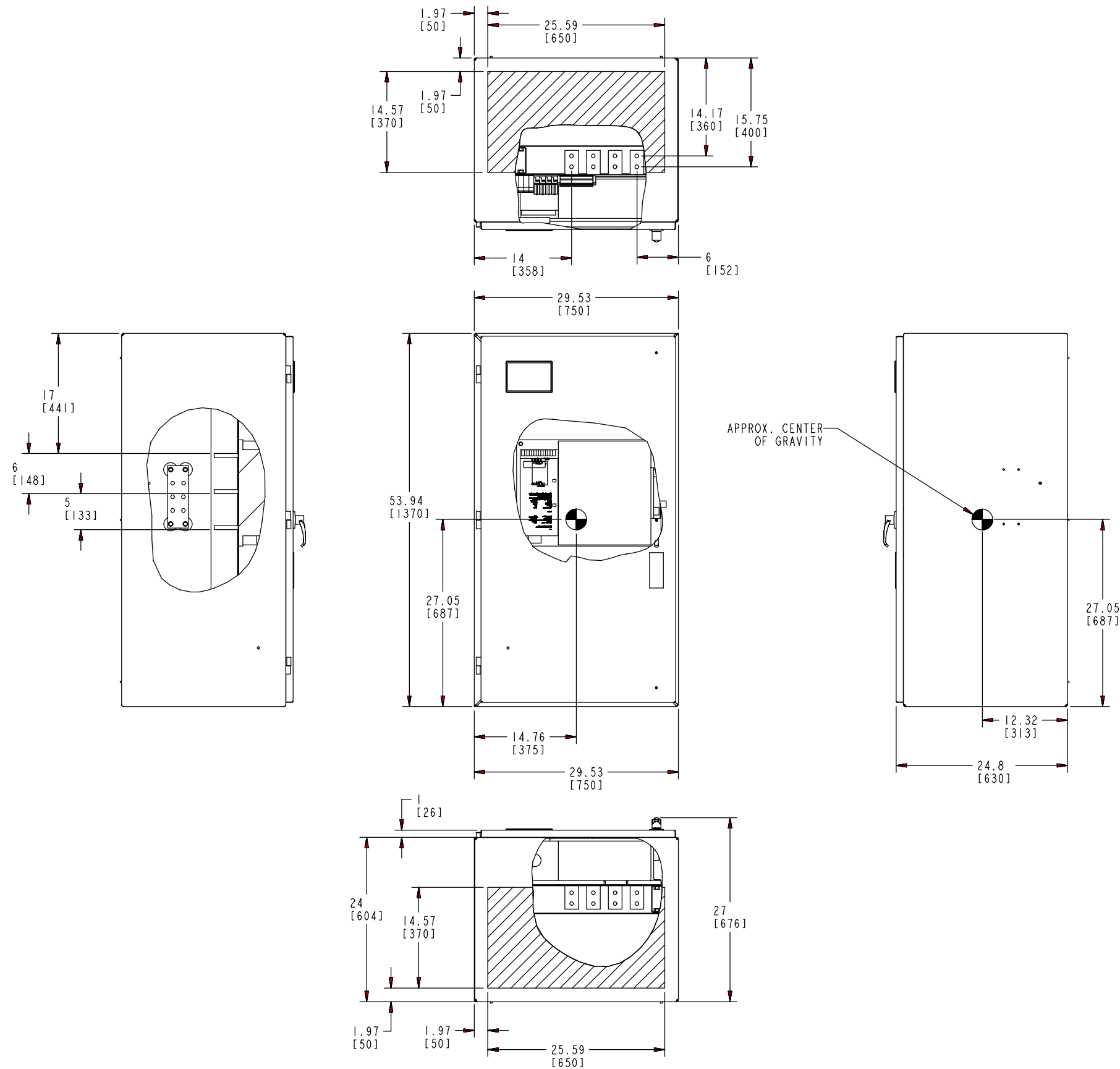

NOTE:

1. CABINET TYPE: IP32
2. APPROX WEIGHT: 184 KG (406 lbs)
3. DIMENSIONS IN [] ARE MILLIMETERS.
4. USE SEPARATE CONDUITS FOR CONTROL WIRING & POWER WIRING. DO NOT COMBINE.
5. SHADED AREA INDICATES WIRING & CABLE ENTRANCE AREA. DO NOT INSTALL OUTSIDE OF SHADED AREA.

No. 300-6006 Sh 1 of 1
 Rev. A Sys: Pro-E
 Modified 6/2005

FIGURE 11-3. IP32 CONTROL BOX OUTLINE DRAWING (630-1250 AMPS)

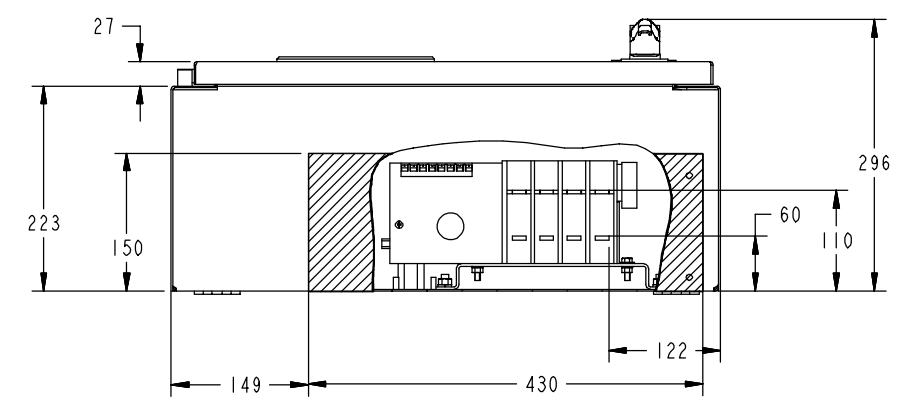
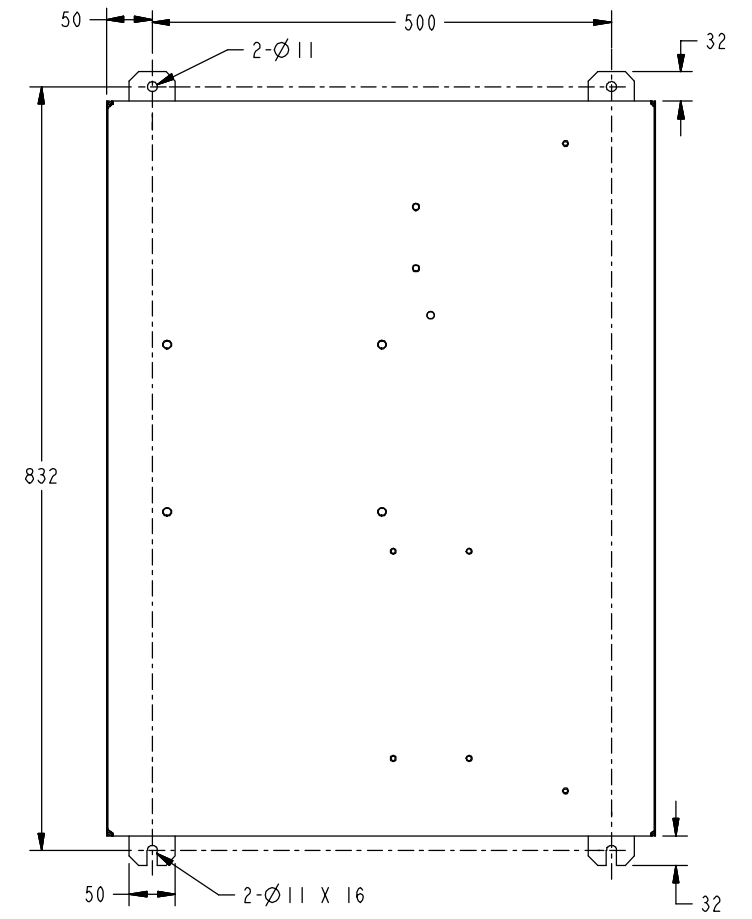
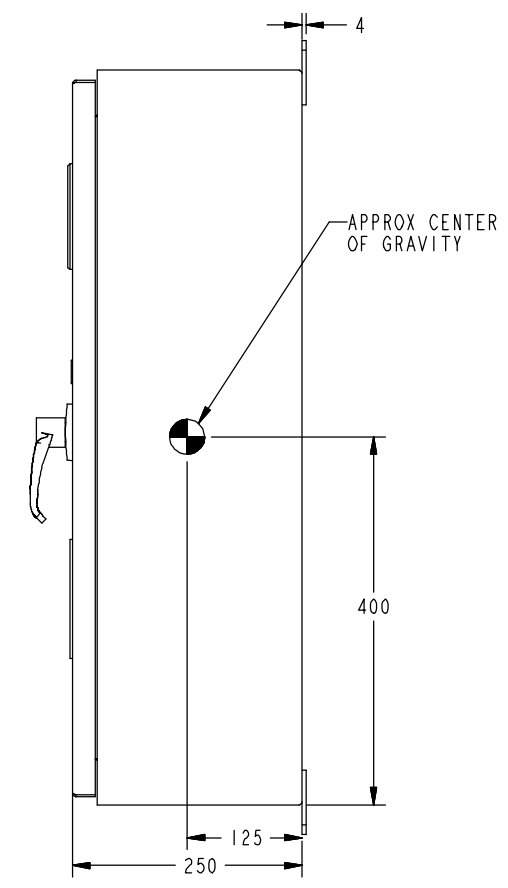
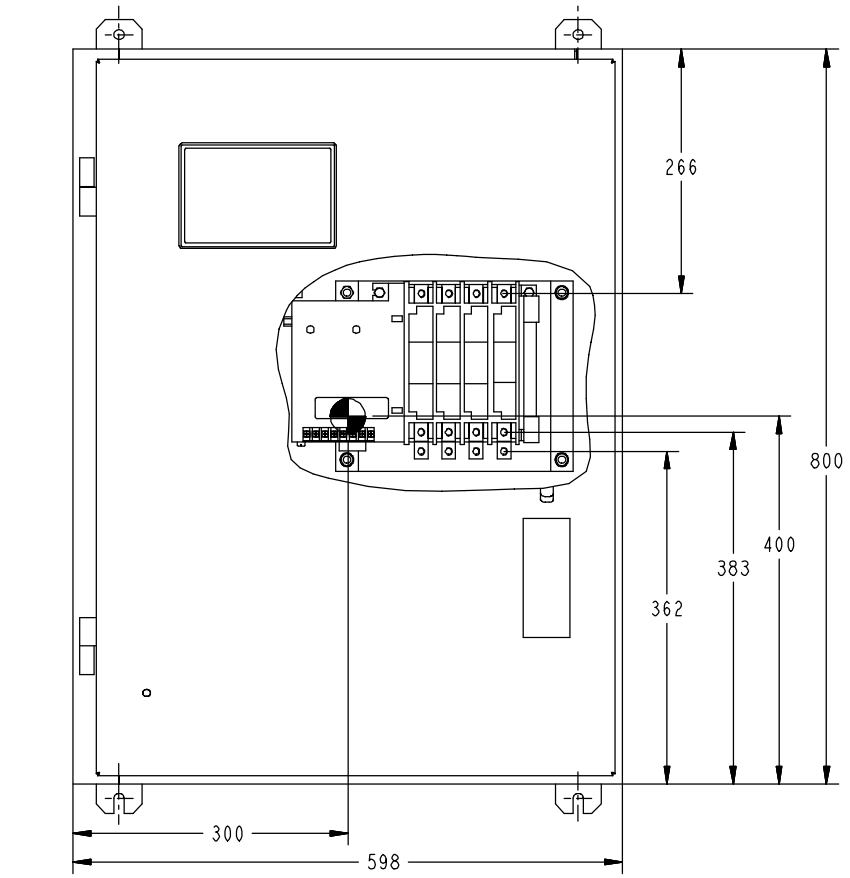
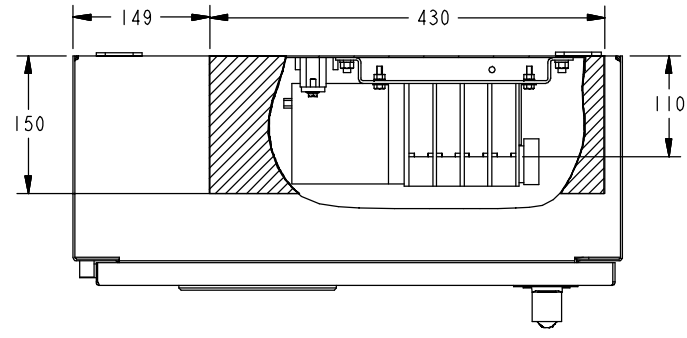

- NOTES:
1. CABINET TYPE: IP54
 2. AMPERAGE SIZE: 63 AMP THROUGH 125 AMP
 3. APPROXIMATELY WEIGHT: 50 KG
 4. USE SEPARATE CONDUITS FOR CONTROL WIRING & POWER WIRING. DO NOT COMBINE.
 5. SHADED AREA INDICATES WIRING & CABLE ENTRANCE AREA.

No. 500-4559 Sh 1 of 1
 Rev. A Sys: Pro-E
 Modified 5/2006

FIGURE 11-4. IP54 CONTROL BOX OUTLINE DRAWING (63-125 AMPS)

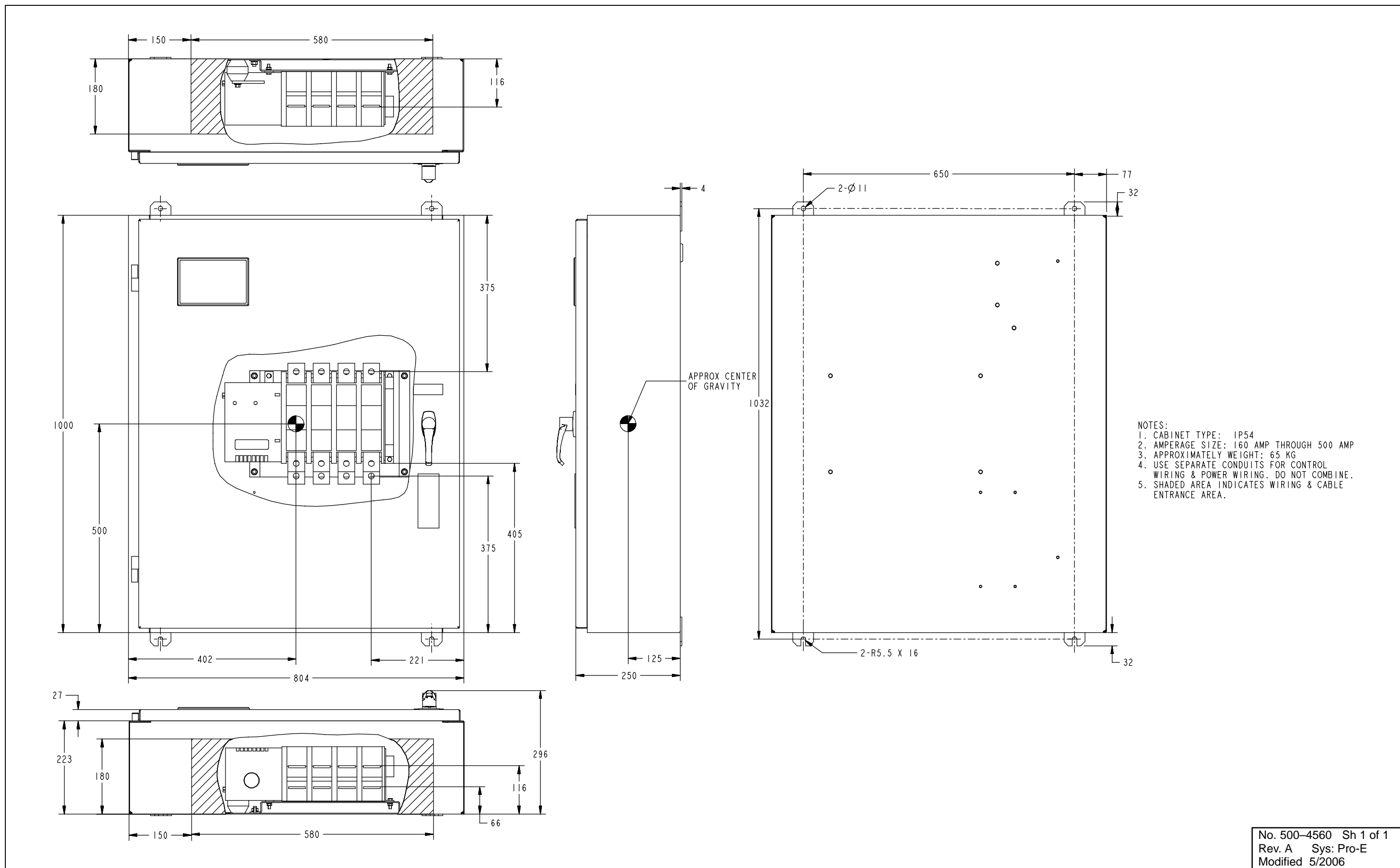
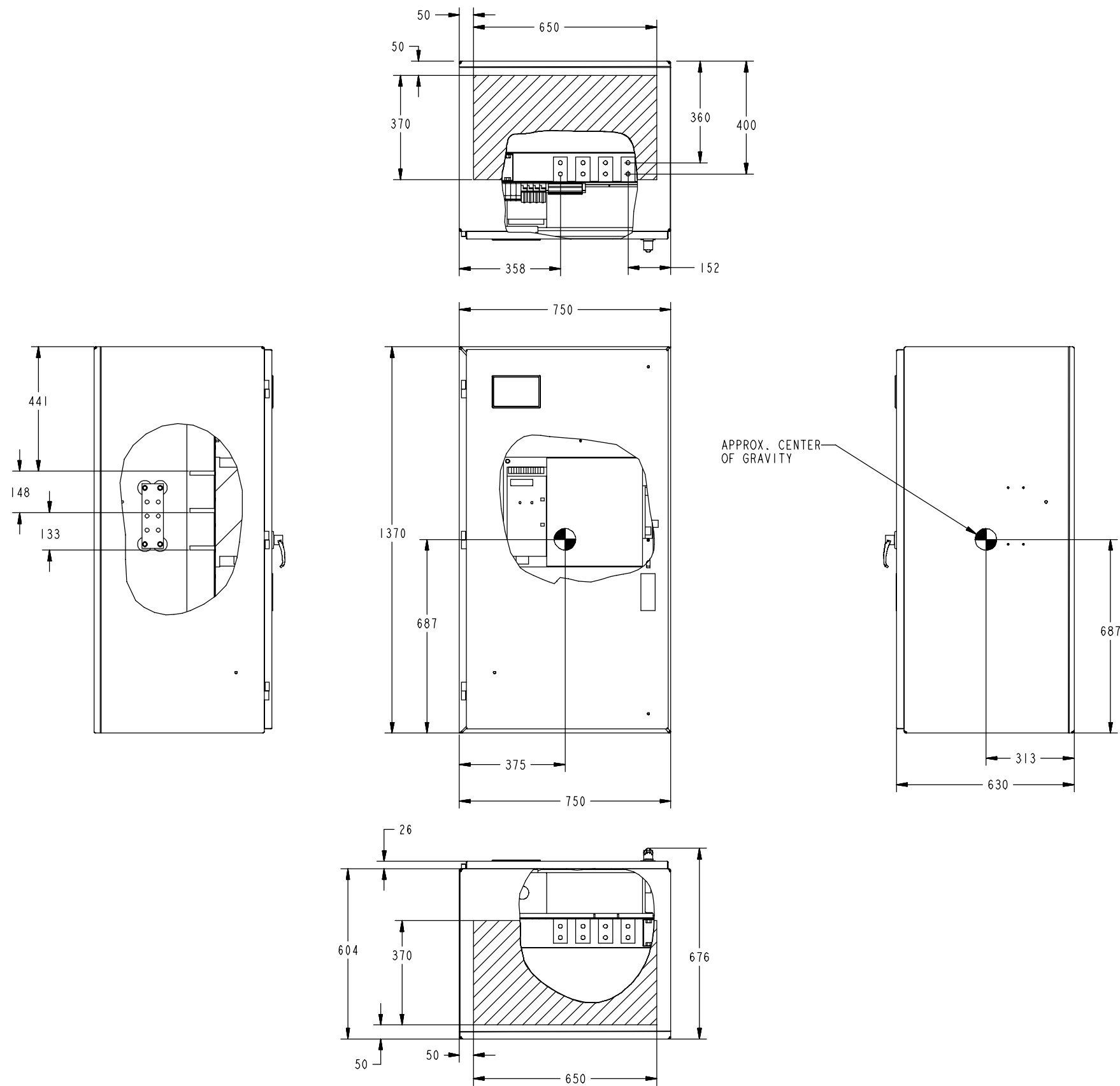

FIGURE 11-5. IP54 CONTROL BOX OUTLINE DRAWING (200-500 AMPS)



- NOTES:
1. CABINET TYPE: IP54
 2. AMPERAGE SIZE: 630 AMP THROUGH 1250 AMP
 3. APPROXIMATELY WEIGHT: 188 KG
 4. USE SEPARATE CONDUITS FOR CONTROL WIRING & POWER WIRING. DO NOT COMBINE.
 5. SHADED AREA INDICATES WIRING & CABLE ENTRANCE AREA. DO NOT INSTALL OUTSIDE OF SHADED AREA.

No. 500-4561 Sh 1 of 1
 Rev. A Sys: Pro-E
 Modified 5/2006

FIGURE 11-6. IP54 CONTROL BOX OUTLINE DRAWING (630-1250 AMPS)

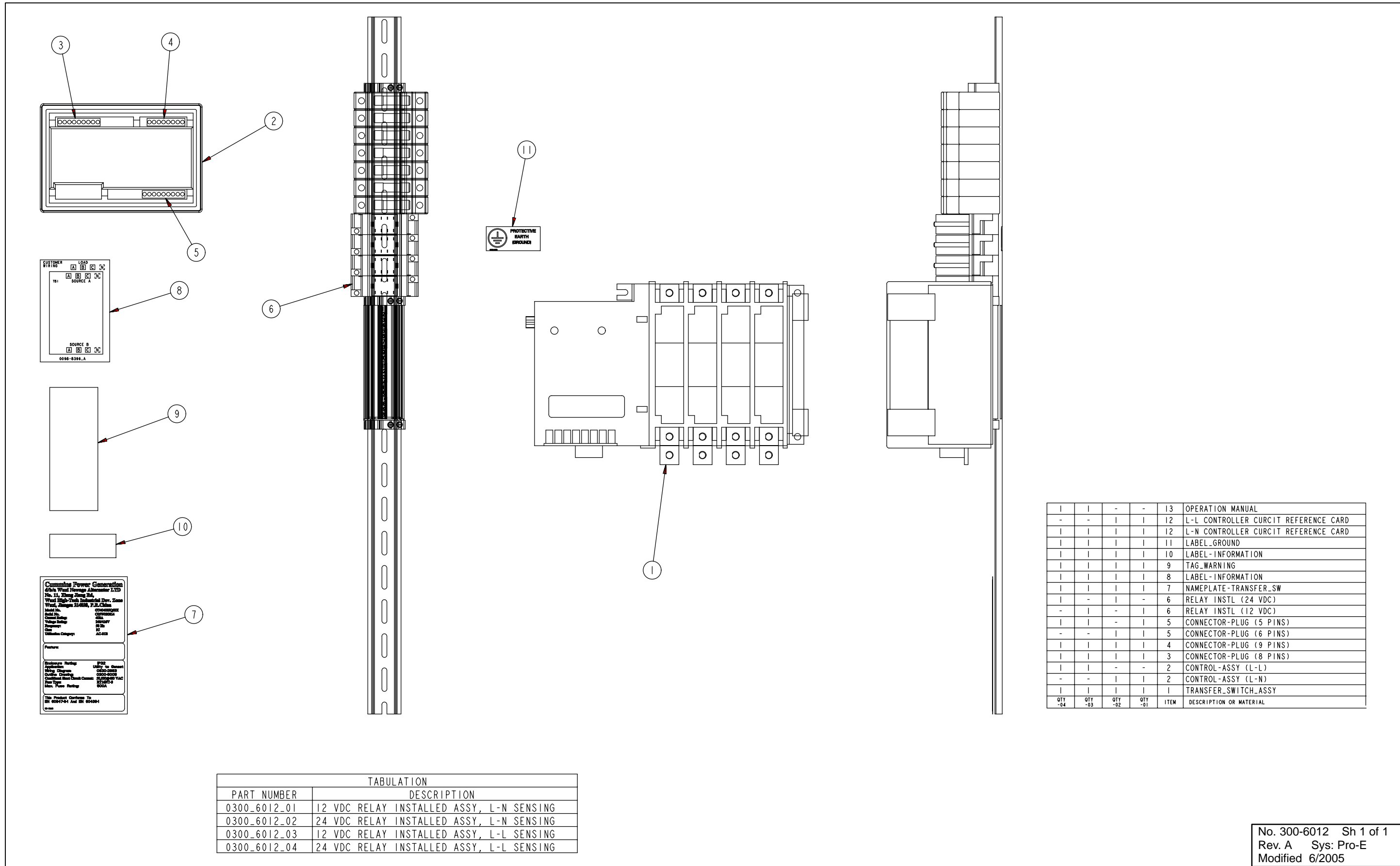

FIGURE 11-7. TYPICAL OPEN CONSTRUCTION TRANSFER SWITCH

THIS IS A REPRESENTATIVE (GENERIC) SCHEMATIC/WIRING DIAGRAM. FOR TROUBLESHOOTING, REFER TO THE SCHEMATIC AND WIRING DIAGRAM PACKAGE THAT WAS SHIPPED WITH THE TRANSFER SWITCH.

- NOTE:
1. WIRING IN 0.5sq.mm. MIN. UNLESS OTHERWISE STATED. 'A' SIZE IN 1.0 sq.mm. MIN.
 2. ALL COMPONENTS CODED IN ACCORDANCE WITH THIS DRAWING.
 3. CONTROL SIGNALS TO MAINS AND STANDBY SWITCHES TO BE SELECTED ACCORDING TO SYSTEM AND COIL VOLTAGES EITHER L-N OR L-L.
 4. ALL COMPONENTS SHOWN IN DE-ENERGIZED POSITION.
 5. GROUND WIRES SHALL BE GREEN WITH YELLOW STRIPE.
 6. M2-EXERCISER CLOCK AND BATTERY CHARGER ARE OPTIONAL.
 7. ALL WIRES SHALL HAVE IDENTIFICATION AT EACH END THAT SHOWS WHERE EACH RESPECTIVE END IS CONNECTED.
 8. ASW -SOURCE 1 POSITION AUX SW
ASW1-POLE 1 OF ASW
ASW2-POLE 2 OF ASW

BSW -SOURCE 2 POSITION AUX SW
BSW1-POLE 1 OF BSW
BSW2-POLE 2 OF BSW

POLE 2 USED FOR CUSTOMER CIRCUITS
 9. FOR SINGLE PHASE, 3 WIRE OPERATION, CONNECT WIRE FROM FM2 (MAINS LINE 2) TO P3-7.
 10. PREMIUM BATTERY CHARGER SHOWN CONNECTED LINE-TO-LINE. PREMIUM BATTERY CHARGER MAY ALSO BE CONNECTED LINE TO NEUTRAL TO SUIT ITS RATING. BATTERY CHARGER ONLY APPLIED ON LINE TO NEUTRAL CONNECTION.

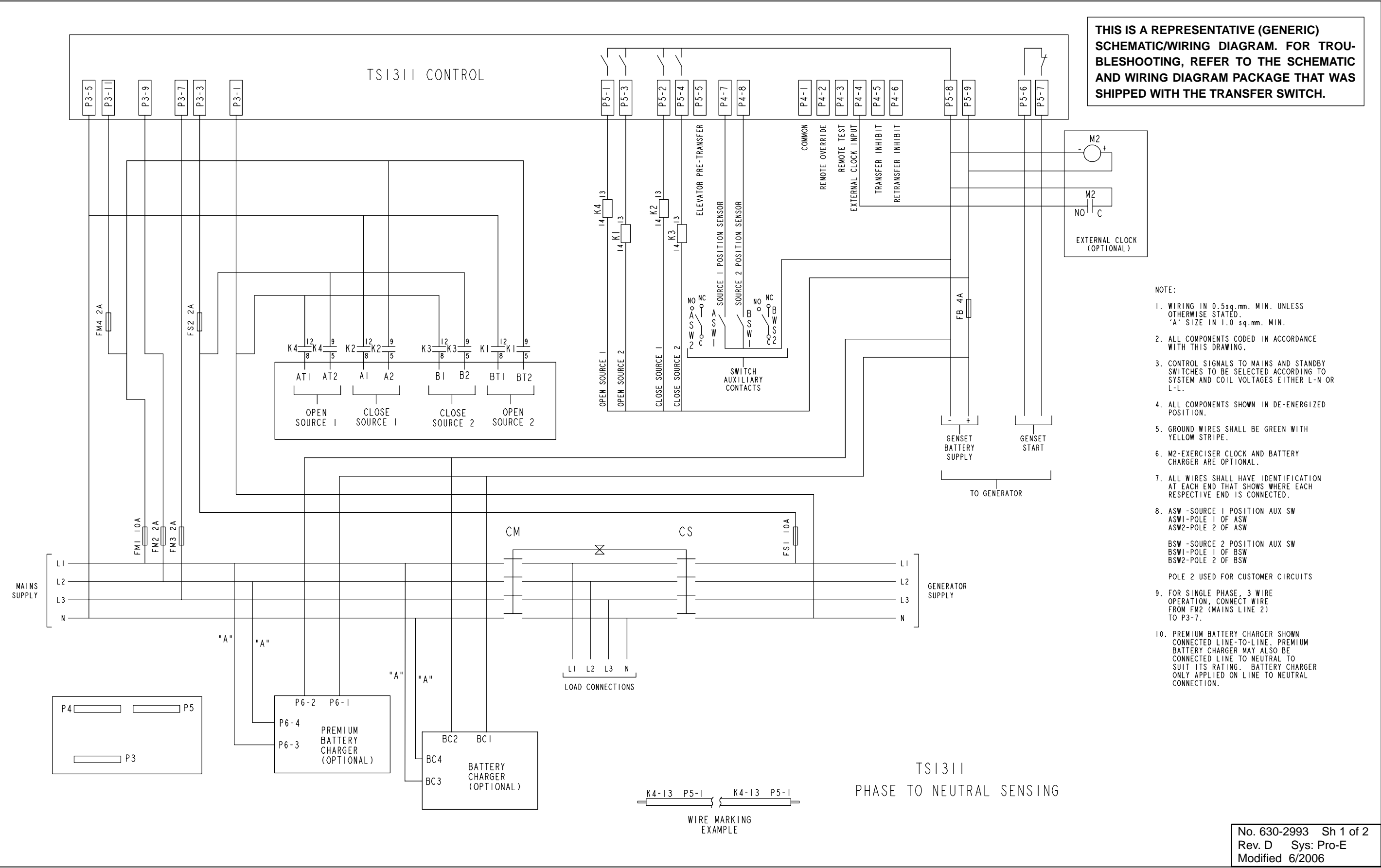
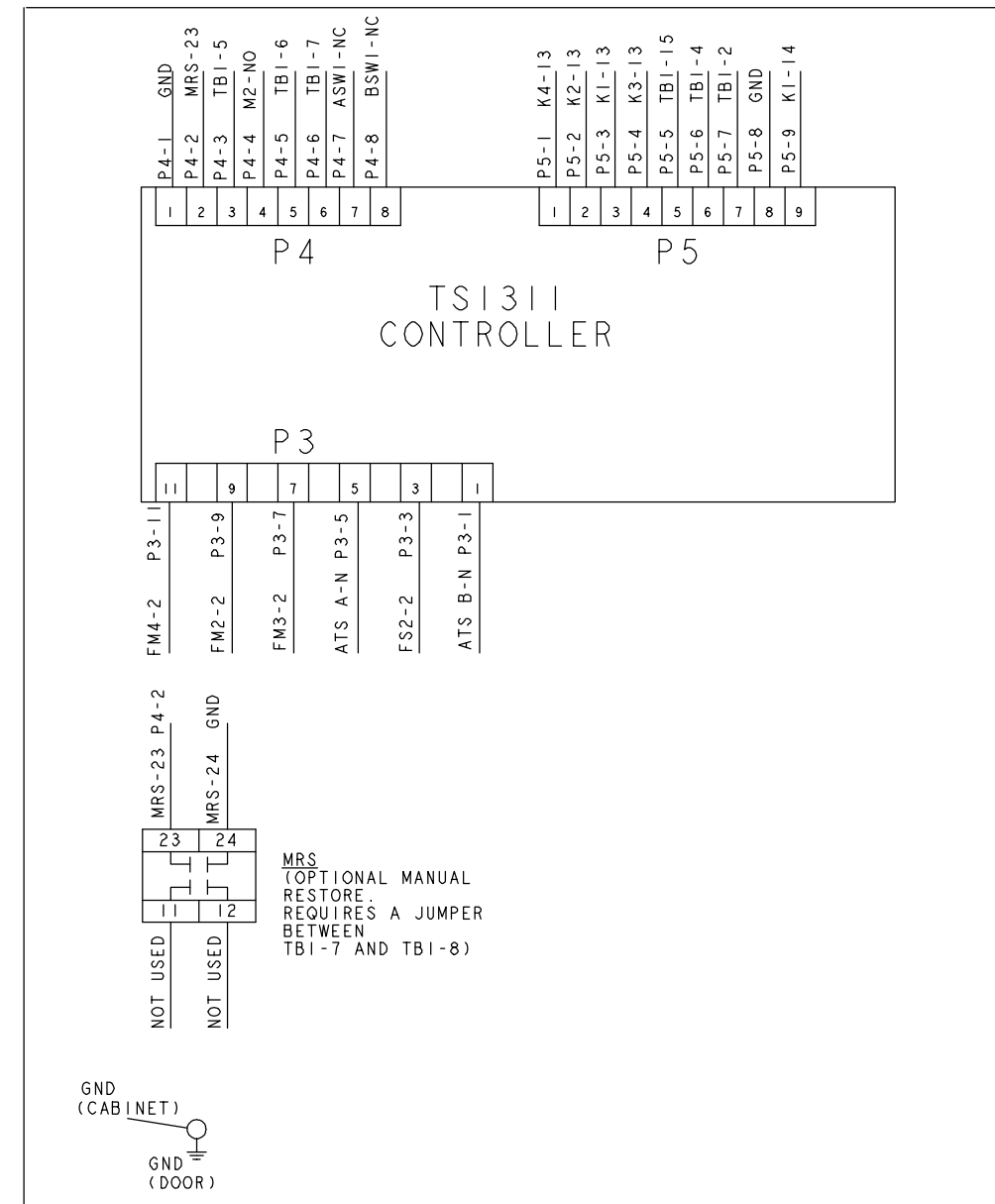
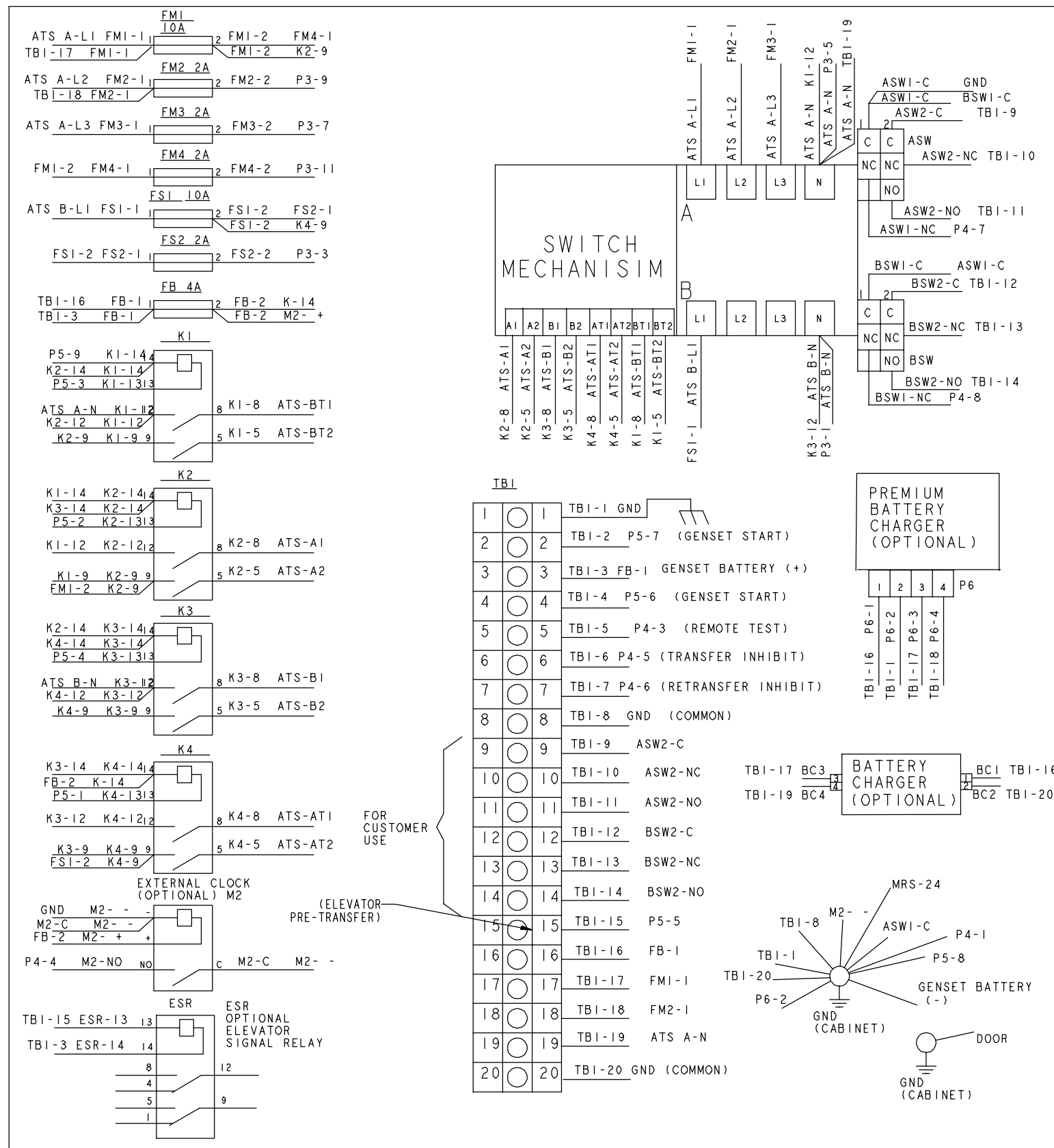

FIGURE 11-8. TRANSFER SWITCH WIRING DIAGRAM (LINE-TO-NEUTRAL SENSING) (SHEET 1 OF 2)

THIS IS A REPRESENTATIVE (GENERIC) SCHEMATIC/WIRING DIAGRAM. FOR TROUBLESHOOTING, REFER TO THE SCHEMATIC AND WIRING DIAGRAM PACKAGE THAT WAS SHIPPED WITH THE TRANSFER SWITCH.



No. 630-2993 Sh 2 of 2
Rev. D Sys: Pro-E
Modified 6/2006

FIGURE 11-8. TRANSFER SWITCH WIRING DIAGRAM (LINE-TO-NEUTRAL SENSING) (SHEET 2 OF 2)

THIS IS A REPRESENTATIVE (GENERIC) SCHEMATIC/WIRING DIAGRAM. FOR TROUBLESHOOTING, REFER TO THE SCHEMATIC AND WIRING DIAGRAM PACKAGE THAT WAS SHIPPED WITH THE TRANSFER SWITCH.

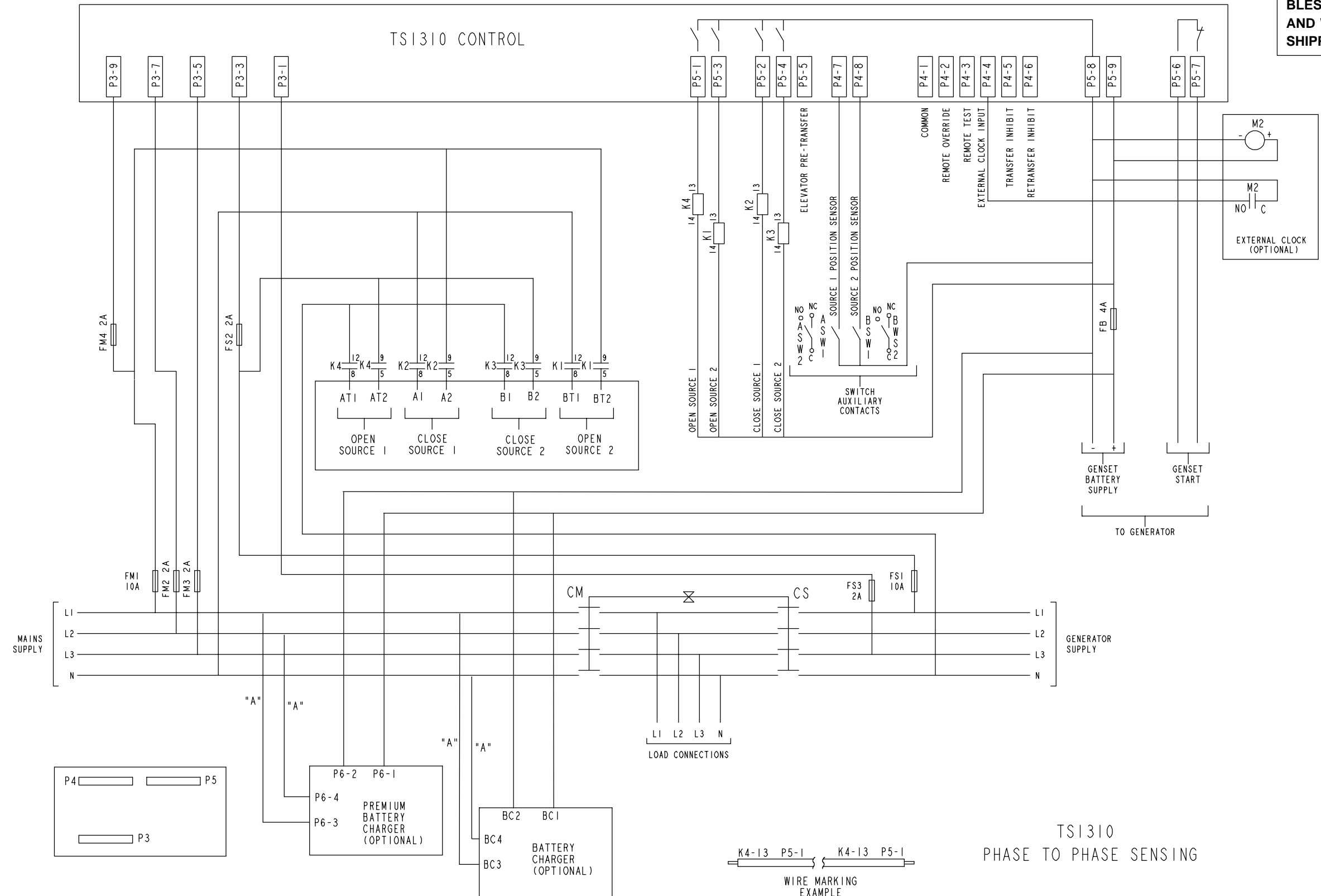

- NOTE:
1. WIRING IN 0.5sq.mm. MIN. UNLESS OTHERWISE STATED. 'A' SIZE IN 1.0 sq.mm. MIN.
 2. ALL COMPONENTS CODED IN ACCORDANCE WITH THIS DRAWING.
 3. CONTROL SIGNALS TO MAINS AND STANDBY SWITCHES TO BE SELECTED ACCORDING TO SYSTEM AND COIL VOLTAGES EITHER L-N OR L-L.
 4. ALL COMPONENTS SHOWN IN DE-ENERGIZED POSITION.
 5. GROUND WIRES SHALL BE GREEN WITH YELLOW STRIPE.
 6. M2-EXERCISER CLOCK AND BATTERY CHARGER ARE OPTIONAL.
 7. ALL WIRES SHALL HAVE IDENTIFICATION AT EACH END THAT SHOWS WHERE EACH RESPECTIVE END IS CONNECTED.
 8. ASW -SOURCE 1 POSITION AUX SW
ASW1-POLE 1 OF ASW
ASW2-POLE 2 OF ASW

BSW -SOURCE 2 POSITION AUX SW
BSW1-POLE 1 OF BSW
BSW2-POLE 2 OF BSW

POLE 2 USED FOR CUSTOMER CIRCUITS
 9. FOR SINGLE PHASE, 3 WIRE OPERATION, CONNECT WIRE FROM FM2 (MAINS LINE 2) TO P3-5. CONNECT NOTHING TO P3-7. CONNECT GENERATOR SIDE OF FS3 TO L2.
 10. PREMIUM BATTERY CHARGER SHOWN CONNECTED LINE TO LINE. PREMIUM BATTERY CHARGER MAY ALSO BE CONNECTED LINE TO NEUTRAL TO SUIT ITS RATING. BATTERY CHARGER ONLY APPLIED ON LINE TO NEUTRAL CONNECTION.

No. 630-2930 Sh 1 of 2
Rev. E Sys: Pro-E
Modified 6/2006

FIGURE 11-9. TRANSFER SWITCH WIRING DIAGRAM (LINE-TO-LINE SENSING) (SHEET 1 OF 2)

THIS IS A REPRESENTATIVE (GENERIC) SCHEMATIC/WIRING DIAGRAM. FOR TROUBLESHOOTING, REFER TO THE SCHEMATIC AND WIRING DIAGRAM PACKAGE THAT WAS SHIPPED WITH THE TRANSFER SWITCH.

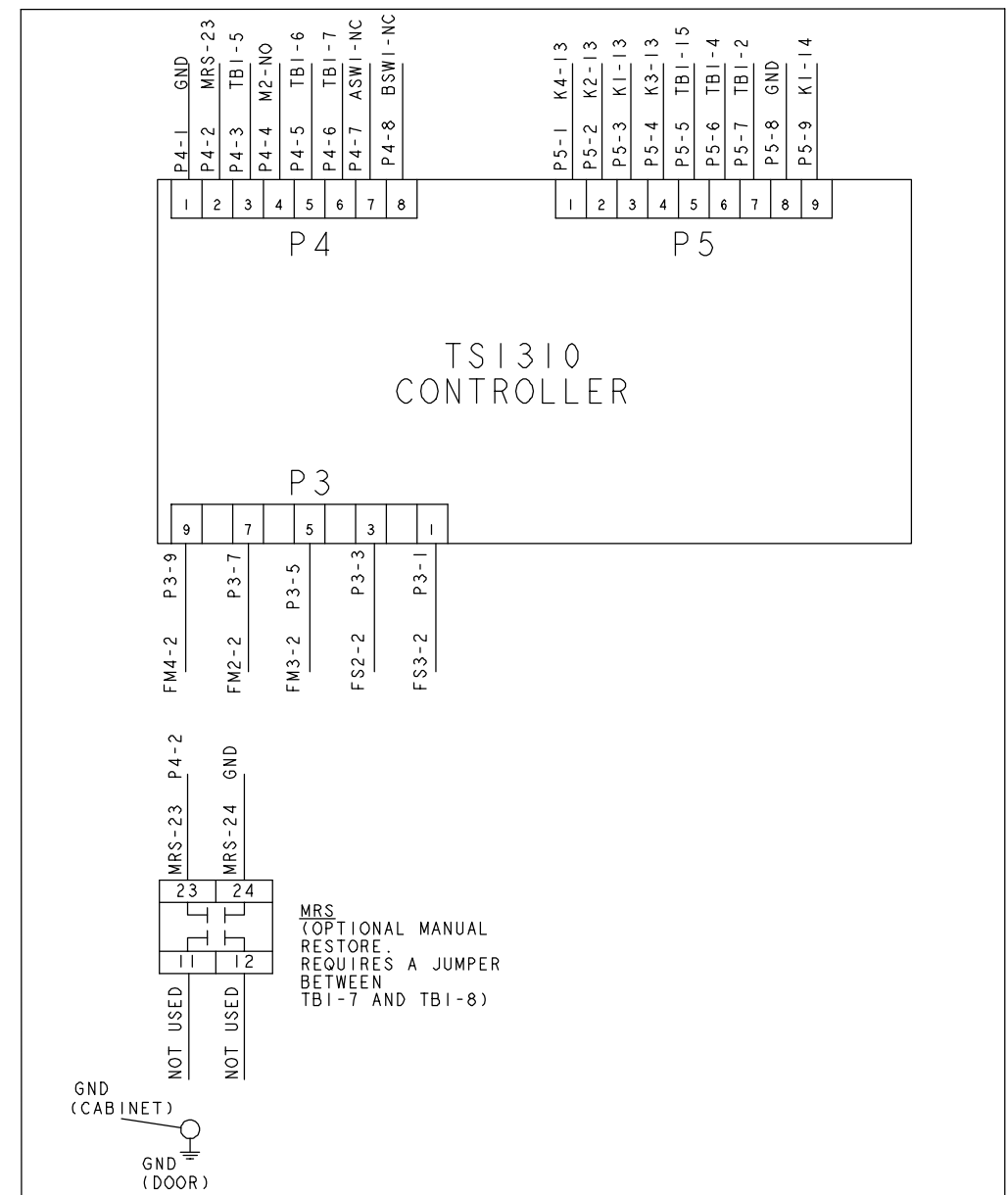
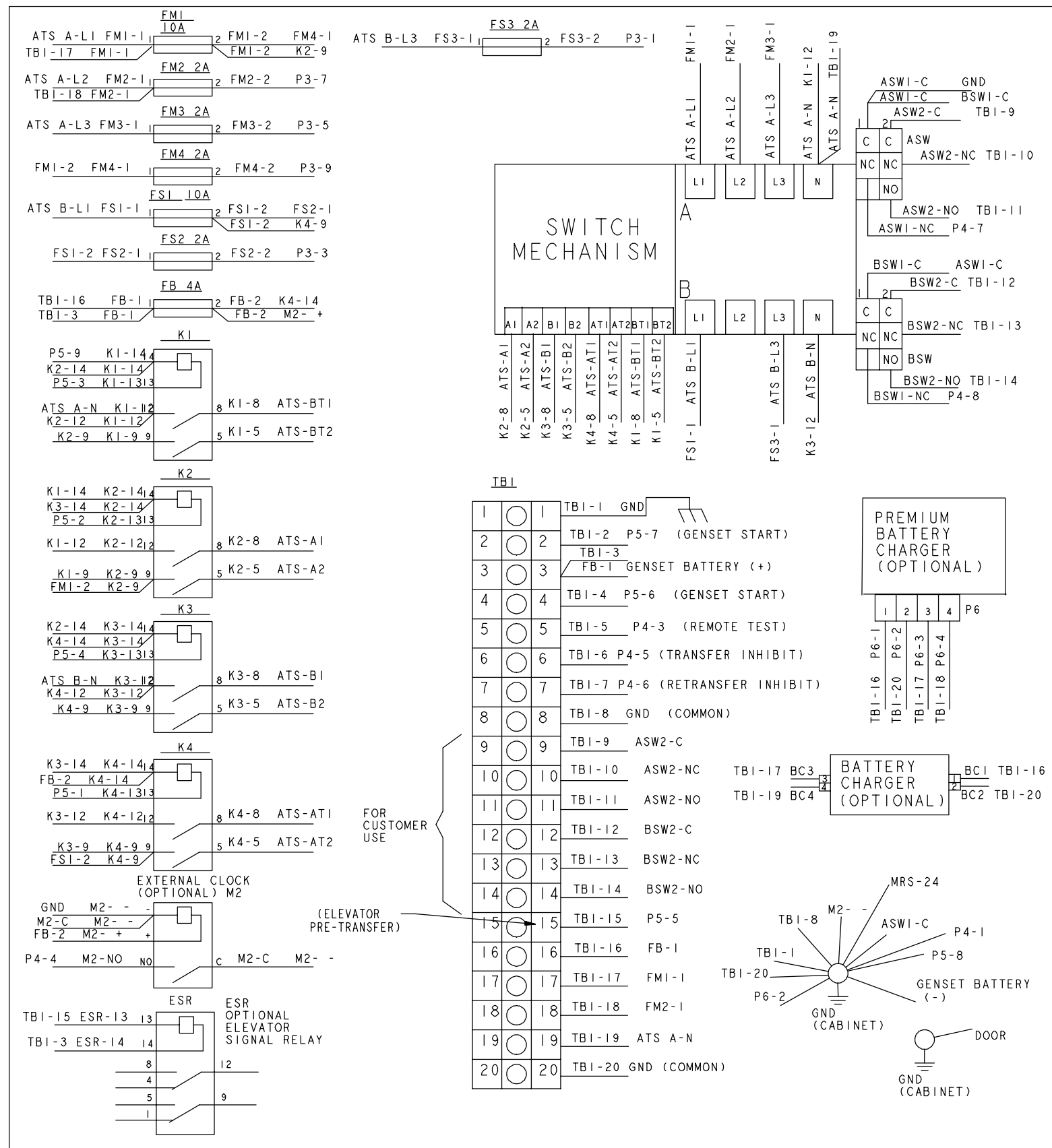

No. 630-2930 Sh 2 of 2
 Rev. E Sys: Pro-E
 Modified 6/2006

FIGURE 11-9. TRANSFER SWITCH WIRING DIAGRAM (LINE-TO-LINE SENSING) (SHEET 2 OF 2)

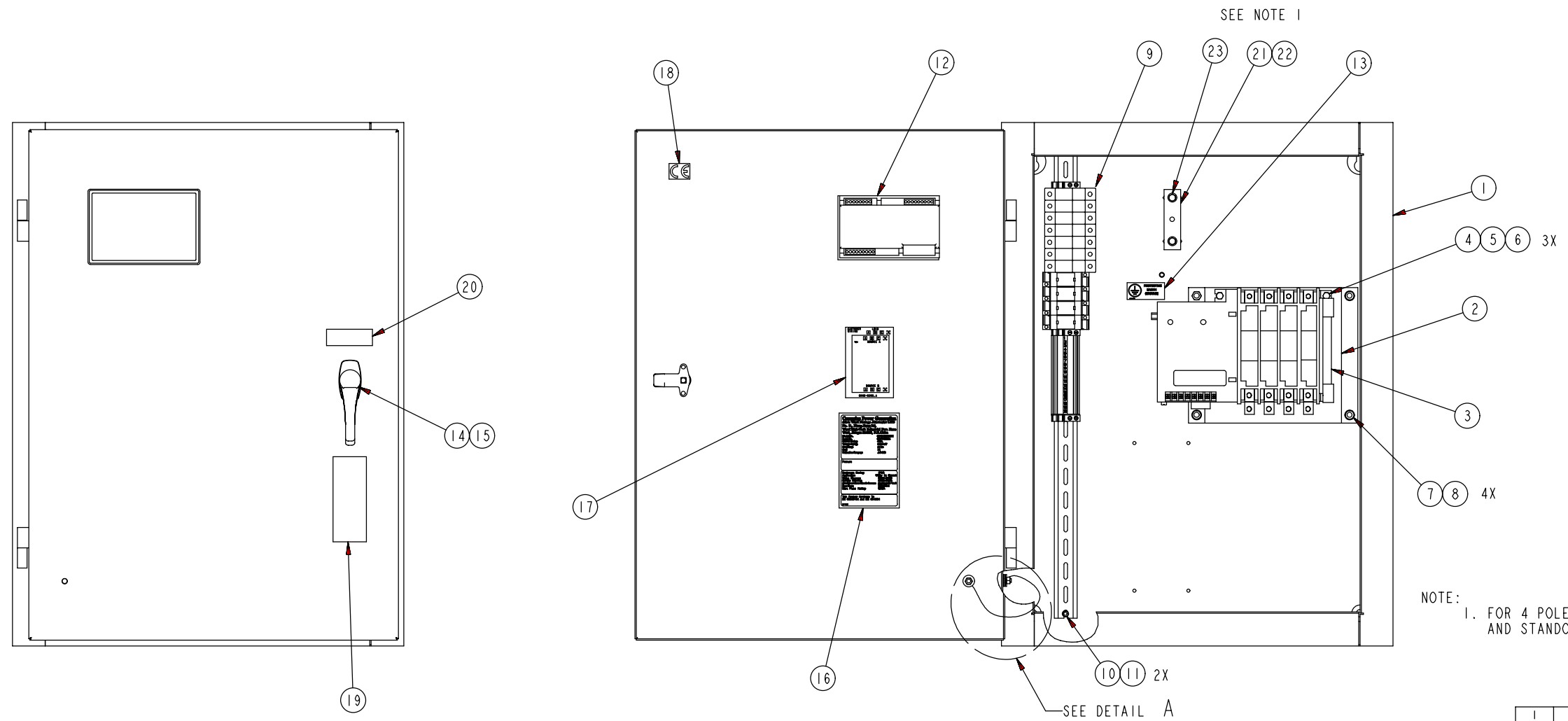

SEE NOTE 1

NOTE:
1. FOR 4 POLE TRANSFER SWITCH, NEUTRAL_BAR AND STANDOFFS (INSULATOR) ARE NOT REQUIRED.

TABULATION	
PART NUMBER	DESCRIPTION
0300_6055_01	12 VDC RELAY INSTL. ASSY
0300_6055_02	24 VDC RELAY INSTL. ASSY

QTY	QTY	ITEM	DESCRIPTION OR MATERIAL
02	01		
1	1	26	LEAD
4	4	25	WASHER-FL (M6)
2	2	24	WASHER-ETIT_LK (1/4)
2	2	23	SCREW_LK_FLANGE
1	1	22	NEUTRAL_BAR
2	2	21	STANDOFF (INSULATOR)
1	1	20	LABEL-INFORMATION
1	1	19	TAG_WARNING
1	1	18	LABEL-EC LISTED
1	1	17	LABEL-INFORMATION
1	1	16	NAMEPLATE-TRANSFER_SW
1	1	15	LATCH-CAM (3_POINT)
1	1	14	HANDLE_LOCKING
1	1	13	LABEL_GROUND
1	1	12	DISPLAY-CONTROL
2	2	11	NUT-HEX (M5X.8)
2	2	10	WASHER-FLAT (M5)
1	-	9	RELAY INSTL (24 VDC)
-	1	9	RELAY INSTL (12 VDC)
4	4	8	NUT-HEX (M8X1.25)
3	3	7	WASHER-SPLIT_LOCK (M8)
5	5	6	NUT-HEX (M6X1)
3	3	5	WASHER-LK_SPLIT (M6)
3	3	4	SCREW-HHC (M6X1 X 20)
1	1	3	TRANSFER SWITCH ASSY
1	1	2	PANEL-SWITCH MTG
1	1	1	CABINET ASSY

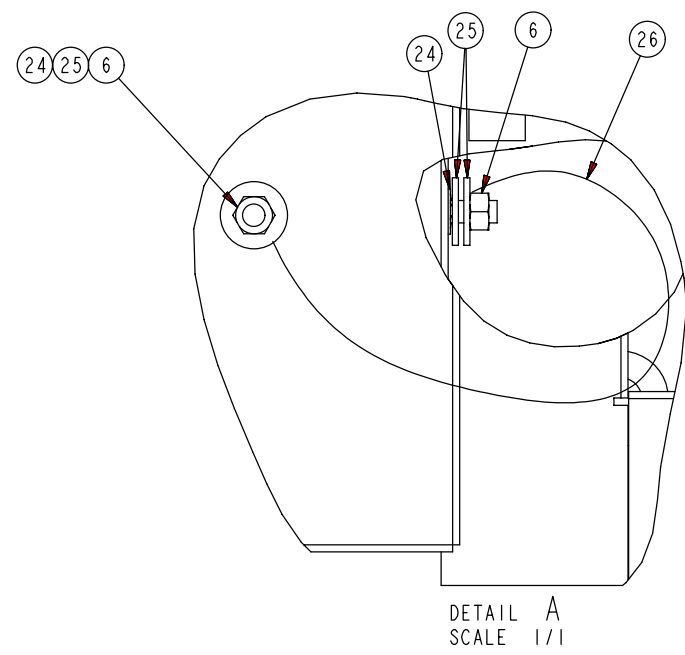

DETAIL A
SCALE 1/1

No. 300-6055 Sh 1 of 1
Rev. A Sys: Pro-E
Modified 6/2005

FIGURE 11-10. TRANSFER SWITCH SMALL CABINET ASSEMBLY

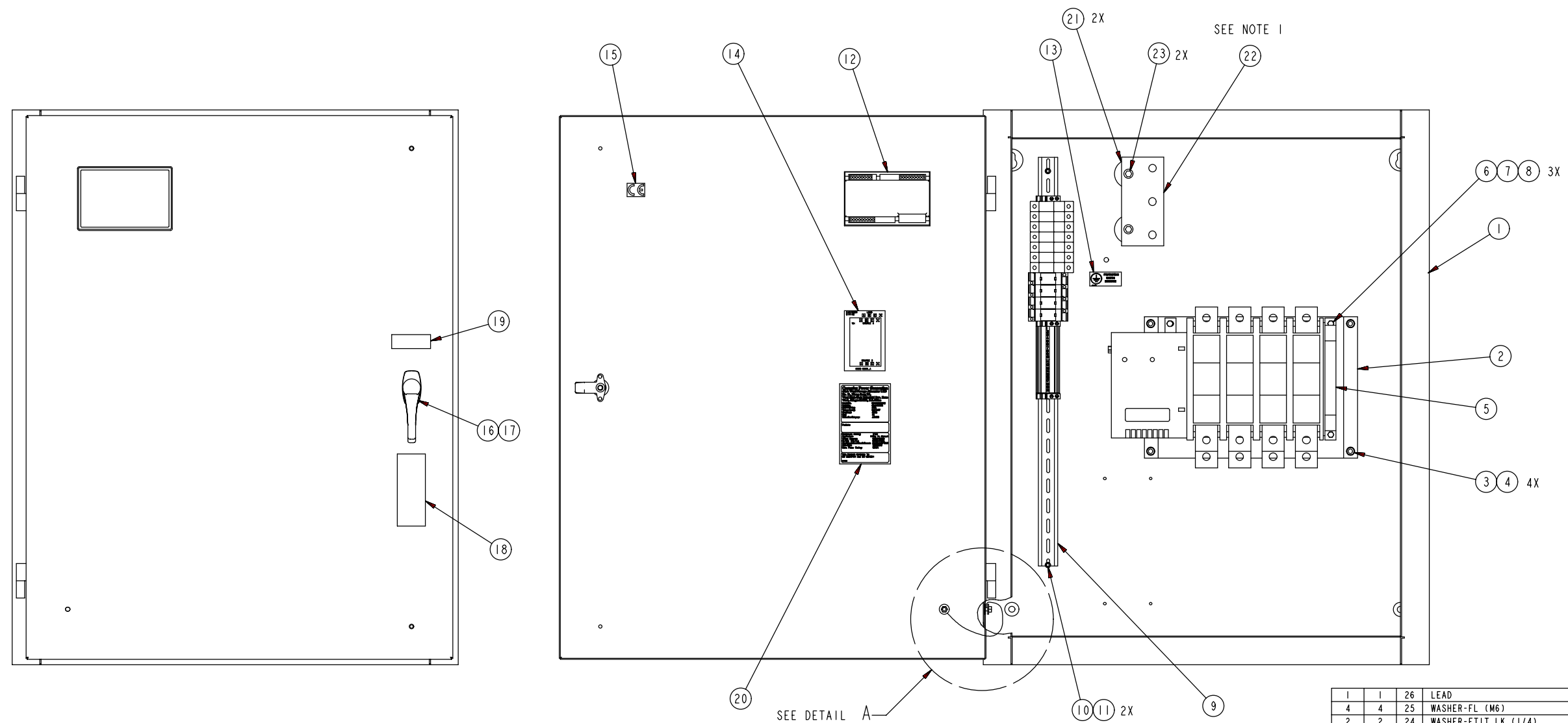

TABULATION	
PART NUMBER	DESCRIPTION
0300_6056_01	12 VDC RELAY INSTL. ASSY
0300_6056_02	24 VDC RELAY INSTL. ASSY

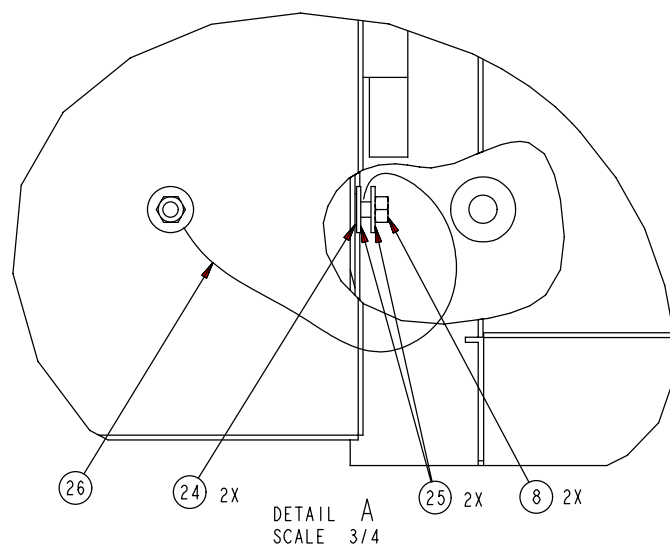

NOTE:
1. FOR 4 POLE TRANSFER SWITCH, NEUTRAL_BAR AND
AND STANDOFFS (INSULATOR) ARE NOT REQUIRED.

QTY	QTY	ITEM	DESCRIPTION OR MATERIAL
-02	-01		
1	1	26	LEAD
4	4	25	WASHER-FL (M6)
2	2	24	WASHER-ETIT_LK (1/4)
2	2	23	SCREW-HH_FLG (M8X1.25-X-18)
1	1	22	BUS_BAR
2	2	21	STANDOFF (INSULATOR)
1	1	20	NAMEPLATE-TRANSFER_SW
1	1	19	LABEL-INFORMATION
1	1	18	TAG_WARNING
1	1	17	LATCH-CAM (3_POINT)
1	1	16	HANDLE_LOCKING
1	1	15	LABEL-EC LISTED
1	1	14	LABEL-INFORMATION
1	1	13	LABEL_GROUND
1	1	12	DISPLAY-CONTROL
2	2	11	NUT-HEX (M5X.8)
2	2	10	WASHER-FLAT (M5)
1	-	9	RELAY INSTL. (24 VDC)
-	1	9	RELAY INSTL. (12 VDC)
5	5	8	NUT-HEX (M6X1)
3	3	7	WASHER-LK_SPLIT (M6)
3	3	6	SCREW-HHC (M6X1 X 20)
1	1	5	TRANSFER_SWITCH_ASSY
4	4	4	NUT-HEX (M8X1.25)
4	4	3	WASHER-SPLIT_LOCK (M8)
1	1	2	PANEL-SWITCH_MTG
1	1	1	CABINET_ASSY

No. 300-6056 Sh 1 of 1
Rev. A Sys: Pro-E
Modified 5/2005

FIGURE 11-11. TRANSFER SWITCH MEDIUM CABINET ASSEMBLY

TABULATION	
PART NUMBER	DESCRIPTION
0300_6057_01	12 VDC RELAY INSTL. ASSY
0300_6057_02	24 VDC RELAY INSTL. ASSY

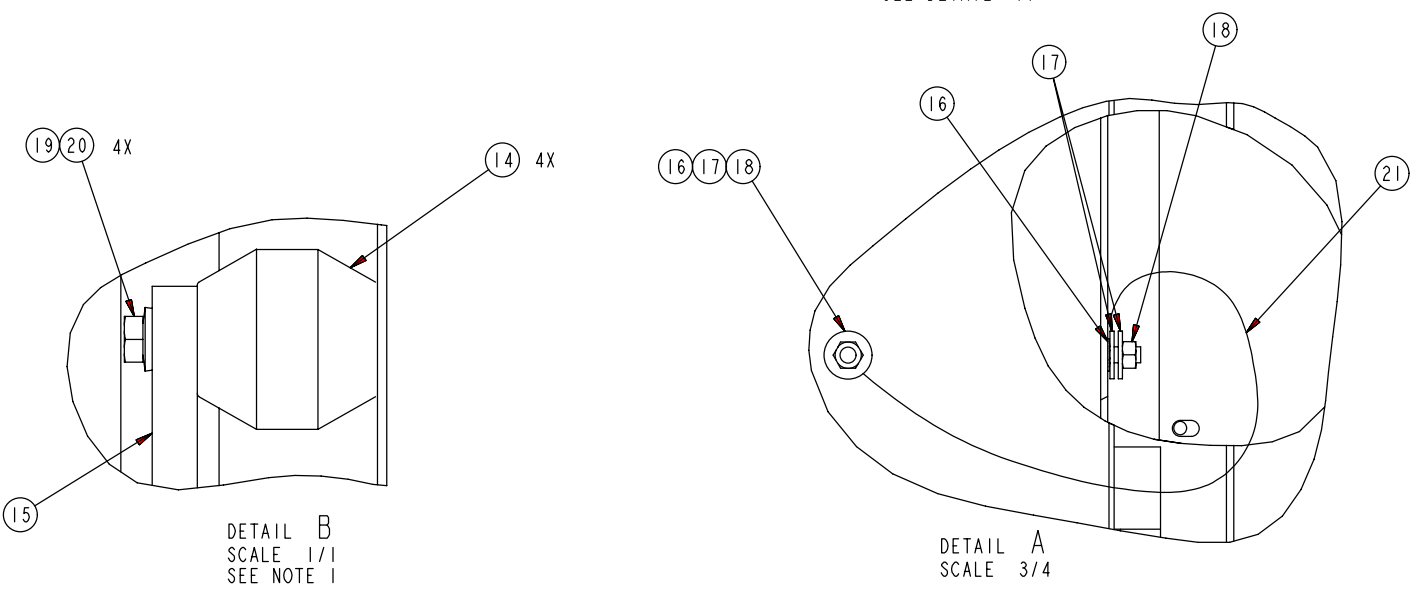
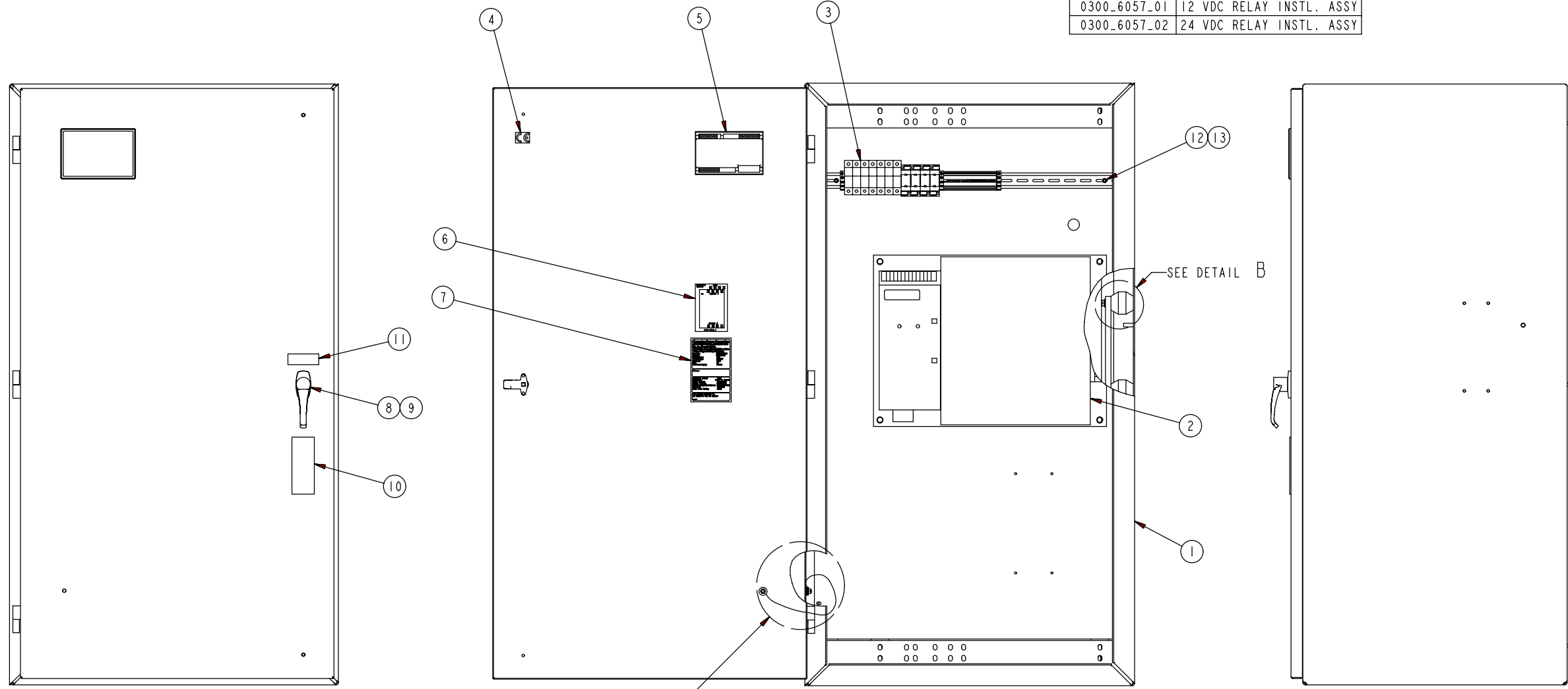

NOTE:
1. FOR 4 POLE TRANSFER SWITCH, NEUTRAL_BAR AND AND STANDOFFS (INSULATOR) ARE NOT REQUIRED.

1	1	21	LEAD
4	4	20	SCREW-HHC (M8X1.25 X 30)
4	4	19	WASHER-SPRING (5/16)
2	2	18	NUT-HEX (M6X1)
4	4	17	WASHER-FL (M6)
2	2	16	WASHER-ETIT-LK (1/4)
1	1	15	BUS_BAR
4	4	14	STANDOFF
2	2	13	NUT-HEX (M5X.8)
2	2	12	WASHER-FLAT (M5)
1	1	11	LABEL-INFORMATION
1	1	10	TAG_WARNING
1	1	9	LATCH-CAM (3_POINT)
1	1	8	HANDLE_LOCKING
1	1	7	NAMEPLATE-TRANSFER_SW
1	1	6	LABEL-INFORMATION
1	1	5	DISPLAY-CONTROL
1	1	4	LABEL-EC LISTED
1	-	3	RELAY INSTL (24 VDC)
-	1	3	RELAY INSTL (12 VDC)
1	1	2	TRANSFER_SWITCH_ASSY
1	1	1	CABINET ASSY
QTY -02	QTY -01	ITEM	DESCRIPTION OR MATERIAL

No. 300-6057 Sh 1 of 1
Rev. A Sys: Pro-E
Modified 6/2005

FIGURE 11-12. TRANSFER SWITCH LARGE CABINET ASSEMBLY

Cummins Power Generation
1400 73rd Avenue N.E.
Minneapolis, MN 55432
1-800-888-6626
763-574-5000 International Use
Fax: 763-528-7229

Cummins is a registered trademark of Cummins Inc.

