

Curso Técnico em Eletrotécnica

Lei de Faraday e Lenz

Auto-indutância e Indutores

Capítulo 12: Indutores

1. Lei de Faraday;
2. Lei de Lenz;
3. Auto-indutância;
4. Tipos de indutores.

Vitória-ES

Indução eletromagnética

Experiência de Faraday:

- No momento que a chave é fechada, o galvanômetro acusa uma pequena corrente de curta duração;
- Após a corrente cessar e durante tempo em que a chave permanecer fechada, o galvanômetro não mais acusa corrente;
- Ao abrir-se a chave, o galvanômetro volta a indicar uma corrente de curta duração, em sentido oposto ao observado no momento de fechamento da chave.

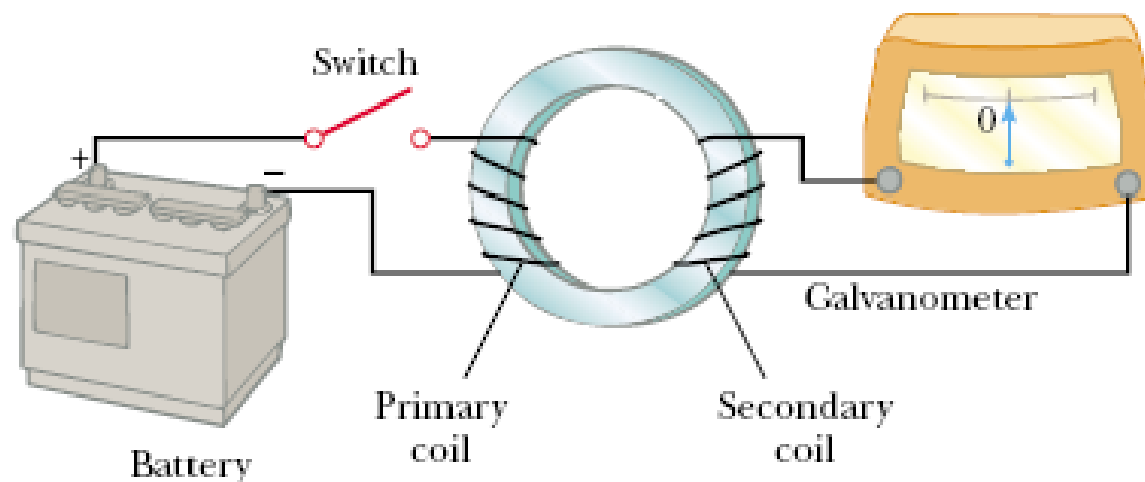

Indução eletromagnética

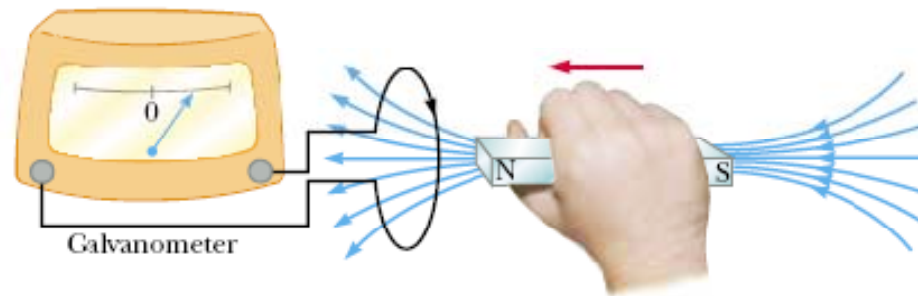

(a)

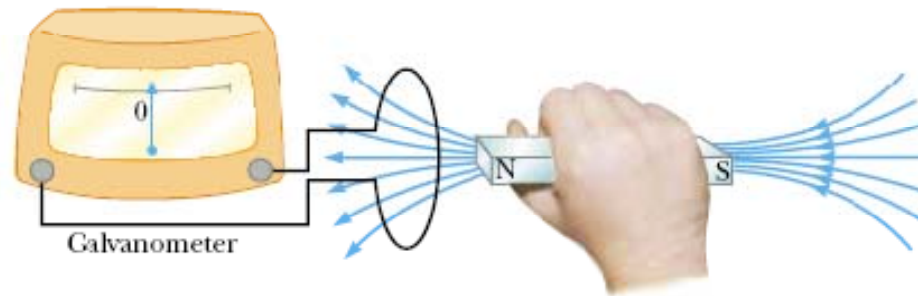

(b)

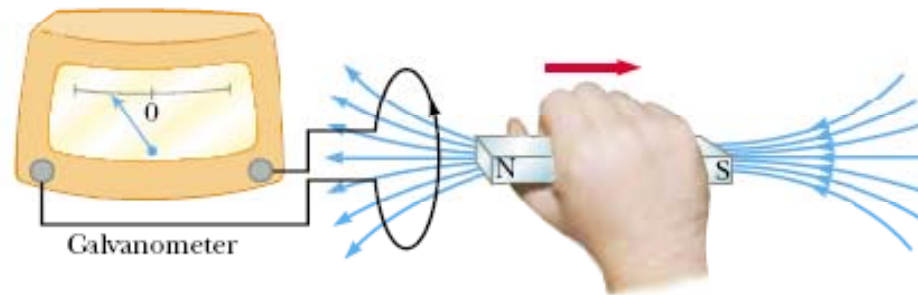

(c)

Indução eletromagnética

A indução eletromagnética é regida por duas leis:

- Lei de Faraday;
- Lei de Lenz.

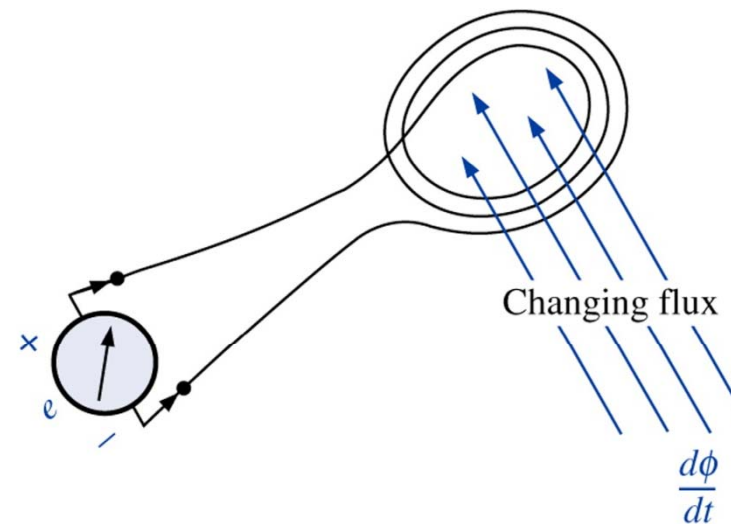
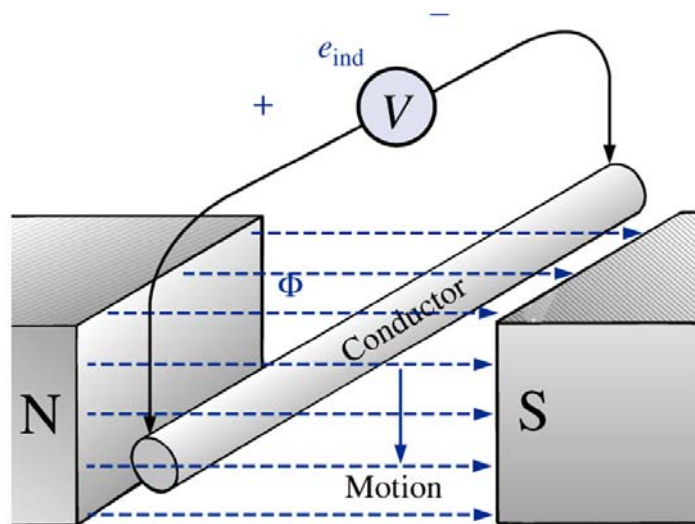

Indução eletromagnética

Lei da indução eletromagnética de Faraday:

Em todo condutor enquanto sujeito a uma variação de fluxo magnético é estabelecida uma força eletromotriz (tensão) induzida.

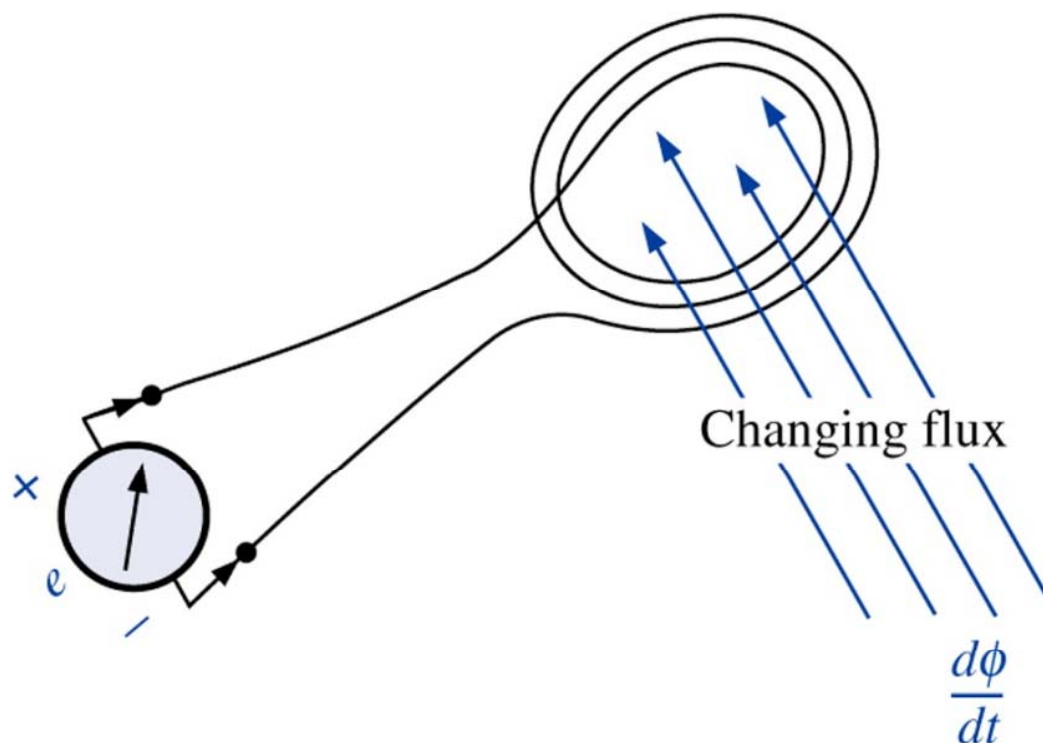

$$\varepsilon = N \frac{d\phi}{dt} \quad [\text{volts, V}]$$

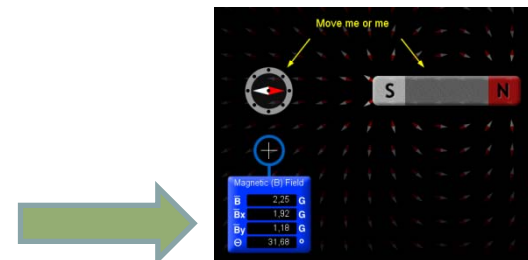

Tensão induzida em condutores num campo

$$\mathcal{E} = -N \frac{d\phi}{dt}$$

$$\phi = B \cdot A \cdot \text{sen}(\theta)$$

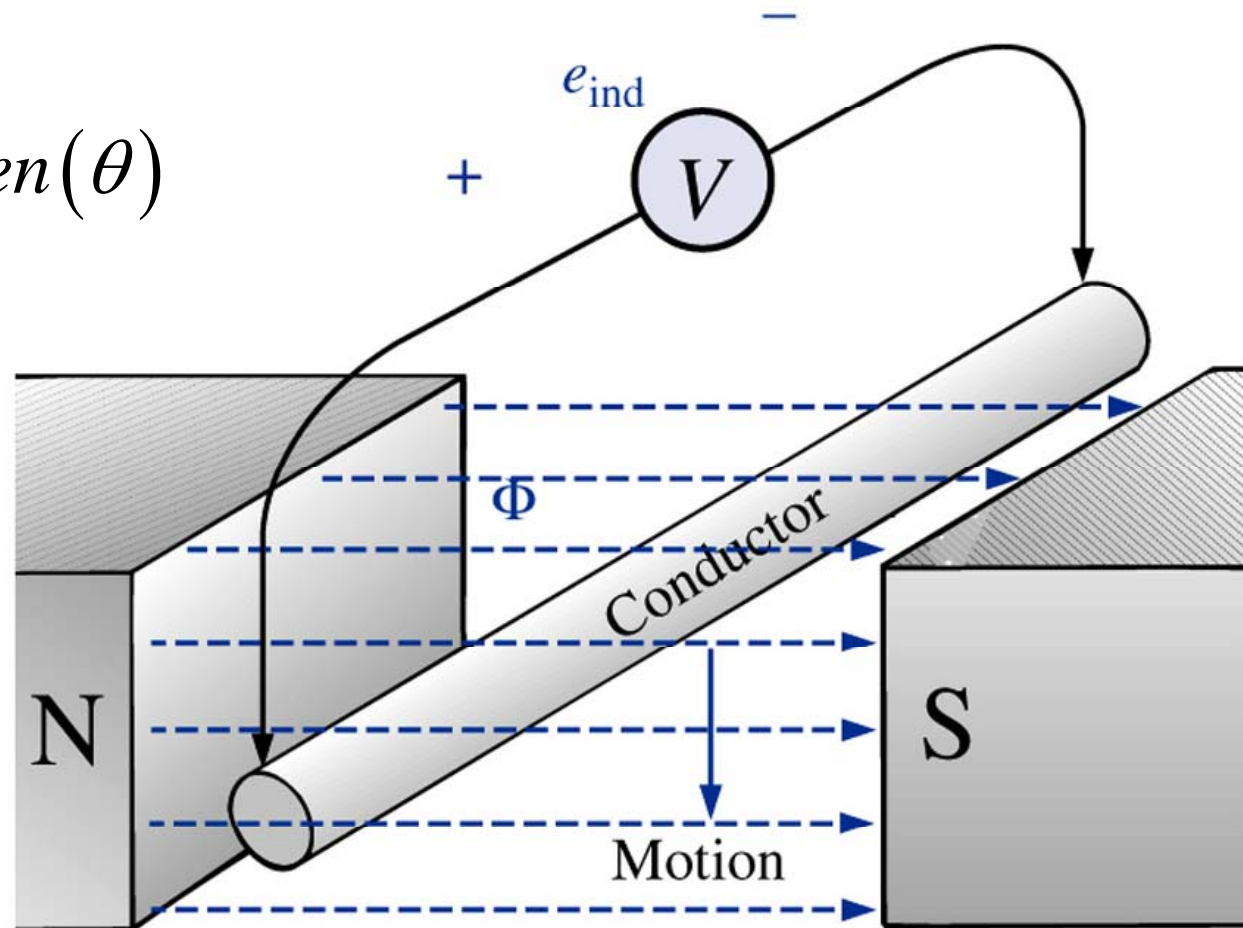

Lei de Lenz

Lei de Lenz:

O sentido da corrente induzida é tal que origina um fluxo magnético induzido, que se opõe à variação do fluxo magnético indutor.

$$\varepsilon = -N \frac{d\phi}{dt}$$

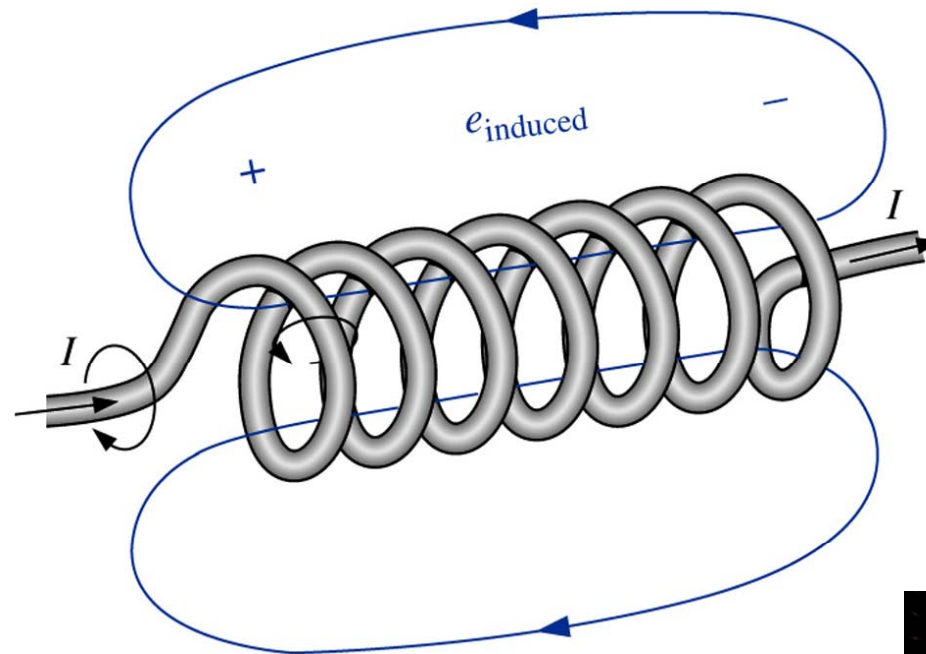

Um efeito induzido ocorre sempre de forma a se opor à causa que o produziu.

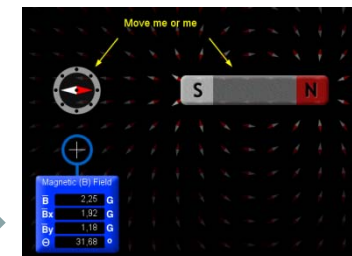

Indução eletromagnética

Com base nas leis da indução, explicar o comportamento do amperímetro na figura abaixo:

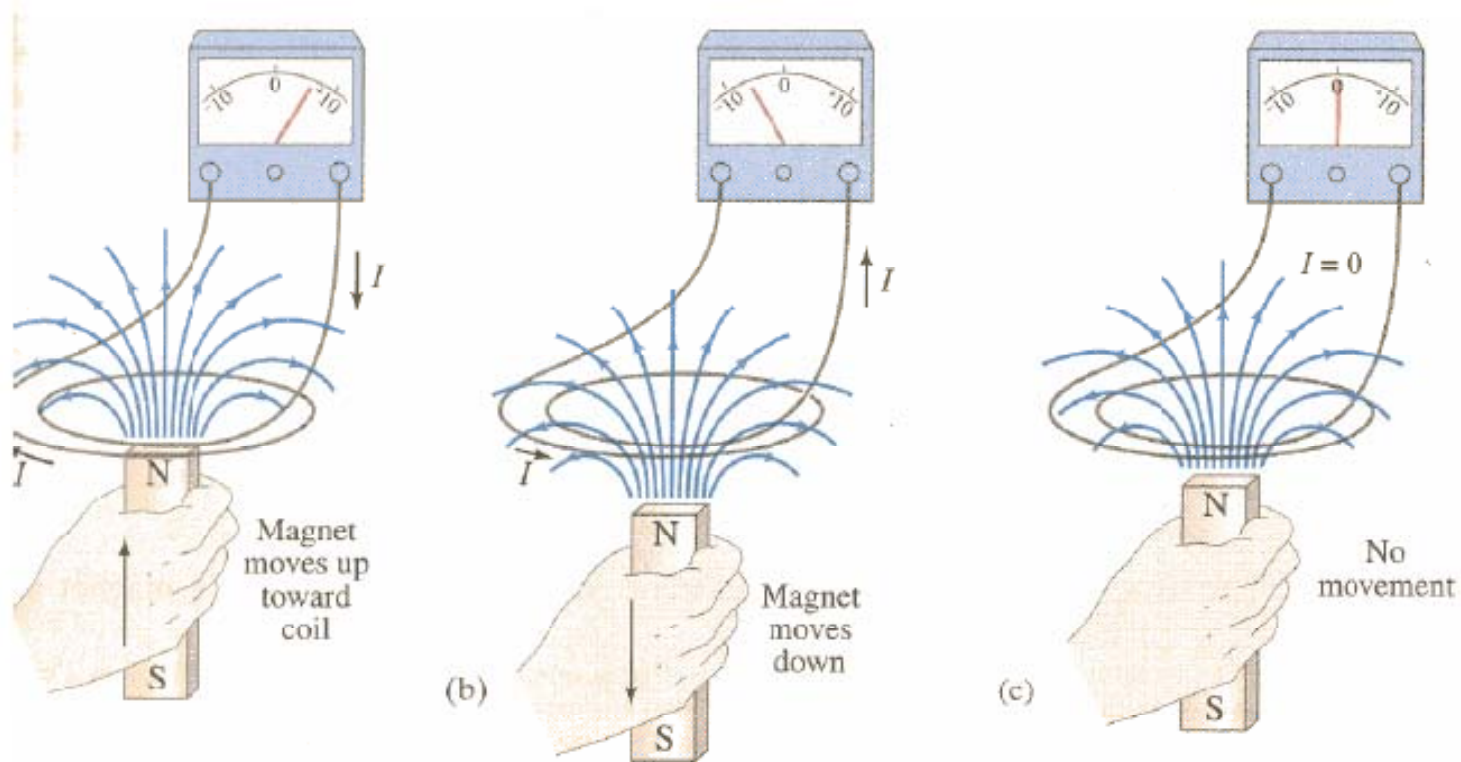

Aplicações – Disjuntor diferencial

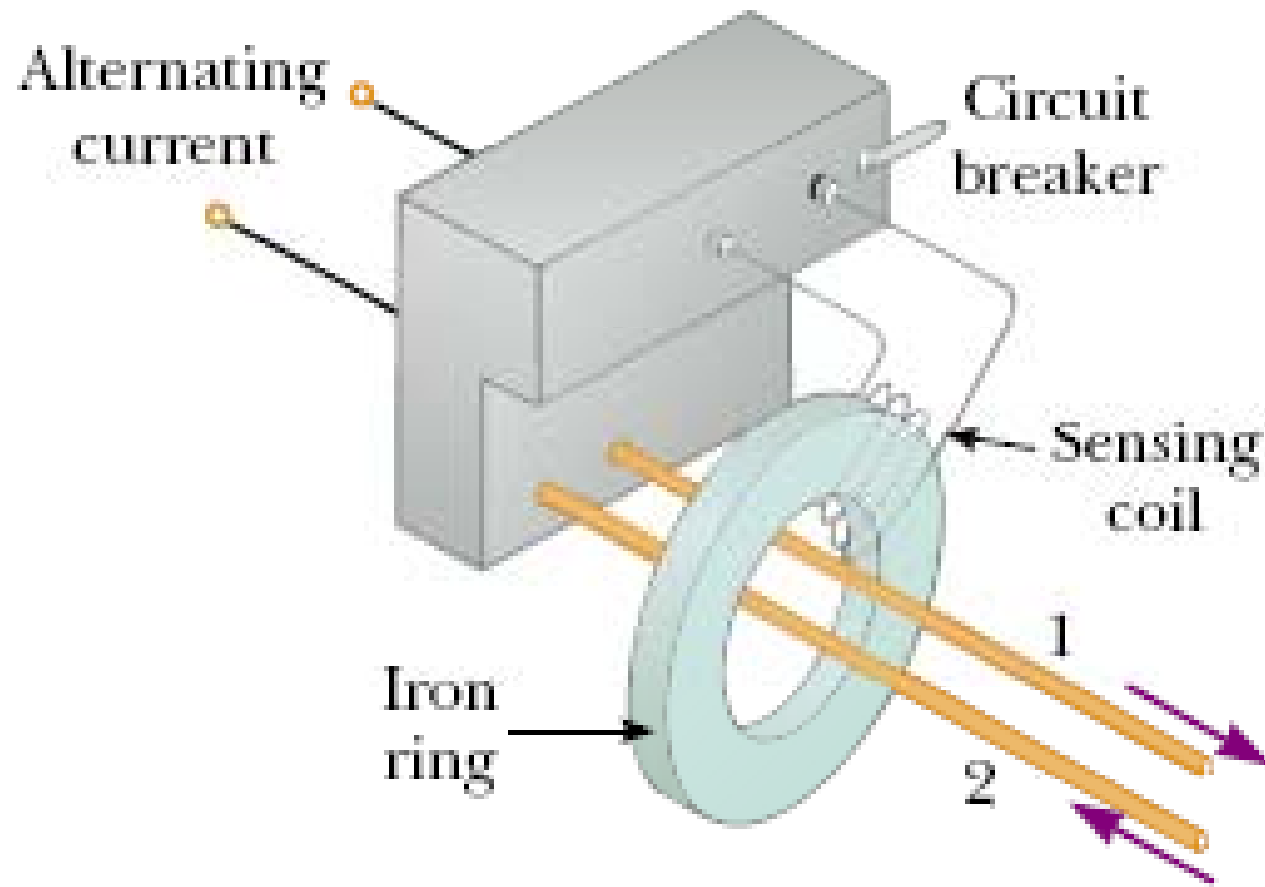

Aplicações – Forno ou panela de indução



Aplicações – Guitarra elétrica

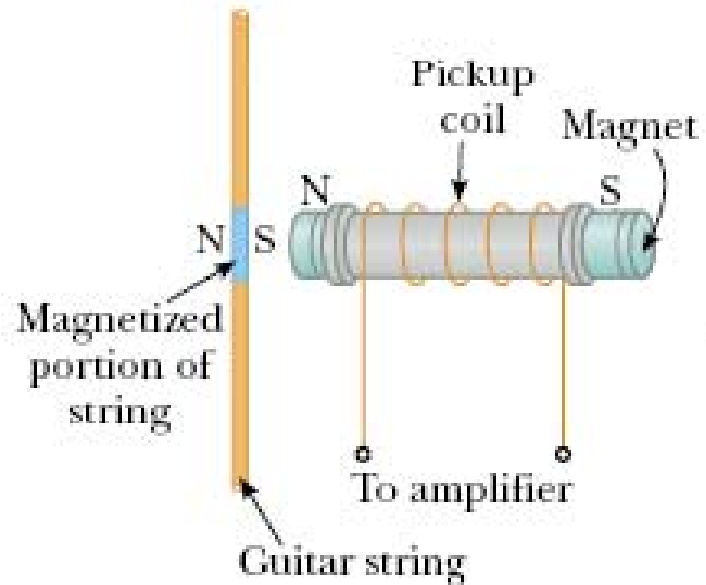

Aplicações – Geração de CA

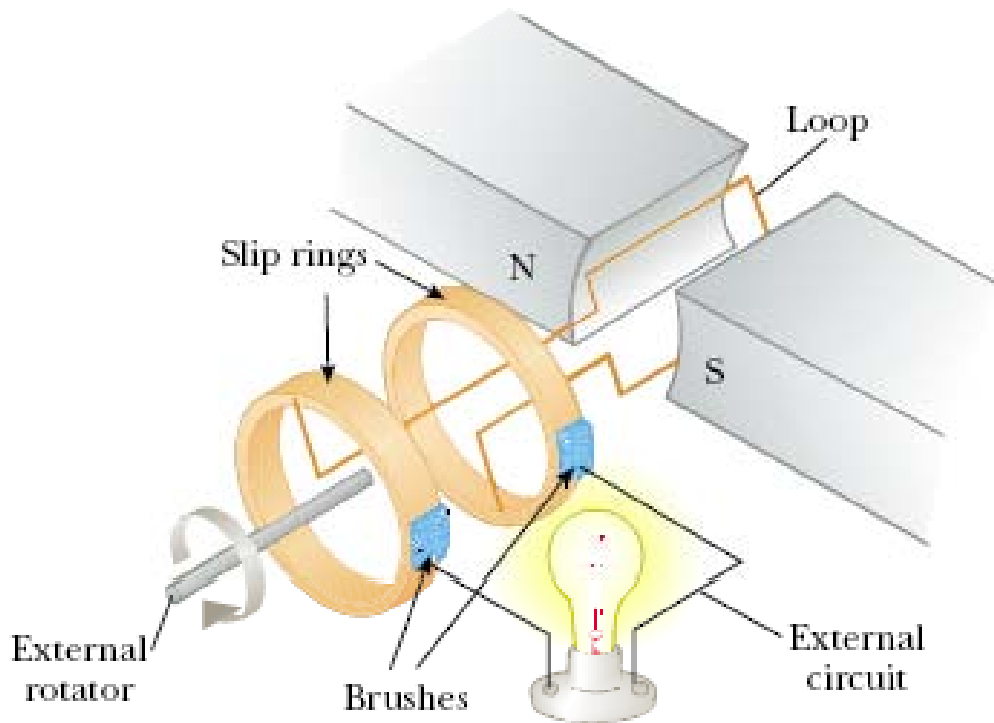

Applets em java →

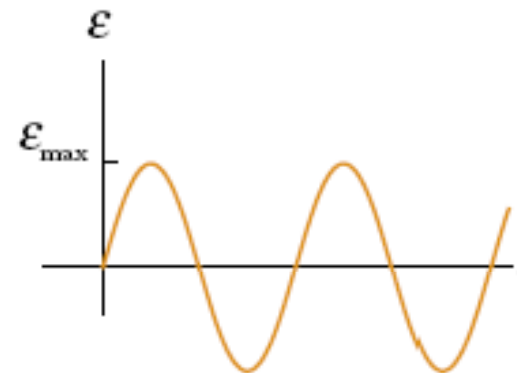
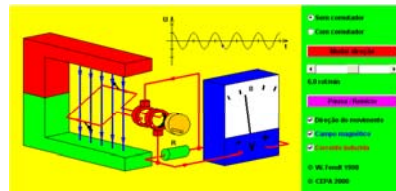

Aplicações – Gerador CC

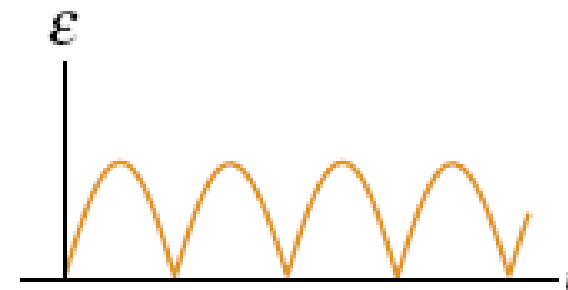
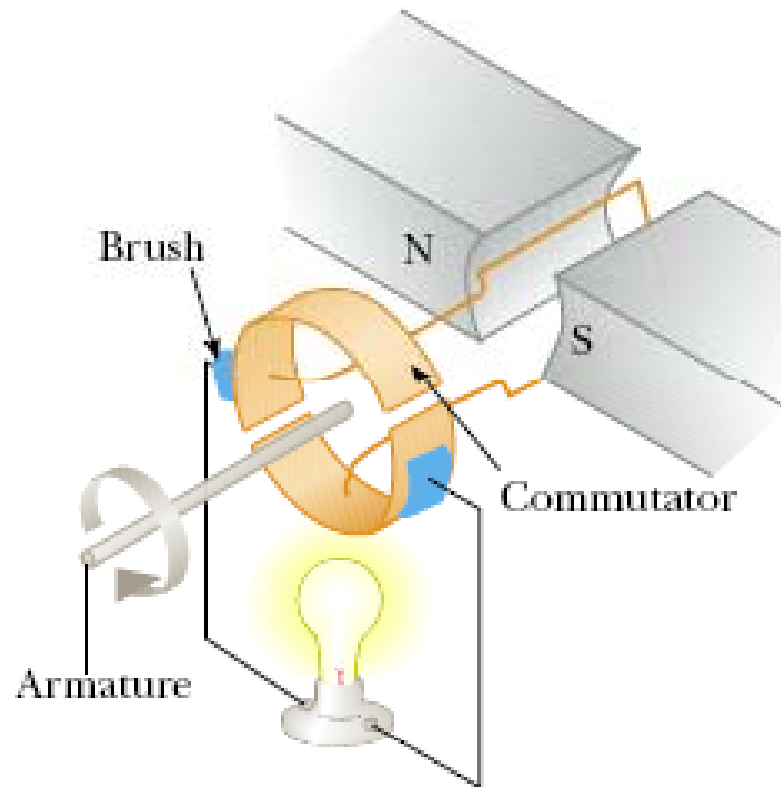

Applets em java →

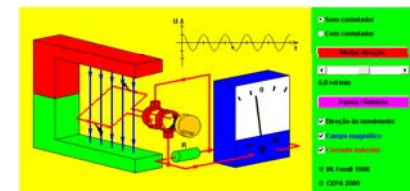

Auto-Indutância

A propriedade de uma bobina de se opor a qualquer variação de corrente é medida pela sua auto-indutância (L). A unidade de medida é o Henry (H).

$$L = \frac{N^2 \cdot \mu \cdot A}{l}$$

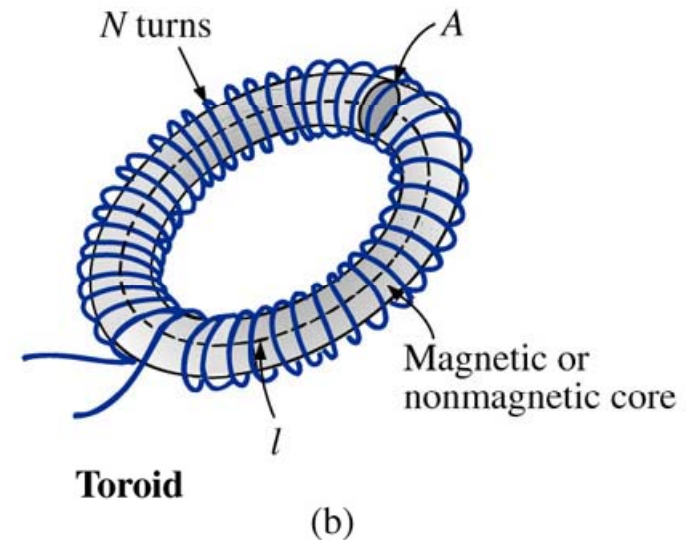
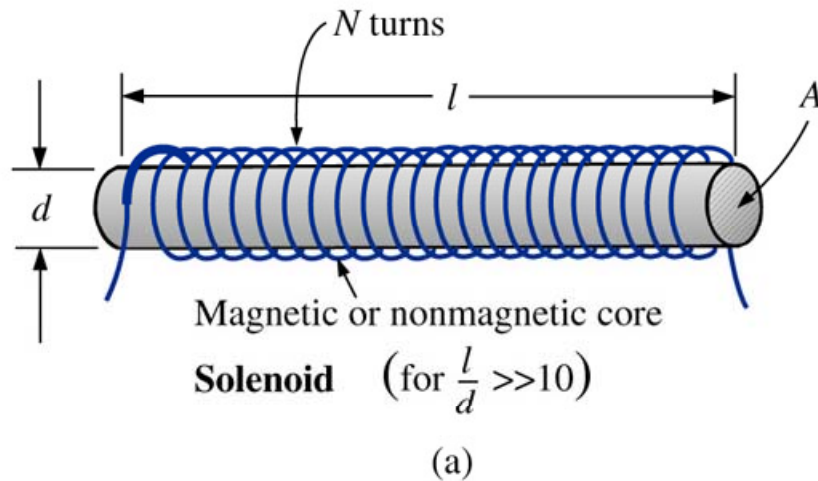

Auto-Indutância

Exemplo 12.1: Determine a indutância da bobina de núcleo de ar da figura abaixo:

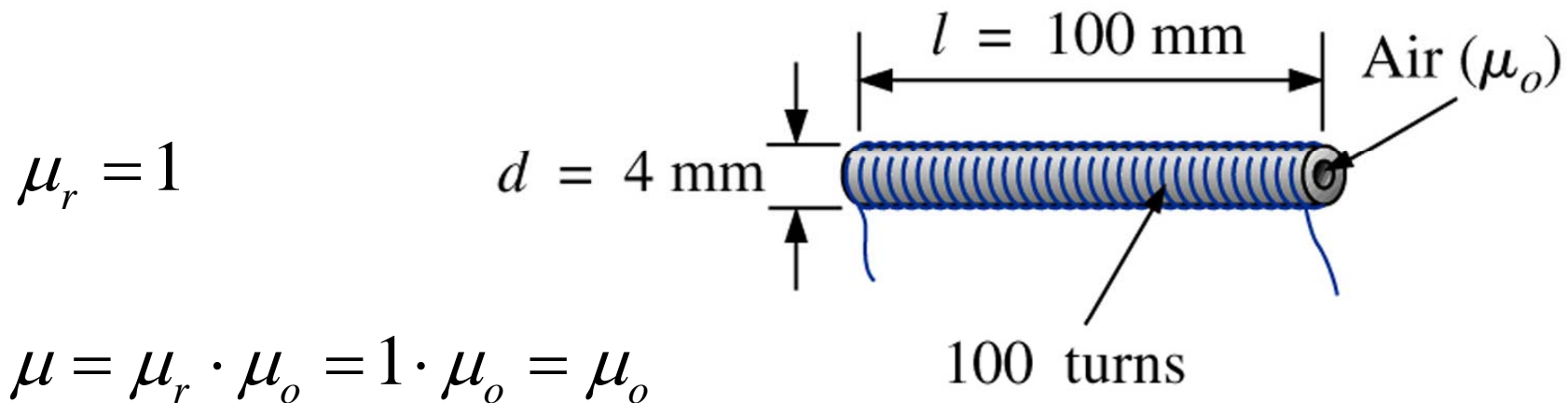

$$\mu_r = 1$$

$$\mu = \mu_r \cdot \mu_o = 1 \cdot \mu_o = \mu_o$$

$$A = \frac{\pi \cdot d^2}{4} = \frac{\pi \cdot (4 \cdot 10^{-3})^2}{4}$$

$$L = \frac{N^2 \cdot \mu \cdot A}{l}$$

$$A = 12,57 \cdot 10^{-6} \text{ m}^2 \quad L = \frac{100^2 \cdot 4\pi \cdot 10^{-7} \cdot 12,57 \cdot 10^{-6}}{0,1} = 1,58 \mu\text{H}$$

Circuito equivalente de um indutor

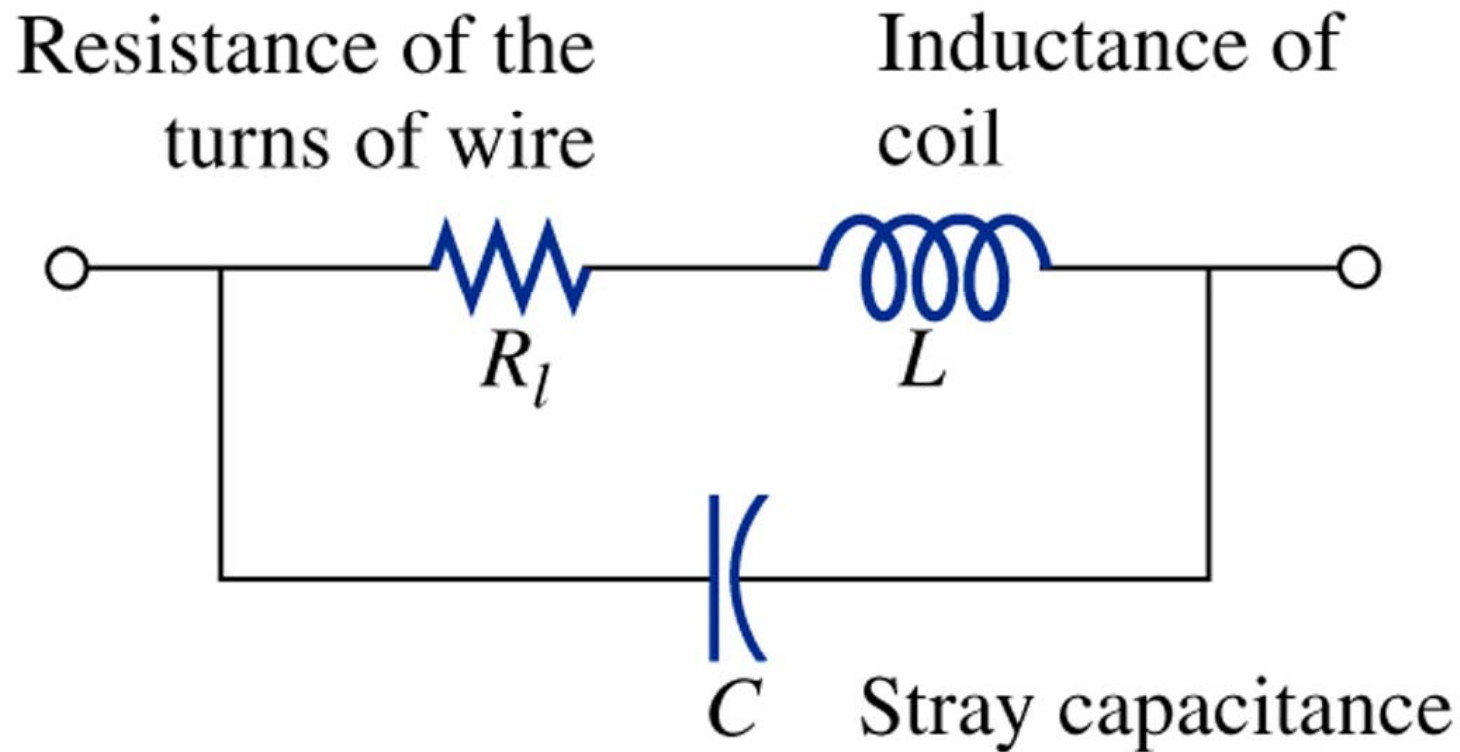

Circuito equivalente completo de um indutor

Circuito equivalente de um indutor

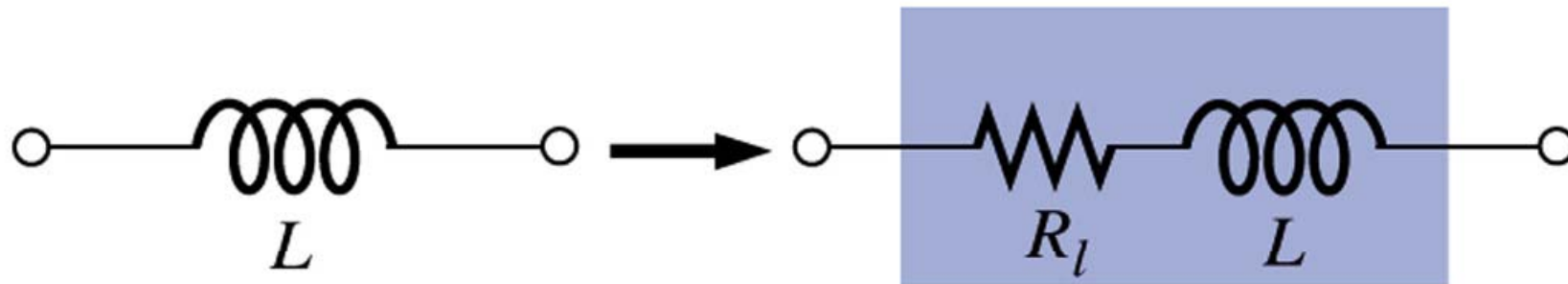

Circuito equivalente prático de um indutor

Símbolos de indutores



Air-core



Iron-core



Variable
(permeability-tuned)

Indutores na prática



(a)

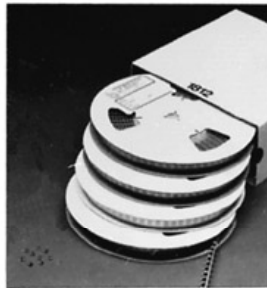

(b)



(c)



(d)



(e)



(f)

Indutores na prática

Type: Open Core Coil
Typical Values: 3 mH to 40 mH
Applications: Used in low-pass filter circuits. Found in speaker crossover networks.



Type: Toroid Coil
Typical Values: 1 mH to 30 mH
Applications: Used as a choke in AC power lines circuits to filter transient and reduce EMI interference. This coil is found in many electronic appliances.

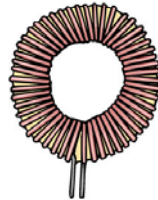

Type: Hash Choke Coil
Typical Values: 3 μ H to 1 mH
Applications: Used in AC supply lines that deliver high currents.

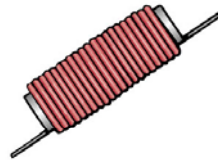

Type: Delay Line Coil
Typical Values: 10 μ H to 50 μ H
Applications: Used in color televisions to correct for timing differences between the color signal and black and white signal.

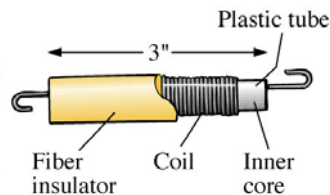

Type: Common Mode Choke Coil
Typical Values: 0.6 mH to 50 mH
Applications: Used in AC line filters, switching power supplies, battery charges and other electronic equipment.

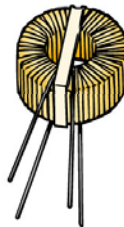

Type: RF Chokes
Typical Values: 10 μ H to 50 μ H
Applications: Used in radio, television, and communication circuits. Found in AM, FM, and UHF circuits.

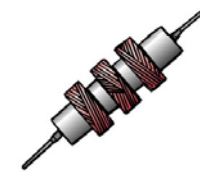

Type: Moiled Coils
Typical Values: 0.1 μ H to 100 μ H
Applications: Used in a wide variety of circuit such as oscillators, filters, pass-band filters, and others.



Type: Surface Mounted Inductors
Typical Values: 0.01 μ H to 100 μ H
Applications: Found in many electronic circuits that require miniature components on multilayered PCB.



Type: Adjustable RF Coil
Typical Values: 1 μ H to 100 μ H
Applications: Variable inductor used in oscillators and various RF circuits such as CB transceivers, televisions, and radios.

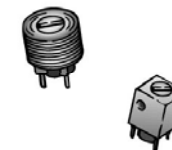

Indutores na prática



Projeto simplificado de indutores

Bobinas longas:

$$L = \frac{\mu \cdot N^2 \cdot A}{\ell} \longrightarrow \boxed{N = \sqrt{\frac{L \cdot \ell}{\mu \cdot A}}}$$

N - número de espiras da bobina indutora

L - Indutância da bobina indutora, [Henry, H];

A - área das espiras da bobina (área do núcleo), [metro quadrado, m²];

ℓ - comprimento longitudinal da bobina, [metro, m];

μ - permeabilidade magnética do meio no núcleo da bobina [Henry por metro, H/m];

Projeto simplificado de indutores

Bobina de camada única com núcleo de ar:

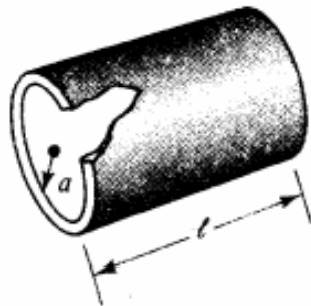

$$N = \sqrt{\frac{L \cdot (9 \cdot a + 10 \cdot \ell)}{39,5 \cdot a^2}}$$

N - número de espiras da bobina indutora;

L - indutância desejada para o indutor, [Micro Henry, μH];

ℓ - comprimento longitudinal da bobina [metro, m];

a - raio do núcleo (raio das espiras), [metro, m]

Projeto simplificado de indutores

Bobina de diversas camadas com núcleo de ar:

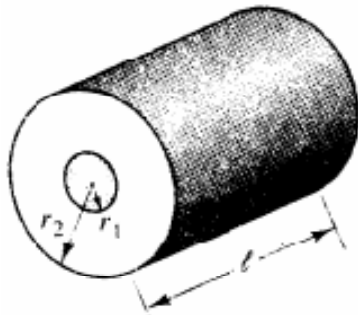

$$N = \sqrt{\frac{L \cdot (6r_1 + 9l + 10(r_2 - r_1))}{31,6 \cdot r_1^2}}$$

N - número de espiras da bobina indutora;

L - indutância desejada para o indutor, [Micro Henry, μH];

l - comprimento longitudinal da bobina, [metro, m];

r_1 - raio interno da bobina (raio das espiras interiores), [metro, m];

r_2 - raio externo da bobina (raio das espiras exteriores), [metro, m].

Projeto simplificado de indutores

Núcleos toroidais:

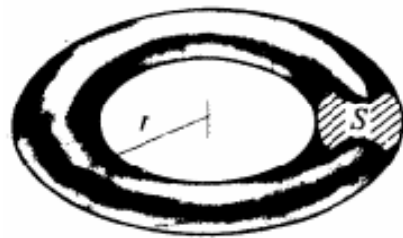

$$N = \sqrt{\frac{2 \cdot \pi \cdot r \cdot L}{\mu \cdot A}}$$

N - número de espiras da bobina indutora;

L - indutância desejada para o indutor, [Henry, H];

r - raio médio do toroide¹⁴, [metro, m];

μ - permeabilidade magnética do material do núcleo, [Henry por metro, H/m];

A - área da seção transversal do núcleo toroide (área das espiras da bobina), [metro quadrado, m²]

Projeto de um indutor

Tarefa:

- Indutância: $L = 100$ a $500 \mu\text{H}$;
- Núcleo de ar;
- Diâmetro: livre, conforme o carretel ou molde;
- Comprimento: livre;
- Número de camadas: livre;
- Corrente: $I = 1 \text{ A}$;
- Área do condutor: conforme tabela no Anexo B da apostila, para corrente especificada;
- Individual;
- Resposta deve conter todos os cálculos e considerações realizados.